

Rail-Mounted Terminal Blocks, TOPJOB® S

Front-Entry Wiring

		Page
	Through, Ground Conductor, Shield and Ex Terminal Blocks 0.14 mm ² to 16 (25 "f-st") mm ² (24-4 AWG)	2000 - 2016 Series 10
	Multilevel Rail-Mounted Terminal Blocks 1 (1.5) mm ² (16 AWG) and 2.5 (4) mm ² (12 AWG)	2000/2002 Series 24
	Disconnect/Test/Fuse Terminal Blocks and Through Terminal Blocks of Same Profile 0.25 mm ² to 2.5 (4) mm ² (22-12 AWG)	2002 Series 42
	Fuse Disconnect Terminal Blocks with Pivoting Fuse Holder 0.25 mm ² to 2.5 (4) mm ² (22-12 AWG)	2002 Series 50
	Disconnect, Ground Conductor Disconnect Terminal Blocks and Fuse Terminal Blocks 0.5 mm ² to 6 (10) mm ² (20-8 AWG)	2006 Series 60
	Disconnect/Test Terminal Blocks for Current and Voltage Transformer Circuits 0.5 mm ² to 6 (10) mm ² (20-8 AWG)	2007 Series 72
	Fuse Plugs on Carrier Terminal Blocks	2004/2006 Series 76
	Diode and LED Terminal Blocks 0.25 mm ² to 4 (6) mm ² (22-10 AWG)	2001/2002/2004 Series 80
	Multilevel Diode and LED Terminal Blocks 0.25 mm ² to 2.5 (4) mm ² (22-12 AWG)	2002 Series 86
	Diode, LED Modules and Empty Component Plug Housings	2002 Series 90
	Accessories for TOPJOB® S Rail-Mounted Terminal Blocks	
	- Banana Plugs	292
	- Marking Accessories	108
	- Various Jumpers	101
	- Step-Down Jumpers for Through Terminal Blocks	23
	- Connectors and Connector Strips	2001 - 2016 Series 96

CAGE CLAMP®S Rail-Mounted Terminal Blocks 2000 to 2016 Series

Simply push-in

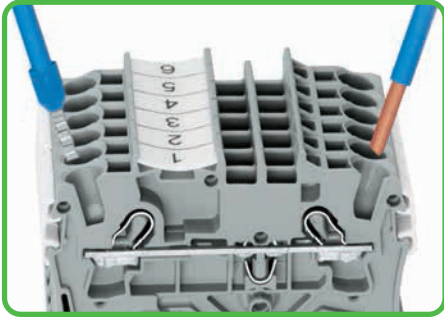

Directly insert solid and ferruled conductors.

Conductor termination

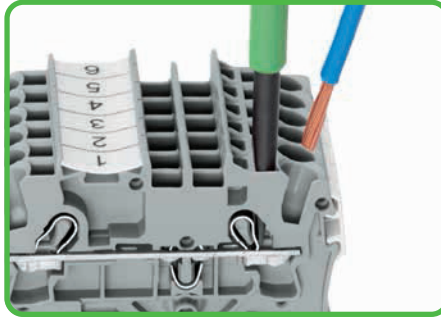

Terminating fine-stranded conductors using an operating tool.

Insulation stop

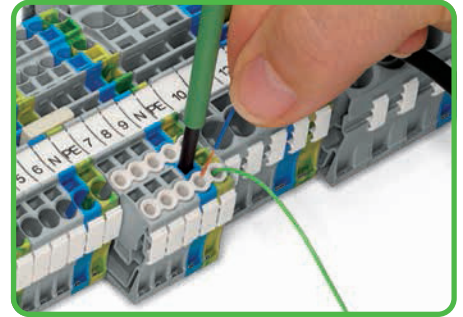

Conductor termination - Insulation stop.

Simply jumpered

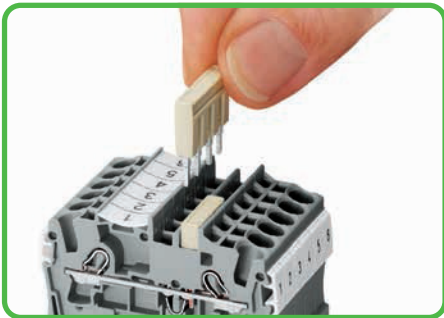

Insert push-in type jumper bar and push down firmly until it hits the backstop.

Customizable push-in type jumper bars



Breaking off jumper contacts (2000, 2001, 2002, 2004 Series)

Customizable push-in type jumper bars



Marking a customized push-in type jumper bar using a felt-tip pen.

CAGE CLAMP® S for all conductor types

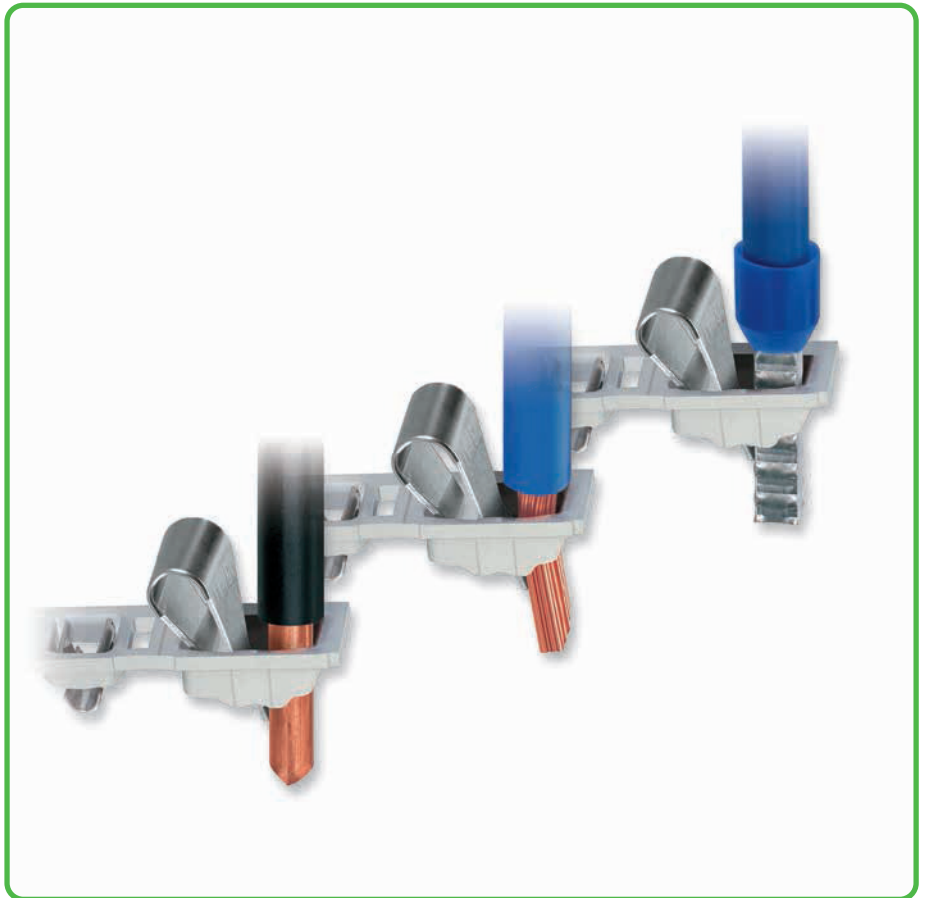

Step-down jumpers

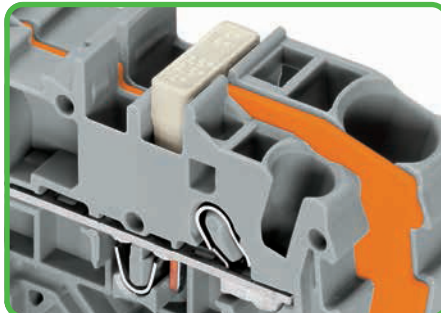

Commoning with step-down jumpers.

Star point jumpers

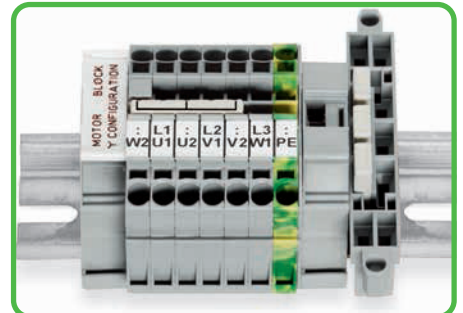

Star point jumpers designed for 'Y' configuration



CAGE CLAMP®S clamps the following copper conductors:*

solid



stranded



fine-stranded, also with tinned single strands

* For aluminum conductors, see notes in Section 14.

- Description and Handling -

Simply smaller

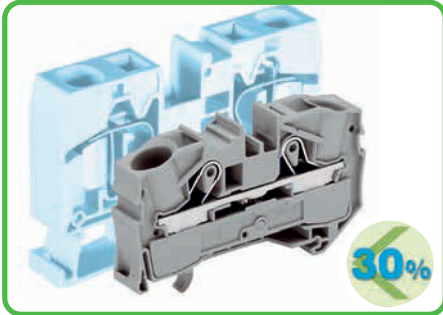

Up to 30% more compact. Advantage: More wiring space or smaller switch cabinets/junction boxes.

TOPJOB® S connectors

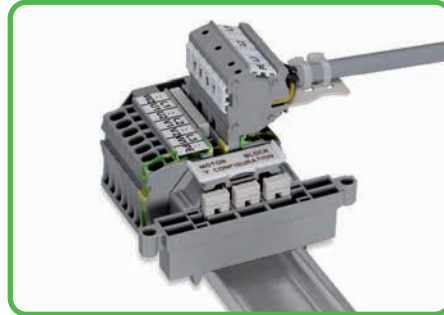

TOPJOB® S Connectors for the 2001 to 2016 Series can be easily inserted into jumper slots to provide an additional power tap.

Testing tap

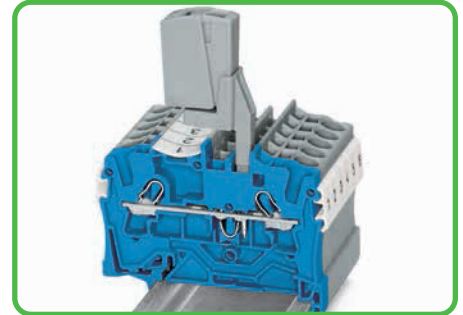

Testing tap suited for 2000 to 2016 Series terminal blocks. Tool-free connections for individual test wires up to 2.5 mm²/AWG 12.

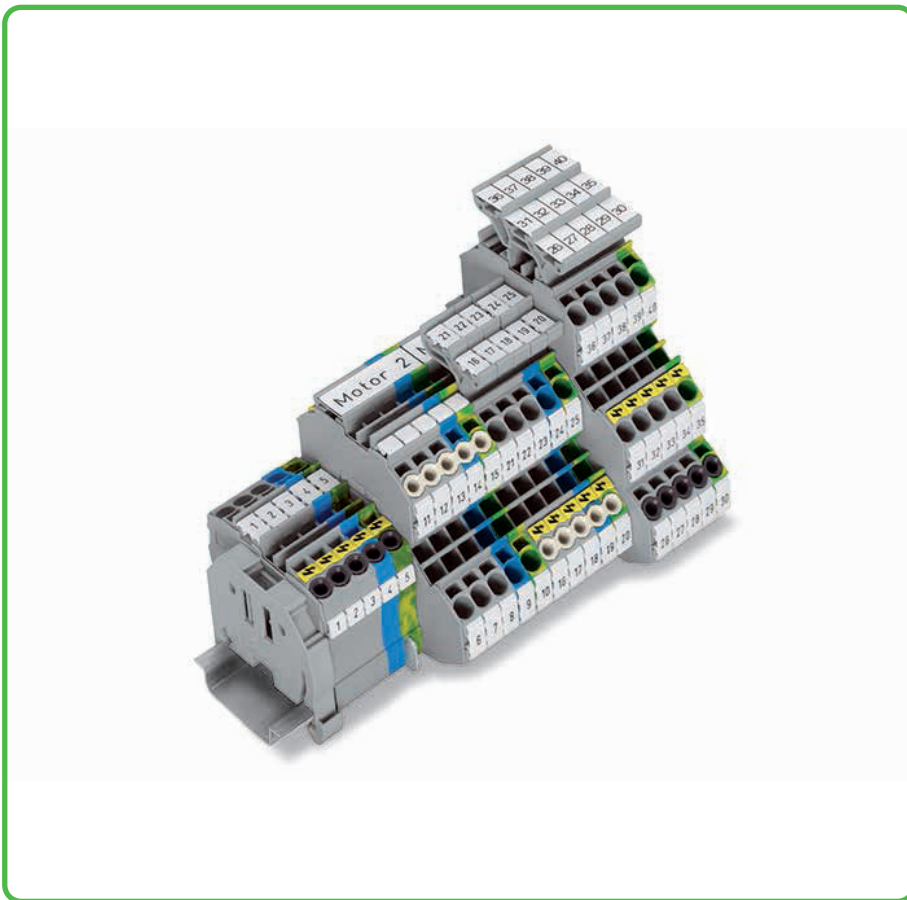

Test plug adapter



The test plug adapter for 4 mm Ø plugs is suited for 2000 to 2016 Series terminal blocks.

Simply marked

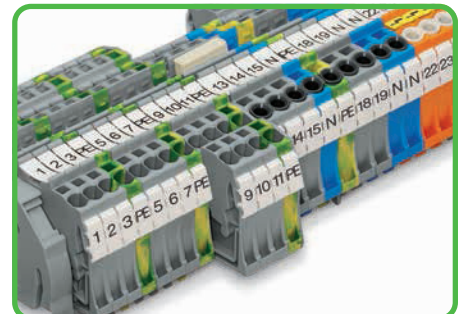

Marker strips for center marking

Wire jumpers

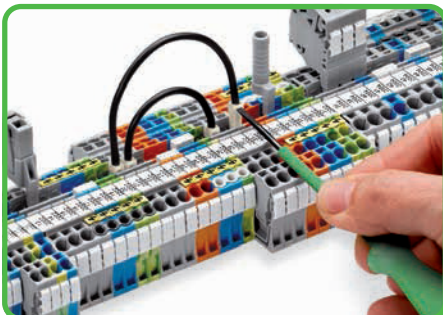

Push down the wire jumper until fully inserted. Lift the jumper with an operating tool for rewiring.

Marking

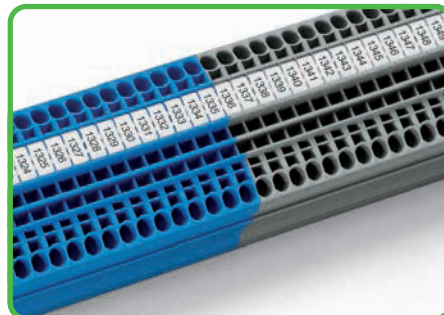

WMB Inline
WMB markers on roll

Marking

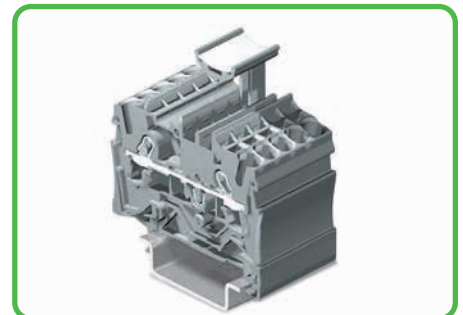

TOPJOB® S group marker carrier, snap-on type for jumper slot



fine-stranded,
tip-bonded



fine-stranded,
with ferrule
(gastight crimped)



fine-stranded,
with pin terminal
(gastight crimped)

- Simply Push-In - Conductor Termination/Removal Handling Ex e/Ex i Separators

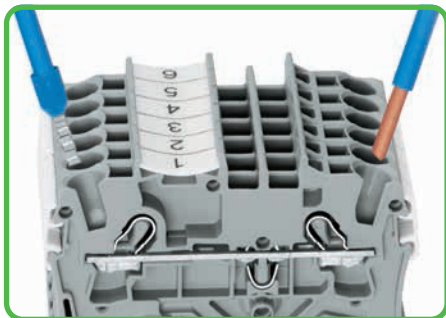

Tool-Free Terminations

Stripped solid, ferruled or ultrasonically "bonded" conductors are easily terminated by simply pushing them into a contact.

This advantage significantly reduces costs for conductors rated 0.5 mm² to 16 mm² (AWG 20-4) in applications such as electrical installations or factory wiring.

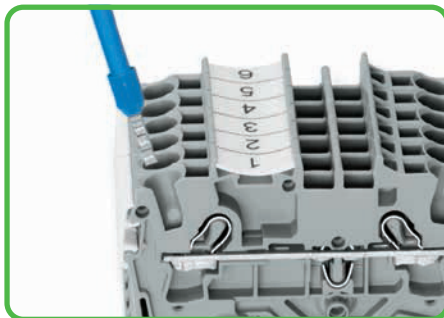

Stranded conductors with ferrules

from at least two sizes below the rated cross section up to the rated cross section can also be simply pushed in - without tools.

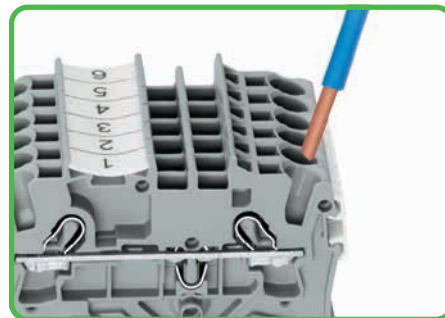

Conductor termination - Push-in connection

Solid conductors with cross sections from either one size above, or up to two sizes below, the rated cross section can be inserted directly - without tools.

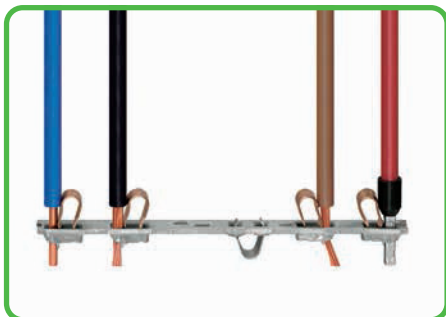

TOPJOB® S features universal CAGE CLAMP® S connection technology for all conductor types.



Conductor termination with operating tool

Connecting fine-stranded conductors without ferrules, or small cross-sectional conductors that cannot be pushed in, is performed similarly to the original CAGE CLAMP® - just use an operating tool.

The smart feature:

To open the clamp, the operating tool is inserted vertically. The conductor entry is less than 15 degrees resulting in easier wiring.

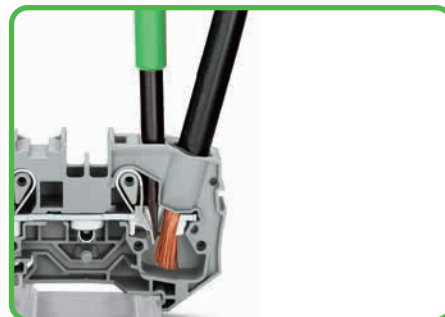

Conductor removal

Like the original CAGE CLAMP® an operating tool is used for conductor removal with CAGE CLAMP®S.

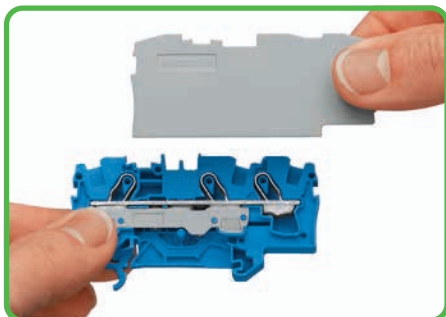

Separator for Ex e/Ex i applications

An end plate must be applied to the terminal block located directly behind an Ex e/Ex i separator plate.

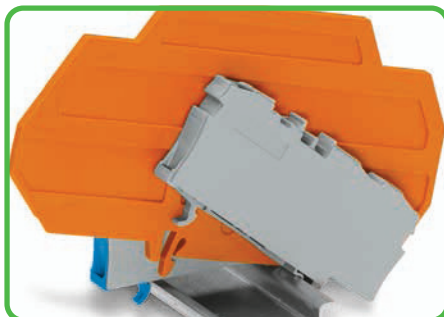

Ex e II/Ex i terminal strip

Notice:

The movable feet of terminal blocks and separator plates must face the same direction.

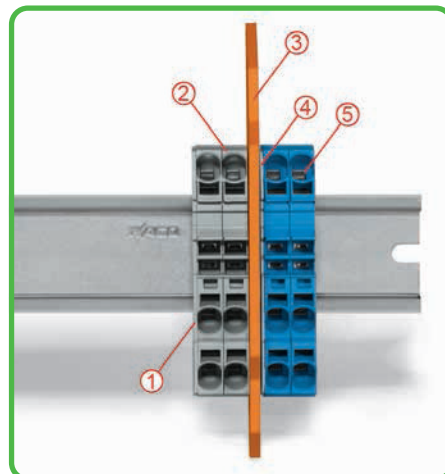

Separator located between Ex e II and Ex i terminal strip

- ① End plate
- ② Ex e II terminal blocks
- ③ Ex e/Ex i separator plate
- ④ End plate
- ⑤ Ex i terminal blocks

According to EN 50020, a minimum distance of 50 mm must be kept between live parts of Ex e and Ex i circuits. The use of Ex e/Ex i separators is a space-saving solution when Ex e and Ex i terminal blocks are mounted on a common carrier rail.

- Simply Jumpered - Handling Push-In Type Jumper Bars Angle-Type Rail-Mounted Terminal Blocks

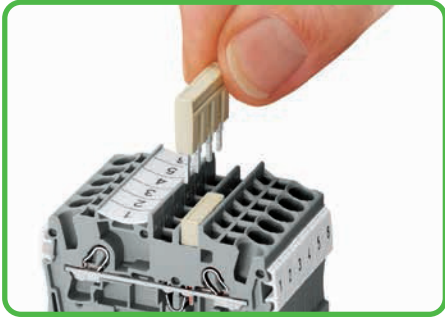

The push-in type jumper system is based on the common plug and socket principle. Each terminal block is spring-loaded with a double socket and a resilient CrNi steel spring. Therefore the jumpers, which consist of cathode copper, can be produced with particularly small dimensions. This does not impair their load carrying capacity in accordance with the terminal block rated current. Ground terminal blocks can also be commoned using the same jumper system. Custom jumpers are created by breaking and removing jumper contacts (2000, 2001, 2002, 2004 Series).

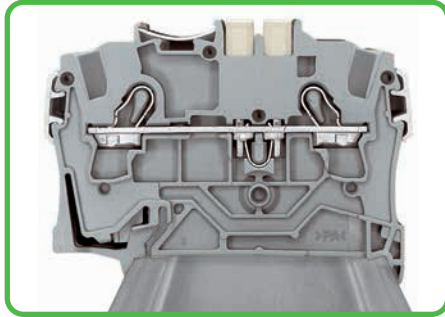



The smart feature:
Jumper slots can also be used for:

- push-in type jumper bars and step-down jumpers
- test plug adapters and testing taps
- preharnessed plugs for subassembly connections.

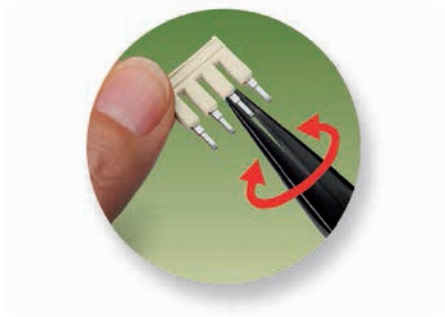

Push-in type jumper bars
800 V
600 V 
550 V 



Push-in type jumper bar
Breaking off jumper contacts (picture shows pin 3)
500 V
300 V 



Push-in type jumper bar
Marking a customized push-in type jumper bar using a felt-tip pen.

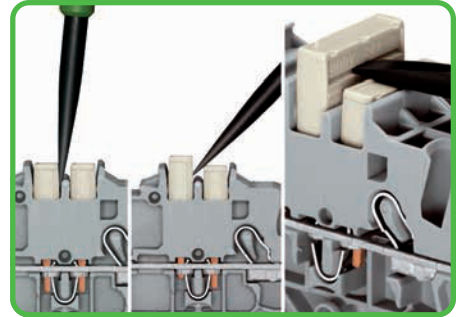

Removal of push-in type jumper bar
Insert the operating tool between the jumper and the partition wall of the dual jumper slots. Place the operating tool in the center of jumpers up to 5 contacts (see above), or alternately on both sides for jumpers with more than 5 contacts.

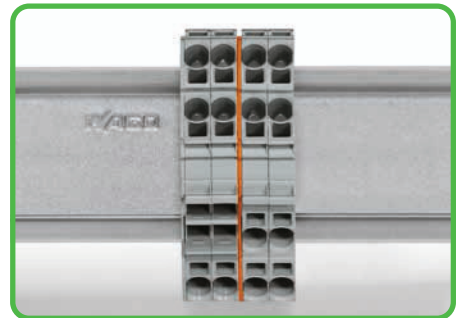
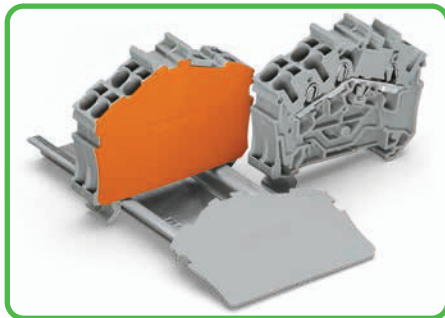

With continuous terminal strips an end plate must be used when changing from 3- to 4-conductor terminal blocks.

TOPJOB® S Through/Ground Conductor/Ex and Double-Potential Terminal Blocks 1 (1.5) mm², 2000 Series

0.14 - 1 (1.5) mm ² ① 800 V/8 kV/3 ② I _N 13.5 A (18 A) Terminal block width 3.5 mm / 0.138 in 9 - 11 mm / 0.39 in ③	AWG 24 - 16 600 V, 10 A ④ 600 V, 10 A ⑤	0.14 - 1 (1.5) mm ² ① 800 V/8 kV/3 ② I _N 13.5 A (18 A) Terminal block width 3.5 mm / 0.138 in 9 - 11 mm / 0.39 in ③	AWG 24 - 16 600 V, 10 A ④ 600 V, 10 A ⑤	0.14 - 1 (1.5) mm ² ① 800 V/8 kV/3 ② I _N 13.5 A (18 A) Terminal block width 3.5 mm / 0.138 in 9 - 11 mm / 0.39 in ③	AWG 24 - 16 600 V, 10 A ④ 600 V, 10 A ⑤
---	---	---	---	---	---

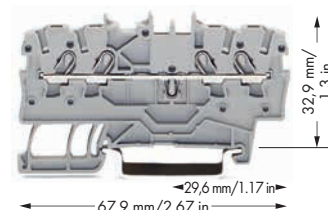
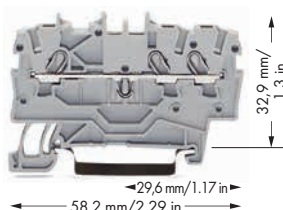
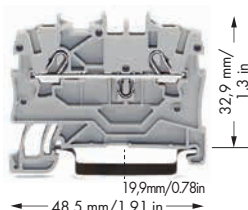

Item No.	Pack. Unit	Item No.	Pack. Unit	Item No.	Pack. Unit
2-conductor through terminal block		3-conductor through terminal block		4-conductor through terminal block	
gray ⑤	2000-1201 ⑤ 100	gray ⑤	2000-1301 ⑤ 100	gray ⑤	2000-1401 ⑤ 100
blue ⑤	2000-1204 ④ ⑤ 100	blue ⑤	2000-1304 ④ ⑤ 100	blue ⑤	2000-1404 ④ ⑤ 100
orange ⑤	2000-1202 ⑤ 100	orange ⑤	2000-1302 ⑤ 100	orange ⑤	2000-1402 ⑤ 100
red ⑤	2000-1203 ⑤ 100	red ⑤	2000-1303 ⑤ 100	red ⑤	2000-1403 ⑤ 100
black ⑤	2000-1205 ⑤ 100	black ⑤	2000-1305 ⑤ 100	black ⑤	2000-1405 ⑤ 100
yellow ⑤	2000-1206 ⑤ 100	yellow ⑤	2000-1306 ⑤ 100	yellow ⑤	2000-1406 ⑤ 100
2-conductor ground terminal block		3-conductor ground terminal block		4-conductor ground terminal block	
green-yellow ⑤	2000-1207 ⑤ 100	green-yellow ⑤	2000-1307 ⑤ 100	green-yellow ⑤	2000-1407 ⑤ 100
Item-Specific Accessories		Item-Specific Accessories		Item-Specific Accessories	
End and intermediate plate, 0.7 mm thick		End and intermediate plate, 0.7 mm thick		End and intermediate plate, 0.7 mm thick	
orange	2000-1292 100 (4x25)	orange	2000-1392 100 (4x25)	orange	2000-1492 100 (4x25)
gray	2000-1291 100 (4x25)	gray	2000-1391 100 (4x25)	gray	2000-1491 100 (4x25)
Ex e/Ex i separator, orange, 3 mm thick		Ex e/Ex i separator, orange, 3 mm thick		Ex e/Ex i separator, orange, 3 mm thick	
90 mm	209-190 50 (2x25)	120 mm	209-191 50 (2x25)	120 mm	209-191 50 (2x25)

2000 Series Accessories

Appropriate marking systems: WMB/Marking strips
(see Section 13)

Push-in type jumper bar, insulated, ⑥ I _N 14 A, light gray 2-way 2000-402 200 (8x25) 3-way 2000-403 200 (8x25) 4-way 2000-404 200 (8x25) 5-way 2000-405 100 (4x25) 6-way 2000-406 100 (4x25) 7-way 2000-407 100 (4x25) 8-way 2000-408 100 (4x25) 9-way 2000-409 100 (4x25) 10-way 2000-410 100 (4x25)	Protective warning marker, with high-voltage symbol, black, for 5 terminal blocks yellow 2000-115 100 (4x25) Delta jumper, insulated, ⑥ I _N = I _N terminal block, light gray 1-2 3-4 5-6 2000-406/020-000 100 (4x25) Star point jumper, insulated, ⑥ I _N = I _N terminal block, light gray 1-3-5 2000-405/011-000 100 (4x25)	Banana plug, for socket 4 mm Ø, color mixed 215-111 50 Testing tap, for max. 2.5 mm ² gray 2009-182 100 (4x25) Test plug, with 500 mm cable, 2 mm Ø red 210-136 50
Push-in type jumper bar, insulated, I _N 14 A, light gray from 1 to 3 2000-433 200 (8x25) from 1 to 4 2000-434 200 (8x25) from 1 to 5 2000-435 100 (4x25) from 1 to 6 2000-436 100 (4x25) from 1 to 7 2000-437 100 (4x25) from 1 to 8 2000-438 100 (4x25) from 1 to 9 2000-439 100 (4x25) from 1 to 10 2000-440 100 (4x25)	Push-in type wire jumper, ⑥ insulated, I _N 16 A, wire size 1.5 mm ² L = 60 mm 2009-402 100 (10x10) L = 110 mm 2009-404 100 (10x10) L = 250 mm 2009-406 100 (10x10) Test plug adapter, for 4 mm Ø test plug gray 2009-174 100 (4x25)	Test plug, with 500 mm cable, 2.3 mm Ø yellow 210-137 50 Marking strip, plain, 11 mm wide, 50 m roll white 2009-110 1 WMB Multi marking system, 10 strips with 10 markers per card, for 3.5 mm terminal block width plain 793-3501 5

0.14 - 1 (1.5) mm² ❶ | AWG 24 - 16
 800 V/8 kV/3 ❷
 I_N 13.5 A (18 A)
 Terminal block width 3.5 mm / 0.138 in
 9 - 11 mm / 0.39 in ❸

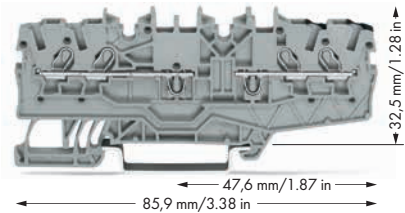

- ❶ Conductor sizes: 0.14 mm² - 1.5 mm² "s + f-st"; Push-in conductor sizes: 0.5 mm² - 1.5 mm² "s" and 0.5 mm² - 0.75 mm² "insulated ferrule, 10 mm"
- ❷ 800 V = rated voltage
8 kV = rated surge voltage
3 = pollution degree
(see Section 14)
- ❸ Strip length, see packaging or instructions.
- ❹ Suitable for Ex i applications
- ❺ Suitable for Ex e II applications
550 V, 13 A
Jumper 12 A
(see Section 14)
- ❻ See application notes for:
Ex e/Ex i separator plate, page 19
Colored push-in type jumper bars, page 101
Star point jumper, page 103
Delta jumper, page 103
Push-in type wire jumper, page 102

Item No.	Pack. Unit
Double-potential terminal block, both potentials can be commoned	
● gray 2000-2141	50

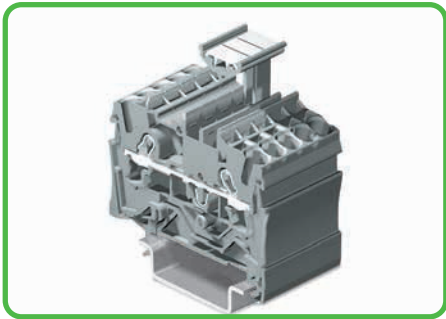

TOPJOB® S group marker carrier
 equipped with WMB Multi marking system.
 Suitable for all 2000 to 2016 Series TOPJOB® S rail-mount terminal blocks
 Do not use on an end plate!

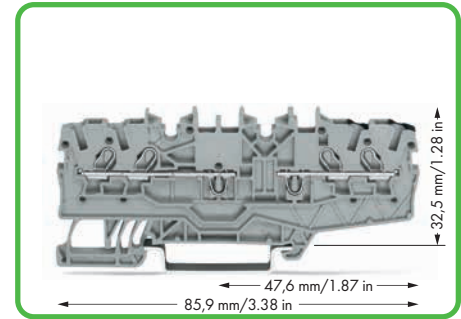

Double-potential terminal blocks are space savers. Two independent feedthrough circuits are placed in one insulated housing on one level in just 3.5 mm. This achieves a width of just 1.75 mm/0.069 in versus standard through terminal blocks. Input and output contacts of one circuit are placed on the same side of the terminal block. Both circuits can be individually marked according to input and output.

Item-Specific Accessories

End and intermediate plate, 0.7 mm thick		
orange	2000-2196	100 (4x25)
gray	2000-2195	100 (4x25)

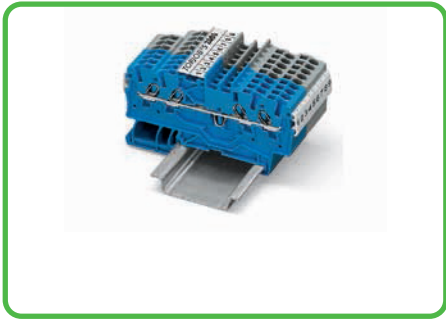

Standard and quick marking options:
 Three marker slots are available for both individual markers and marking strips.

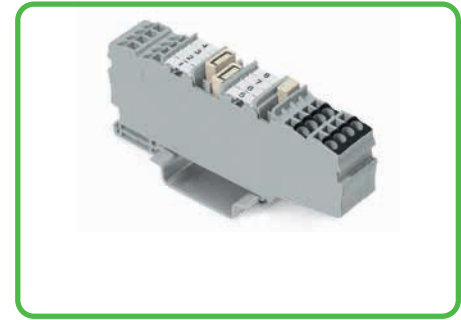

Standard and fast marking options:
 Four marker slots (double-potential terminal blocks) are available for both individual markers and marking strips

TOPJOB® S Through/Ground Conductor/Shield and Ex Terminal Blocks 1.5 (2.5) mm² 2001 Series

0.25 - 1.5 (2.5) mm ² ① 800 V/8 kV/3 ② I _N 18 A (24 A) Terminal block width 4.2 mm / 0.165 in 9 - 11 mm / 0.39 in ③	AWG 22 - 14 600 V, 15 A ④ 600 V, 15 A ⑤	0.25 - 1.5 (2.5) mm ² ① 800 V/8 kV/3 ② I _N 18 A (24 A) Terminal block width 4.2 mm / 0.165 in 9 - 11 mm / 0.39 in ③	AWG 22 - 14 600 V, 15 A ④ 600 V, 15 A ⑤	0.25 - 1.5 (2.5) mm ² ① 800 V/8 kV/3 ② I _N 18 A (24 A) Terminal block width 4.2 mm / 0.165 in 9 - 11 mm / 0.39 in ③	AWG 22 - 14 600 V, 15 A ④ 600 V, 15 A ⑤
---	---	---	---	---	---

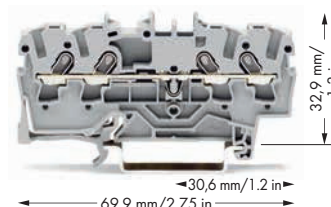
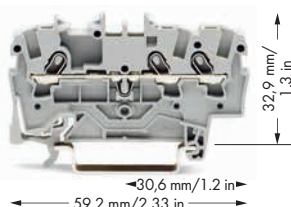
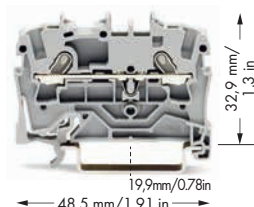

Item No.	Pack. Unit	Item No.	Pack. Unit	Item No.	Pack. Unit
2-conductor through terminal block		3-conductor through terminal block		4-conductor through terminal block	
gray ⑤ 2001-1201 ⑤ 100		gray ⑤ 2001-1301 ⑤ 100		gray ⑤ 2001-1401 ⑤ 100	
blue ⑤ 2001-1204 ④ ⑤ 100		blue ⑤ 2001-1304 ④ ⑤ 100		blue ⑤ 2001-1404 ④ ⑤ 100	
orange ⑤ 2001-1202 ⑤ 100		orange ⑤ 2001-1302 ⑤ 100		orange ⑤ 2001-1402 ⑤ 100	
red ⑤ 2001-1203 ⑤ 100		red ⑤ 2001-1303 ⑤ 100		red ⑤ 2001-1403 ⑤ 100	
black ⑤ 2001-1205 ⑤ 100		black ⑤ 2001-1305 ⑤ 100		black ⑤ 2001-1405 ⑤ 100	
yellow ⑤ 2001-1206 ⑤ 100		yellow ⑤ 2001-1306 ⑤ 100		yellow ⑤ 2001-1406 ⑤ 100	
2-conductor ground terminal block		3-conductor ground terminal block		4-conductor ground terminal block	
green-yellow ⑤ 2001-1207 ⑤ 100		green-yellow ⑤ 2001-1307 ⑤ 100		green-yellow ⑤ 2001-1407 ⑤ 100	
Other terminal blocks with the same profile:		Other terminal blocks with the same profile:		Other terminal blocks with the same profile:	
Diode 2001-1211/1000-411 Page 80		Diode 2001-1311/1000-411 Page 80		Diode 2001-1411/1000-411 Page 80	
		LED 2001-1321/1000-434 Page 80		LED 2001-1421/1000-434 Page 80	
				Double-potential 2001-1441 Page 13	

Item-Specific Accessories	Item-Specific Accessories	Item-Specific Accessories
End and intermediate plate, 0.8 mm thick	End and intermediate plate, 0.8 mm thick	End and intermediate plate, 0.8 mm thick
orange 2002-1292 100 (4x25)	orange 2002-1392 100 (4x25)	orange 2002-1492 100 (4x25)
gray 2002-1291 100 (4x25)	gray 2002-1391 100 (4x25)	gray 2002-1491 100 (4x25)
Separator, oversized, 2 mm thick	Separator, oversized, 2 mm thick	Separator, oversized, 2 mm thick
orange 2002-1294 100 (4x25)	orange 2002-1394 100 (4x25)	orange 2002-1494 100 (4x25)
gray 2002-1293 100 (4x25)	gray 2002-1393 100 (4x25)	gray 2002-1493 100 (4x25)
Ex e/Ex i separator, orange, 3 mm thick	Ex e/Ex i separator, orange, 3 mm thick	Ex e/Ex i separator, orange, 3 mm thick
90 mm 209-190 50 (2x25)	120 mm 209-191 50 (2x25)	120 mm 209-191 50 (2x25)

2001 Series Accessories

Appropriate marking systems: WMB/WMB Inline/Marking strips
(see Section 13)

Insulation stop,	Push-in type jumper bar, insulated,	Push-in type jumper bar, insulated,
5 pcs/strip, 0.25 - 0.5 mm ² light gray 2001-171 200 (8x25)	I _N 18 A, light gray 2-way 2001-402 200 (8x25)	I _N 18 A, light gray from 1 to 3 2001-433 200 (8x25)
Step-down jumper, insulated, I _N 32 A light gray 2006-499 50 (2x25)	3-way 2001-403 200 (8x25)	from 1 to 4 2001-434 200 (8x25)
	4-way 2001-404 200 (8x25)	from 1 to 5 2001-435 100 (4x25)
	5-way 2001-405 100 (4x25)	from 1 to 6 2001-436 100 (4x25)
	6-way 2001-406 100 (4x25)	from 1 to 7 2001-437 100 (4x25)
	7-way 2001-407 100 (4x25)	from 1 to 8 2001-438 100 (4x25)
	8-way 2001-408 100 (4x25)	from 1 to 9 2001-439 100 (4x25)
	9-way 2001-409 100 (4x25)	from 1 to 10 2001-440 100 (4x25)
Protective warning marker, with high-voltage symbol, black, for 5 terminal blocks yellow 2001-115 100 (4x25)	10-way 2001-410 100 (4x25)	

Double-Potential Terminal Blocks 1.5 (2.5) mm² 2001 Series

- ① Conductor sizes: 0.25 mm² - 2.5 mm² "s + f-st";
Push-in conductor sizes: 0.5 mm² - 2.5 mm² "s"
and 0.75 mm² - 1.5 mm²
"insulated ferrule, 12 mm"
- ② 800 V = rated voltage
8 kV = rated surge voltage
3 = pollution degree
(see Section 14)
- ③ Strip length, see packaging or instructions.
- ④ Suitable for Ex i applications
- ⑤ Suitable for Ex e II applications
550 V, 17 A
Jumper 16 A
(see Section 14)
- ⑥ See application notes for:
Ex e/Ex i separator plate, page 19
Step-down jumper, page 23
Star point jumper, page 103
Delta jumper, page 103
Push-in type wire jumper, page 102
TOPJOB®S connector, page 96

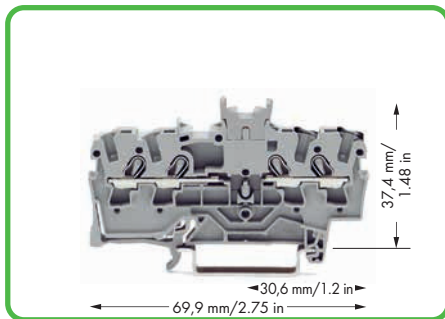

Double-potential terminal block with double marker slot centered on terminal block
gray 2001-1441
Packing unit: 100 pcs

















Notice: This double-potential terminal block cannot be commoned with push-in type jumper bars!

Double-potential terminal blocks are space savers. Two independent feedthrough circuits are placed in one insulated housing on one level in just 4.2 mm. This achieves a width of just 2.1 mm/0.083 in versus standard through terminal blocks. Input and output contacts of one circuit are placed on the same side of the terminal block. Both circuits can be individually marked according to input and output.

For technical data and accessories, see www.wagocatalog.com

2001 Series Accessories

Appropriate marking systems: WMB/WMB Inline/Marking strips
(see Section 13)

Delta jumper, insulated,  I _N = I _N terminal block, light gray 1-2 3-4 5-6 2001-406/020-000 100 (4x25)	WMB Inline, plain,  stretchable 4 - 4.2 mm, 2,000 WMB markers, 4 mm, on roll white 2009-114 1
Star point jumper, insulated,  I _N = I _N terminal block, light gray 1-3-5 2001-405/011-000 100 (4x25)	WMB Multi marking system,  10 strips with 10 markers per card, stretchable 4 - 4.2 mm plain 793-4501 5
Push-in type wire jumper,  insulated, I _N 16 A, wire size 1.5 mm ² L = 60 mm 2009-412 100 (10x10) L = 110 mm 2009-414 100 (10x10) L = 250 mm 2009-416 100 (10x10)	WMB Multi marking system, plain,  10 strips with 10 markers per card, stretchable 4 - 4.2 mm yellow 793-4501/000-002 red 793-4501/000-005 blue 793-4501/000-006 gray 793-4501/000-007 orange 793-4501/000-012 light green 793-4501/000-017 green 793-4501/000-023 violet 793-4501/000-024 5
Modular TOPJOB®S connector,  can be snapped together, for jumper contact slot gray 2001-511 100 (4x25)	Marking strip, plain,  11 mm wide, 50 m roll white 2009-110 1
Spacer module, can be snapped together,  e.g., for bridging commoned terminal blocks gray 2001-549 100 (4x25)	Screwless end stop,  for DIN 35 rail, 6 mm wide gray 249-116 100 (4x25)
End plate,  for modular TOPJOB®S connectors, 1.5 mm thick gray 2002-541 100 (4x25)	Screwless end stop,  for DIN 35 rail, 10 mm wide gray 249-117 50 (2x25)
Test plug adapter,  for 4 mm Ø test plug gray 2009-174 100 (4x25)	
Banana plug,  for socket 4 mm Ø, color mixed 215-111 50	
Testing tap,  for max. 2.5 mm ² gray 2009-182 100 (4x25)	
Test plug,  with 500 mm cable, 2 mm Ø red 210-136 50	
Test plug,  with 500 mm cable, 2.3 mm Ø yellow 210-137 50	

TOPJOB® S

Through/Ground Conductor/Shield and Ex Terminal Blocks 2.5 (4) mm²

2002 Series

<p>0.25 - 2.5 (4) mm² ① AWG 22 - 12 800 V/8 kV/3 ② I_N 24 A (32 A)</p> <p>Terminal block width 5.2 mm / 0.205 in 10 - 12 mm / 0.43 in ③</p>	<p>0.25 - 2.5 (4) mm² ① AWG 22 - 12 800 V/8 kV/3 ② I_N 24 A (32 A)</p> <p>Terminal block width 5.2 mm / 0.205 in 10 - 12 mm / 0.43 in ③</p>	<p>0.25 - 2.5 (4) mm² ① AWG 22 - 12 800 V/8 kV/3 ② I_N 24 A (32 A)</p> <p>Terminal block width 5.2 mm / 0.205 in 10 - 12 mm / 0.43 in ③</p>
--	--	--

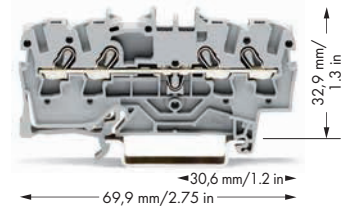
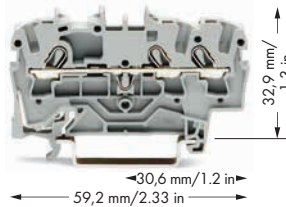
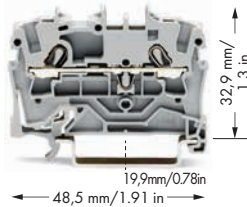

Item No.	Pack. Unit	Item No.	Pack. Unit	Item No.	Pack. Unit
2-conductor through terminal block		3-conductor through terminal block		4-conductor through terminal block	
gray ⑤ 2002-1201 ⑤	100	gray ⑤ 2002-1301 ⑤	100	gray ⑤ 2002-1401 ⑤	100
blue ⑤ 2002-1204 ④ ⑤	100	blue ⑤ 2002-1304 ④ ⑤	100	blue ⑤ 2002-1404 ④ ⑤	100
orange ⑤ 2002-1202 ⑤	100	orange ⑤ 2002-1302 ⑤	100	orange ⑤ 2002-1402 ⑤	100
red ⑤ 2002-1203 ⑤	100	red ⑤ 2002-1303 ⑤	100	red ⑤ 2002-1403 ⑤	100
black ⑤ 2002-1205 ⑤	100	black ⑤ 2002-1305 ⑤	100	black ⑤ 2002-1405 ⑤	100
yellow ⑤ 2002-1206 ⑤	100	yellow ⑤ 2002-1306 ⑤	100	yellow ⑤ 2002-1406 ⑤	100
2-conductor ground terminal block		3-conductor ground terminal block		4-conductor ground terminal block	
green-yellow ⑤ 2002-1207 ⑤	100	green-yellow ⑤ 2002-1307 ⑤	100	green-yellow ⑤ 2002-1407 ⑤	100
		3-conductor shield terminal block		4-conductor shield terminal block	
		white 2002-1308	100	white 2002-1408	100
Other terminal blocks with the same profile:		Other terminal blocks with the same profile:		Other terminal blocks with the same profile:	
Diode 2002-1211/1000-411	Page 82	Diode 2002-1311/1000-411	Page 82	Diode 2002-1411/1000-411	Page 82
		LED 2002-1321/1000-434	Page 82	LED 2002-1421/1000-434	Page 82
				Double-potential 2002-1441	Page 15
Item-Specific Accessories		Item-Specific Accessories		Item-Specific Accessories	
End and intermediate plate, 0.8 mm thick		End and intermediate plate, 0.8 mm thick		End and intermediate plate, 0.8 mm thick	
orange 2002-1292	100 (4x25)	orange 2002-1392	100 (4x25)	orange 2002-1492	100 (4x25)
gray 2002-1291	100 (4x25)	gray 2002-1391	100 (4x25)	gray 2002-1491	100 (4x25)
Separator, oversized, 2 mm thick		Separator, oversized, 2 mm thick		Separator, oversized, 2 mm thick	
orange 2002-1294	100 (4x25)	orange 2002-1394	100 (4x25)	orange 2002-1494	100 (4x25)
gray 2002-1293	100 (4x25)	gray 2002-1393	100 (4x25)	gray 2002-1493	100 (4x25)
Ex e/Ex i separator, orange, 3 mm thick		Ex e/Ex i separator, orange, 3 mm thick		Ex e/Ex i separator, orange, 3 mm thick	
90 mm 209-190	50 (2x25)	120 mm 209-191	50 (2x25)	120 mm 209-191	50 (2x25)

2002 Series Accessories

Appropriate marking systems: WMB/Marking strips/WMB Inline (see Section 13)

Insulation stop,	Push-in type jumper bar, insulated,	Push-in type jumper bar, insulated,
5 pcs/strip, 0.25 - 0.5 mm ² light gray 2002-171 200 (8x25)	⑥ I _N 25 A, light gray 2-way 2002-402 200 (8x25) 3-way 2002-403 200 (8x25) 4-way 2002-404 200 (8x25) 5-way 2002-405 100 (4x25) 6-way 2002-406 100 (4x25) 7-way 2002-407 100 (4x25) 8-way 2002-408 100 (4x25) 9-way 2002-409 100 (4x25) 10-way 2002-410 100 (4x25)	I _N 25 A, light gray from 1 to 3 2002-433 200 (8x25) from 1 to 4 2002-434 200 (8x25) from 1 to 5 2002-435 100 (4x25) from 1 to 6 2002-436 100 (4x25) from 1 to 7 2002-437 100 (4x25) from 1 to 8 2002-438 100 (4x25) from 1 to 9 2002-439 100 (4x25) from 1 to 10 2002-440 100 (4x25)
Insulation stop, 5 pcs/strip, 0.75 - 1 mm ² dark gray 2002-172 200 (8x25)		
Protective warning marker, with high-voltage symbol, black, for 5 terminal blocks yellow 2002-115 100 (4x25)		

Double-Potential Terminal Blocks 2.5 (4) mm² 2002 Series Accessories for Rail-Mounted Terminal Blocks

CAGE CLAMP® S

1

15

1

- ① Conductor sizes: 0.25 mm² - 4 mm² "s + f-st";
Push-in conductor sizes: 0.75 mm² - 4 mm² "s"
and 0.75 mm² - 2.5 mm²
"insulated ferrule, 1.2 mm"
- ② 800 V = rated voltage
8 kV = rated surge voltage
3 = pollution degree
(see Section 14)
- ③ Strip length, see packaging or instructions.
- ④ Suitable for Ex i applications
- ⑤ Suitable for Ex e II applications
550 V, 22 A
Jumper 20 A
(see Section 14)
- ⑥ See application notes for:
Ex e/Ex i separator plate, page 19
Colored push-in type jumper bars, page 101
Staggered jumper, page 104
Delta jumper, page 103
Star point jumper, page 103
Step-down jumper, page 23
Adjacent jumper for continuous commoning,
page 101
Push-in type wire jumper, page 102
TOPJOB®S connector, page 96
TOPJOB®S L-type test plug module, page 100
Marker carrier, page 109

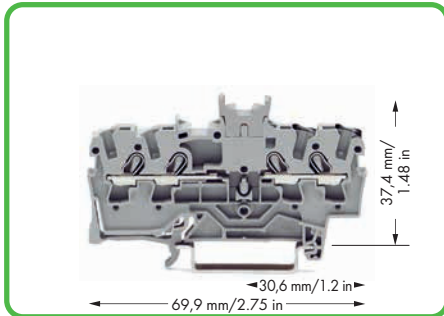

Double-potential terminal block with double marker slot centered on terminal block
gray 2002-1441
Packing unit: 100 pcs



















Notice: This double-potential terminal block cannot be commoned with push-in type jumper bars!

Double-potential terminal blocks are space savers. Two independent feedthrough circuits are placed in one insulated housing on one level in just 5.2 mm. This achieves a width of just 2.6 mm/0.103 in versus standard through terminal blocks. Input and output contacts of one circuit are placed on the same side of the terminal block. Both circuits can be individually marked according to input and output.

For technical data and accessories, see www.wagocatalog.com

2002 Series Accessories

Appropriate marking systems: WMB/Marking strips/WMB Inline
(see Section 13)

Staggered jumper,  insulated, I_N 25 A, light gray 2-way 2002-472 100 (4x25) 3-way 2002-473 100 (4x25) 4-way 2002-474 100 (4x25) 5-way 2002-475 50 (2x25) 6-way 2002-476 50 (2x25) 7-way 2002-477 50 (2x25) 8-way 2002-478 50 (2x25) 9-way 2002-479 50 (2x25) 10-way 2002-480 50 (2x25) 11-way 2002-481 50 (2x25) 12-way 2002-482 50 (2x25)	Push-in type wire jumper,  insulated, I_N 18 A, wire size 1.5 mm ² L = 60 mm 2009-412 100 (10x10) L = 110 mm 2009-414 100 (10x10) L = 250 mm 2009-416 100 (10x10)
Customized staggered jumper,  insulated, I_N 25 A, light gray 1-3 2002-473/011-000 100 (4x25) 1-3-5 2002-475/011-000 100 (4x25) 1-3-5-7 2002-477/011-000 100 (4x25) 1-3-5-7-9 2002-479/011-000 100 (4x25) 1-3-5-7-9-11 2002-481/011-000 50 (2x25)	Modular TOPJOB®S connector,  can be snapped together, for jumper contact slot gray 2002-511 100 (4x25)
Delta jumper, insulated,  $I_N = I_N$ terminal block, light gray 1-2 3-4 5-6 2002-406/020-000 100 (4x25)	Spacer module, can be snapped together, e.g., for bridging commoned terminal blocks  gray 2002-549 100 (4x25)
Star point jumper, insulated,  $I_N = I_N$ terminal block, light gray 1-3-5 2002-405/011-000 100 (4x25)	End plate,  for modular TOPJOB®S connectors, 1.5 mm thick gray 2002-541 100 (4x25)
Step-down jumper, insulated,  I_N 32 A light gray 2006-499 50 (2x25)	Test plug adapter,  for 4 mm Ø test plug gray 2009-174 100 (4x25)
Adjacent jumper for continuous commoning, insulated,  I_N 25 A, light gray 2-way 2002-400 100 (4x25)	Testing tap,  for max. 2.5 mm ² gray 2009-182 100 (4x25)
WMB Inline, plain,  stretchable 5 - 5.2 mm, 1,500 WMB markers, 5 mm, on roll white 2009-115 1	TOPJOB®S L-test plug module,  can be snapped together gray 2002-611 100 (4x25)
	TOPJOB®S L-type spacer module, can be snapped together, e.g., for bridging commoned terminal blocks  gray 2002-649 100 (4x25)
	End plate, for modular TOPJOB®S test plugs,  1.5 mm thick gray 2002-641 100 (4x25)
	Marker carrier,  for jumper slots 2002 Series, 5 mm wide gray 2002-161 100 (4x25)
	WMB Multi marking system,  10 strips with 10 markers per card, stretchable 5 - 5.2 mm plain 793-5501 5



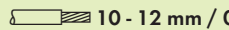

TOPJOB® S Through/Ground Conductor/Shield and Ex Terminal Blocks 2.5 (4) mm², 2002 Series

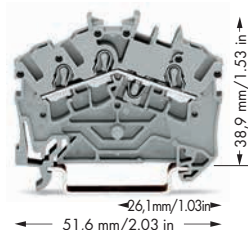

0.25 - 2.5 (4) mm² ① AWG 22 - 12
 800 V/8 kV/3 ② 600 V, 20 A ④
 I_N 24 A (32 A) 600 V, 20 A ④
 Terminal block width 5.2 mm / 0.205 in
 10 - 12 mm / 0.43 in ③



- ① Conductor sizes: 0.25 mm² - 4 mm² "s + f-st"; Push-in conductor sizes: 0.75 mm² - 4 mm² "s" and 0.75 mm² - 2.5 mm² "insulated ferrule, 12 mm"
- ② 800 V = rated voltage
8 kV = rated surge voltage
3 = pollution degree
(see Section 14)
- ③ Strip length, see packaging or instructions.
- ④ Suitable for Ex i applications
- ⑤ Suitable for Ex e II applications
550 V, 22 A
Jumper 20 A
(see Section 14)
- ⑥ See application notes for:
Ex e/Ex i separator plate, page 19
Colored push-in type jumper bars, page 101
Staggered jumper, page 104
Delta jumper, page 104
Star point jumper, page 101
Adjacent jumper for continuous commoning, page 101
Push-in type wire jumper, page 102
TOPJOB®S connector, page 96
TOPJOB®S L-type test plug module, page 100
Marker carrier, page 109

Item No.	Pack. Unit	2002 Series Accessories	
3-conductor through terminal block		Appropriate marking systems: WMB/Marking strips/WMB Inline (see Section 13)	
gray ⑤	2002-6301 ⑤ 100	Push-in type jumper bar, insulated, I _N 25 A, light gray 	Push-in type wire jumper, ⑥ insulated, I _N 18 A, wire size 1.5 mm ² 
blue ⑤	2002-6304 ④ ⑤ 100		
orange ⑤	2002-6302 ⑤ 100		
red ⑤	2002-6303 ⑤ 100		
black ⑤	2002-6305 ⑤ 100		
yellow ⑤	2002-6306 ⑤ 100		
3-conductor ground terminal block		from 1 to 3 2002-433 200 (8x25)	L = 60 mm 2009-412 100 (10x10)
green-yellow ⑤	2002-6307 ⑤ 100	from 1 to 4 2002-434 200 (8x25)	L = 110 mm 2009-414 100 (10x10)
3-conductor shield terminal block		from 1 to 5 2002-435 100 (4x25)	L = 250 mm 2009-416 100 (10x10)
white	2002-6308 100	from 1 to 6 2002-436 100 (4x25)	
2002 Series Accessories		from 1 to 7 2002-437 100 (4x25)	Protective warning marker, with high-voltage symbol, black, for 5 terminal blocks  yellow 2002-115 100 (4x25)
End and intermediate plate, 0.8 mm thick		from 1 to 8 2002-438 100 (4x25)	Modular TOPJOB®S connector, ⑥ can be snapped together, for jumper contact slot gray 2002-511 100 (4x25)
orange	2002-6392 100 (4x25)	Delta jumper, insulated, ⑥ I _N = I _N terminal block, light gray 1-2 3-4 5-6 2002-406/020-000 100 (4x25)	TOPJOB®S L-test plug module, ⑥ can be snapped together gray 2002-611 100 (4x25)
gray	2002-6391 100 (4x25)	Star point jumper, insulated, ⑥ I _N = I _N terminal block, light gray 1-3-5 2002-405/011-000 100 (4x25)	Test plug adapter, for 4 mm Ø test plug gray 2009-174 100 (4x25)
Ex e/Ex i separator, orange, 3 mm thick 		Staggered jumper, ⑥ insulated, I _N 25 A, light gray	Testing tap, for max. 2.5 mm ² gray 2009-182 100 (4x25)
Insulation stop, 5 pcs/strip, 0.25 - 0.5 mm ² light gray 2002-171 200 (8x25)		2-way 2002-472 100 (4x25)	WMB Inline, plain, stretchable 5 - 5.2 mm, 1,500 WMB markers, 5 mm, on roll white 2009-115 1
Insulation stop, 5 pcs/strip, 0.75 - 1 mm ² dark gray 2002-172 200 (8x25)		3-way 2002-473 100 (4x25)	WMB Multi marking system, 10 strips with 10 markers per card, stretchable 5 - 5.2 mm plain 793-5501 5
Push-in type jumper bar, insulated, ⑥ I _N 25 A, light gray		4-way 2002-474 100 (4x25)	Marking strip, plain, 11 mm wide, 50 m roll white 2009-110 1
2-way 2002-402 200 (8x25)		5-way 2002-475 50 (2x25)	TOPJOB®S group marker carrier, snap-on type for jumper slot, 5 mm wide gray 2009-191 50 (2x25)
3-way 2002-403 200 (8x25)		6-way 2002-476 50 (2x25)	Marker carrier, ⑥ for jumper slots 2002 Series, 5 mm wide gray 2002-161 100 (4x25)
4-way 2002-404 200 (8x25)		7-way 2002-477 50 (2x25)	
5-way 2002-405 100 (4x25)		8-way 2002-478 50 (2x25)	
6-way 2002-406 100 (4x25)		9-way 2002-479 50 (2x25)	
7-way 2002-407 100 (4x25)		10-way 2002-480 50 (2x25)	
8-way 2002-408 100 (4x25)		11-way 2002-481 50 (2x25)	
9-way 2002-409 100 (4x25)		12-way 2002-482 50 (2x25)	
10-way 2002-410 100 (4x25)		Customized staggered jumper, insulated, I _N 25 A, light gray	
Adjacent jumper for continuous commoning, insulated, ⑥ I _N 25 A, light gray		1-3 2002-473/011-000 100 (4x25)	
2-way 2002-400 100 (4x25)		1-3-5 2002-475/011-000 100 (4x25)	
		1-3-5-7 2002-477/011-000 100 (4x25)	
		1-3-5-7-9 2002-479/011-000 100 (4x25)	
		1-3-5-7-9-11 2002-481/011-000 50 (2x25)	

TOPJOB® S Through/Ground Conductor and Ex Terminal Blocks 2.5 (4) mm² 2002 Series

CAGE CLAMP® S

1
17
1

0.25 - 2.5 (4) mm ² ①	AWG 22 - 12
800 V/8 kV/3 ②	600 V, 20 A ④
I _N 24 A (32 A)	600 V, 20 A ④
Terminal block width 5.2 mm / 0.205 in	
10 - 12 mm / 0.43 in ③	

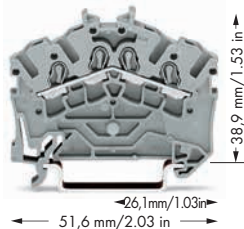

- Conductor sizes: 0.25 mm² - 4 mm² "s + f-st"; Push-in conductor sizes: 0.75 mm² - 4 mm² "s" and 0.75 mm² - 2.5 mm² "insulated ferrule, 12 mm"
- 800 V = rated voltage
8 kV = rated surge voltage
3 = pollution degree
(see Section 14)
- Strip length, see packaging or instructions.
- Suitable for Ex i applications
- Suitable for Ex e II applications
550 V, 22 A
Jumper 20 A
(see Section 14)
- See application notes for:
Ex e/Ex i separator plate, page 19

Item No.	Pack. Unit
4-conductor through terminal block	
gray ⑤	2002-6401 ⑤ 100
blue ⑤	2002-6404 ④ ⑤ 100
orange ⑤	2002-6402 ⑤ 100
red ⑤	2002-6403 ⑤ 100
black ⑤	2002-6405 ⑤ 100
yellow ⑤	2002-6406 ⑤ 100
4-conductor ground terminal block	
green-yellow ⑤	2002-6407 ⑤ 100
Notice: These terminal blocks cannot be commoned with push-in type jumper bars.	

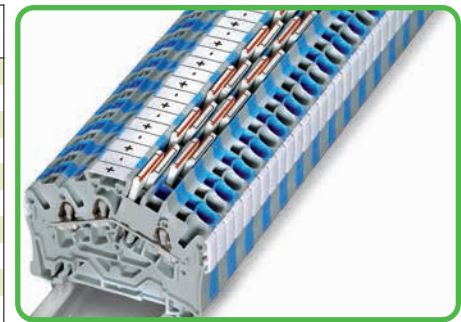

3- and 4-conductor terminal blocks of angled type
The TOPJOB®S rail-mounted terminal blocks have a 35-degree conductor entry angle permitting a very small bend radius and an extremely short wiring distance to the cable duct. For applications in switchgear and control cabinets using the LSC wiring system from Lütze, e.g., these terminal blocks are a space- and cost-saving solution. This allows the cable duct to be placed very close to the terminal blocks, keeping its height relatively low.

2002 Series Accessories

Appropriate marking systems: WMB/Marking strips/WMB Inline
(see Section 13)

End and intermediate plate, 0.8 mm thick	WMB Multi marking system,
orange 2002-6392 100 (4x25)	10 strips with 10 markers per card, stretchable 5 - 5.2 mm
gray 2002-6391 100 (4x25)	plain 793-5501 5
Ex e/Ex i separator, orange,	WMB Multi marking system, plain,
⑥ 3 mm thick	10 strips with 10 markers per card, stretchable 5 - 5.2 mm
120 mm 209-191 50 (2x25)	yellow 793-5501/000-002
Insulation stop,	red 793-5501/000-005
5 pcs/strip, 0.25 - 0.5 mm ²	blue 793-5501/000-006
light gray 2002-171 200 (8x25)	gray 793-5501/000-007
Insulation stop,	orange 793-5501/000-012
5 pcs/strip, 0.75 - 1 mm ²	light green 793-5501/000-017
dark gray 2002-172 200 (8x25)	green 793-5501/000-023
Protective warning marker,	violet 793-5501/000-024 5
with high-voltage symbol, black, for 5 terminal blocks	Screwless end stop,
yellow 2002-115 100 (4x25)	for DIN 35 rail, 6 mm wide
WMB Inline, plain,	gray 249-116 100 (4x25)
stretchable 5 - 5.2 mm, 1,500 WMB markers, 5 mm, on roll	Screwless end stop,
white 2009-115 1	for DIN 35 rail, 10 mm wide
Marking strip, plain,	gray 249-117 50 (2x25)
11 mm wide, 50 m roll	
white 2009-110 1	

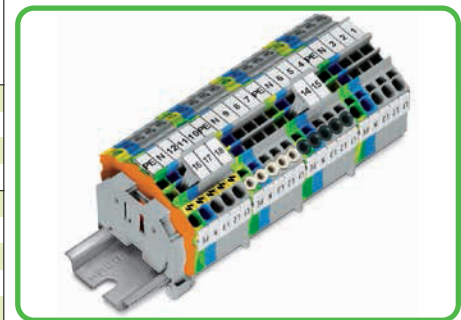

Product features:

- CAGE CLAMP®S connection for all conductor types, with the additional benefit of stripped solid wires and fine-stranded ferruled wires being simply pushed in
- Vibration-proof, fast, maintenance-free terminations
- 3-conductor through and ground conductor terminal blocks equipped with a dual jumper slot
- 4-conductor terminal blocks permit potential multiplication - no additional jumpers or terminal blocks needed
- 3- and 4-conductor terminal blocks have the same dimensions

An end plate must be applied when changing from a 3-conductor terminal block to a 4-conductor terminal block and vice versa.

TOPJOB® S Through/Ground Conductor/Shield and Ex Terminal Blocks 4 (6) mm² 2004 Series

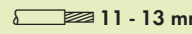
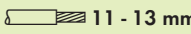

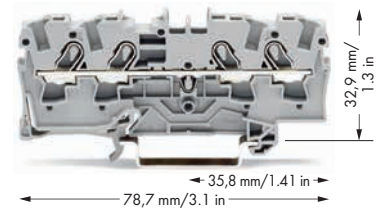
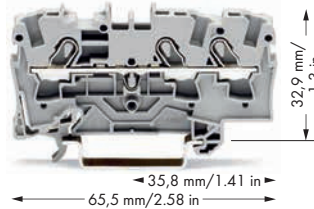
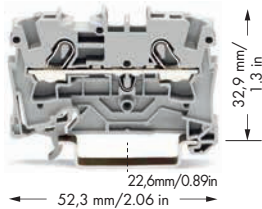





0.5 - 4 (6) mm² ① AWG 20 - 10 800 V/8 kV/3 ② 600 V, 30 A ⚡ I_N 32 A (41 A) 600 V, 30 A Ⓢ Terminal block width 6.2 mm / 0.244 in  11 - 13 mm / 0.47 in ③	0.5 - 4 (6) mm² ① AWG 20 - 10 800 V/8 kV/3 ② 600 V, 30 A ⚡ I_N 32 A (41 A) 600 V, 30 A Ⓢ Terminal block width 6.2 mm / 0.244 in  11 - 13 mm / 0.47 in ③	0.5 - 4 (6) mm² ① AWG 20 - 10 800 V/8 kV/3 ② 600 V, 30 A ⚡ I_N 32 A (41 A) 600 V, 30 A Ⓢ Terminal block width 6.2 mm / 0.244 in  11 - 13 mm / 0.47 in ③
--	---	---



Item No.	Pack. Unit	Item No.	Pack. Unit	Item No.	Pack. Unit
2-conductor through terminal block		3-conductor through terminal block		4-conductor through terminal block	
gray ⑤	2004-1201 ⑤ 50	gray ⑤	2004-1301 ⑤ 50	gray ⑤	2004-1401 ⑤ 50
blue ⑤	2004-1204 ④ ⑤ 50	blue ⑤	2004-1304 ④ ⑤ 50	blue ⑤	2004-1404 ④ ⑤ 50
orange ⑤	2004-1202 ⑤ 50	orange ⑤	2004-1302 ⑤ 50	orange ⑤	2004-1402 ⑤ 50
red ⑤	2004-1203 ⑤ 50	red ⑤	2004-1303 ⑤ 50	red ⑤	2004-1403 ⑤ 50
black ⑤	2004-1205 ⑤ 50	black ⑤	2004-1305 ⑤ 50	black ⑤	2004-1405 ⑤ 50
yellow ⑤	2004-1206 ⑤ 50	yellow ⑤	2004-1306 ⑤ 50	yellow ⑤	2004-1406 ⑤ 50
2-conductor ground terminal block		3-conductor ground terminal block		4-conductor ground terminal block	
green-yellow ⑤	2004-1207 ⑤ 50	green-yellow ⑤	2004-1307 ⑤ 50	green-yellow ⑤	2004-1407 ⑤ 50
Other terminal blocks with the same profile:		Other terminal blocks with the same profile:		Other terminal blocks with the same profile:	
Diode	2004-1211/1000-401 Page 84	Diode	2004-1311/1000-401 Page 84	Diode	2004-1411/1000-401 Page 84
Item-Specific Accessories		Item-Specific Accessories		Item-Specific Accessories	
End and intermediate plate, 1 mm thick		End and intermediate plate, 1 mm thick		End and intermediate plate, 1 mm thick	
orange	2004-1292 100 (4x25)	orange	2004-1392 100 (4x25)	orange	2004-1492 100 (4x25)
gray	2004-1291 100 (4x25)	gray	2004-1391 100 (4x25)	gray	2004-1491 100 (4x25)
Separator, oversized, 2 mm thick		Separator, oversized, 2 mm thick		Separator, oversized, 2 mm thick	
orange	2004-1294 100 (4x25)	orange	2004-1394 100 (4x25)	orange	2004-1494 100 (4x25)
gray	2004-1293 100 (4x25)	gray	2004-1393 100 (4x25)	gray	2004-1493 100 (4x25)
Ex e/Ex i separator, orange, 3 mm thick		Ex e/Ex i separator, orange, 3 mm thick		Ex e/Ex i separator, orange, 3 mm thick	
90 mm	209-190 50 (2x25)	120 mm	209-191 50 (2x25)	120 mm	209-191 50 (2x25)

2004 Series Accessories

Appropriate marking systems: WMB/Marking strips
(see Section 13)

Insulation stop,  5 pcs/strip, 0.25 - 0.5 mm ² light gray 2004-171 200 (8x25)	Insulation stop,  5 pcs/strip, 0.75 - 1 mm ² dark gray 2004-172 200 (8x25)	Delta jumper, insulated,  ⑥ I _N = I _N terminal block, light gray 1-2 3-4 5-6 2004-406/020-000 100 (4x25)
Push-in type jumper bar, insulated,  I _N 32 A, light gray 2-way 2004-402 200 (8x25) 3-way 2004-403 200 (8x25) 4-way 2004-404 100 (4x25) 5-way 2004-405 100 (4x25) 6-way 2004-406 100 (4x25) 7-way 2004-407 100 (4x25) 8-way 2004-408 100 (4x25) 9-way 2004-409 100 (4x25) 10-way 2004-410 100 (4x25)	Push-in type jumper bar, insulated,  I _N 32 A, light gray from 1 to 3 2004-433 200 (8x25) from 1 to 4 2004-434 200 (8x25) from 1 to 5 2004-435 100 (4x25) from 1 to 6 2004-436 100 (4x25) from 1 to 7 2004-437 100 (4x25) from 1 to 8 2004-438 100 (4x25) from 1 to 9 2004-439 100 (4x25) from 1 to 10 2004-440 100 (4x25)	Star point jumper, insulated,  ⑥ I _N = I _N terminal block, light gray 1-3-5 2004-405/011-000 100 (4x25)
		Step-down jumper, insulated,  ⑥ I _N 32 A light gray 2006-499 50 (2x25)
		Protective warning marker,  with high-voltage symbol, black, for 5 terminal blocks yellow 2004-115 100 (4x25)

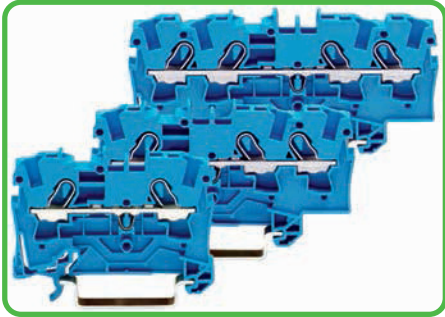

Through terminal blocks with blue insulated housing are suitable for Ex i applications.

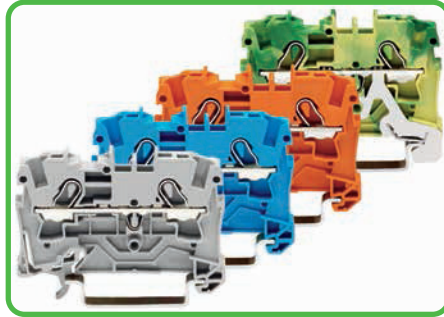

All through and ground conductor terminal blocks are suitable for Ex e II applications.

- 1 Conductor sizes: 0.5 mm² – 6 mm² "s + f-st";
Push-in conductor sizes: 1 mm² – 6 mm² "s"
and 0.75 mm² – 4 mm²
"insulated ferrule, 12 mm"
- 2 800 V = rated voltage
8 kV = rated surge voltage
3 = pollution degree
(see Section 14)
- 3 Strip length, see packaging or instructions.
- 4 Suitable for Ex i applications
- 5 Suitable for Ex e II applications
550 V, 30 A
(see Section 14)
- 6 See application notes for:
Step-down jumper, page 23
Star point jumper, page 103
Delta jumper, page 103
TOPJOB®S connector, page 134

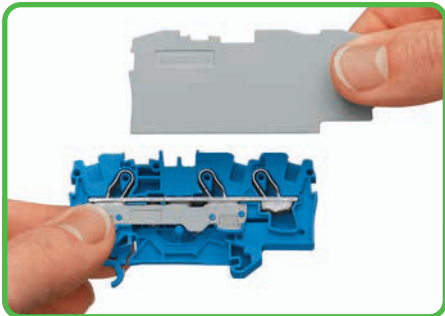

Separator for Ex e/Ex i applications

An end plate must be applied to the terminal block located directly behind an Ex e/Ex i separator plate.

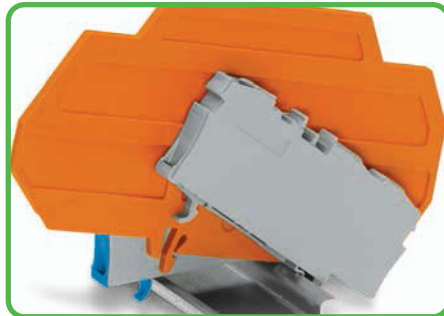

Ex e II/Ex i terminal strip

Notice:

The movable feet of terminal blocks and separator plate must face the same direction.

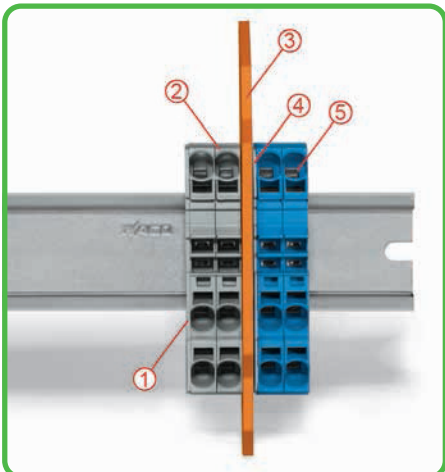

Separator located between Ex e II and Ex i terminal strip

- 1 End plate
- 2 Ex e II terminal blocks
- 3 Ex e/Ex i separator plate
- 4 End plate
- 5 Ex i terminal blocks

According to EN 50020, a minimum distance of 50 mm must be kept between live parts of Ex e and Ex i circuits. The use of Ex e/Ex i separators is a space-saving solution when Ex e and Ex i terminal blocks are mounted on a common carrier rail.

2004 Series Accessories

Modular TOPJOB®S connector,			
6	can be snapped together, for jumper contact slot gray	2004-511	100 (4x25)
Spacer module, can be snapped together, e.g., for bridging commoned terminal blocks			
	gray	2004-549	100 (4x25)
End plate,			
	for modular TOPJOB®S connectors, 1.5 mm thick gray	2004-541	100 (4x25)
Test plug adapter,			
	for 4 mm Ø test plug gray	2009-174	100 (4x25)
Banana plug,			
	for socket 4 mm Ø, color mixed	215-111	50
Testing tap,			
	for max. 2.5 mm ² gray	2009-182	100 (4x25)
Test plug,			
	with 500 mm cable, 2 mm Ø red	210-136	50
Test plug,			
	with 500 mm cable, 2.3 mm Ø yellow	210-137	50
WMB Multi marking system,			
	10 strips with 10 markers per card, stretchable 5 - 5.2 mm plain	793-5501	5
Marking strip, plain,			
	11 mm wide, 50 m roll white	2009-110	1
TOPJOB®S group marker carrier,			
	snap-on type for jumper slot, 5 mm wide gray	2009-191	50 (2x25)
Screwless end stop,			
	for DIN 35 rail, 6 mm wide gray	249-116	100 (4x25)

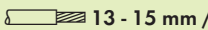
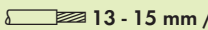
0.5 - 6 (10) mm ² ① 800 V/8 kV/3 ② I _N 41 A (57 A)	AWG 20 - 8 600 V, 50 A ④ 600 V, 50 A ⑤	0.5 - 6 (10) mm ² ① 800 V/8 kV/3 ② I _N 41 A (57 A)	AWG 20 - 8 600 V, 50 A ④ 600 V, 50 A ⑤
Terminal block width 7.5 mm / 0.295 in  13 - 15 mm / 0.55 in ③		Terminal block width 7.5 mm / 0.295 in  13 - 15 mm / 0.55 in ③	

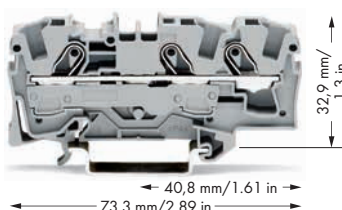
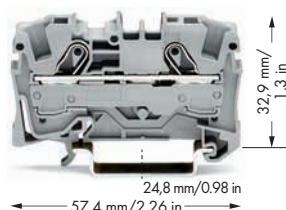

- ① Conductor sizes: 0.5 mm² - 10 mm² "s + f-st"; Push-in conductor sizes: 1 mm² - 10 mm² "s" and 1.5 mm² - 6 mm² "insulated ferrule, 12 mm"
- ② 800 V = rated voltage
8 kV = rated surge voltage
3 = pollution degree
(see Section 14)
- ③ Strip length, see packaging or instructions.
- ④ Suitable for Ex i applications
- ⑤ Suitable for Ex e II applications
550 V, 38 A for 2-conductor terminal blocks
550 V, 36 A for 3-conductor terminal blocks
Jumper 33 A
(see Section 14)
- ⑥ See application notes for:
Ex e/Ex i separator plate, page 19
Step-down jumper, page 23
Star point jumper, page 103
TOPJOB®S connector, page 98

Item No.	Pack. Unit	Item No.	Pack. Unit
2-conductor through terminal block		3-conductor through terminal block	
gray ⑤ 2006-1201 ⑤	50	gray ⑤ 2006-1301 ⑤	25
blue ⑤ 2006-1204 ④ ⑤	50	blue ⑤ 2006-1304 ④ ⑤	25
orange ⑤ 2006-1202 ⑤	50	orange ⑤ 2006-1302 ⑤	25
2-conductor ground terminal block		3-conductor ground terminal block	
green-yellow ⑤ 2006-1207 ⑤	50	green-yellow ⑤ 2006-1307 ⑤	25
2-conductor shield terminal block			
white ⑤ 2006-1208 ⑤	50		

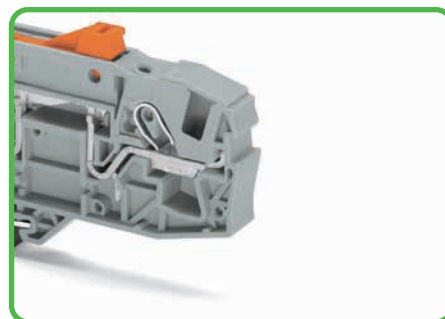

Lockout cap for covering unused clamping units of 2006 Series TOPJOB®S terminal blocks.

Item-Specific Accessories		Item-Specific Accessories	
End and intermediate plate, 1 mm thick		End and intermediate plate, 1 mm thick	
orange 2006-1292 100 (4x25)		orange 2006-1392 100 (4x25)	
gray 2006-1291 100 (4x25)		gray 2006-1391 100 (4x25)	
Separator, oversized, 2 mm thick		Separator, oversized, 2 mm thick	
orange 2006-1294 100 (4x25)		orange 2006-1394 100 (4x25)	
gray 2006-1293 100 (4x25)		gray 2006-1393 100 (4x25)	

2006 Series Accessories		2006 Series Accessories	
Appropriate marking systems: WMB/Marking strips (see Section 13)			
Ex e/Ex i separator, orange, 3 mm thick 120 mm 209-191 50 (2x25)		Step-down jumper, insulated, I _N 32 A light gray 2006-499 50 (2x25)	
Push-in type jumper bar, insulated, I _N 41 A, light gray 2-way 2006-402 50 (2x25) 3-way 2006-403 50 (2x25) 4-way 2006-404 50 (2x25) 5-way 2006-405 50 (2x25)		Protective warning marker, with high-voltage symbol, black, for 5 terminal blocks yellow 2006-115 100 (4x25)	
		Lockout cap, for conductor entry hole and operating slot gray 2006-191 25	
Push-in type jumper bar, insulated, I _N 41 A, light gray from 1 to 3 2006-433 50 (2x25) from 1 to 4 2006-434 50 (2x25) from 1 to 5 2006-435 50 (2x25)		Modular TOPJOB®S connector, can be snapped together, for jumper contact slot gray 2006-511 50 (2x25)	
		Test plug adapter, for 4 mm Ø test plug gray 2009-174 100 (4x25)	
Star point jumper, insulated, I _N = I _N terminal block, light gray 1-3-5 2006-405/011-000 50 (2x25)		WMB Multi marking system, 10 strips with 10 markers per card, stretchable 5 - 5.2 mm plain 793-5501 5	

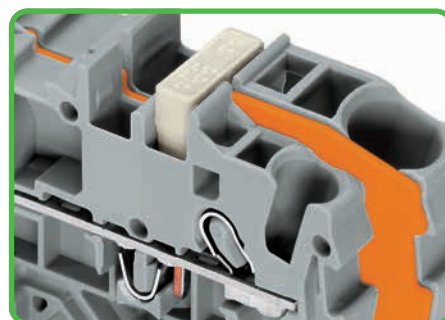

Commoning with step-down jumpers
An end plate must be inserted between the terminal blocks to be jumpered. Step-down jumper 2006-499 commons 6/4 mm² AWG 10/12 (2006/2004 Series) terminal blocks with 4/2.5/1.5 mm² AWG 12/14/16 (2004/2002/2001 Series) terminal blocks. Step-down jumpers are simply pushed down for full insertion, similar to other push-in type jumper bars. Note: The total current flowing shall not exceed the rating of the step-down jumper/push-in type jumper bar.



TOPJOB® S Through/Ground Conductor and Ex Terminal Blocks 10 (16) mm² 2010 Series

CAGE CLAMP® S

1







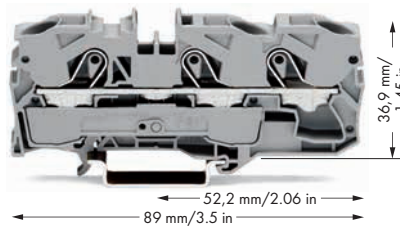
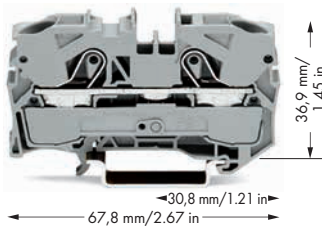

















21

1

0.5 - 10 (16) mm ² ① 800 V/8 kV/3 ② I _N 57 A (76 A)	AWG 20 - 6 600 V, 65 A ^{UL} 600 V, 65 A ^{CE}	0.5 - 10 (16) mm ² ① 800 V/8 kV/3 ② I _N 57 A (76 A)	AWG 20 - 6 600 V, 65 A ^{UL} 600 V, 65 A ^{CE}
Terminal block width 10 mm / 0.394 in  17 - 19 mm / 0.71 in ③		Terminal block width 10 mm / 0.394 in  17 - 19 mm / 0.71 in ③	



- ① Conductor sizes: 0.5 mm² - 16 mm² "s + f-st"; Push-in conductor sizes: 2.5 mm² - 16 mm² "s" and 2.5 mm² - 10 mm² "insulated ferrule, 18 mm"
- ② 800 V = rated voltage
8 kV = rated surge voltage
3 = pollution degree
(see Section 14)
- ③ Strip length, see packaging or instructions.
- ④ Suitable for Ex i applications
- ⑤ Suitable for Ex e II applications
550 V, 51 A for 2-conductor terminal blocks
550 V, 50 A for 3-conductor terminal blocks
(see Section 14)
- ⑥ See application notes for:
Ex e/Ex i separator plate, page 19
Step-down jumper, page 23
Star point jumper, page 103
TOPJOB®S connector, page 98

Item No.	Pack. Unit	Item No.	Pack. Unit
2-conductor through terminal block		3-conductor through terminal block	
 gray ⑤	2010-1201 ⑤ 25	 gray ⑤	2010-1301 ⑤ 25
 blue ⑤	2010-1204 ④ ⑤ 25	 blue ⑤	2010-1304 ④ ⑤ 25
 orange ⑤	2010-1202 ⑤ 25	 orange ⑤	2010-1302 ⑤ 25
2-conductor ground terminal block		3-conductor ground terminal block	
 green-yellow ⑤	2010-1207 ⑤ 25	 green-yellow ⑤	2010-1307 ⑤ 25
2-conductor shield terminal block			
 white	2010-1208 ⑤ 25		
Item-Specific Accessories		Item-Specific Accessories	
End and intermediate plate, 1 mm thick		End and intermediate plate, 1 mm thick	
 orange	2010-1292 100 (4x25)	 orange	2010-1392 100 (4x25)
 gray	2010-1291 100 (4x25)	 gray	2010-1391 100 (4x25)
Ex e/Ex i separator, orange,			
 ⑥	3 mm thick 120 mm 209-191 50 (2x25)		
2010 Series Accessories			
Appropriate marking systems: WMB/Marking strips (see Section 13)			
Push-in type jumper bar, insulated,		Protective warning marker,	
 I _N 57 A, light gray		 with high-voltage symbol, black, for 5 terminal blocks	
2-way	2010-402 50 (2x25)	yellow	2010-115 50 (2x25)
3-way	2010-403 50 (2x25)	Finger guard,	
4-way	2010-404 50 (2x25)	 touchproof cover protects unused conductor entries	
5-way	2010-405 50 (2x25)	yellow	2010-100 100 (4x25)
Push-in type jumper bar, insulated,		Modular TOPJOB®S connector,	
 I _N 57 A, light gray		 ⑥ can be snapped together, for jumper contact slot	
from 1 to 3	2010-433 50 (2x25)	gray	2010-511 50 (2x25)
from 1 to 4	2010-434 50 (2x25)	Test plug adapter,	
from 1 to 5	2010-435 50 (2x25)	 for 4 mm Ø test plug	
		gray	2009-174 100 (4x25)
Star point jumper, insulated,		WMB Multi marking system,	
 ⑥ I _N = I _N terminal block, light gray		 10 strips with 10 markers per card, stretchable 5 - 5.2 mm	
1-3-5	2010-405/011-000 50 (2x25)	plain	793-5501 5
Step-down jumper, insulated,		Marking strip, plain,	
 ⑥ I _N 57 A		 11 mm wide, 50 m roll	
light gray	2016-499 50 (2x25)	white	2009-110 1



Commoning with step-down jumpers
An end plate must be inserted between the terminal blocks to be jumpered. Step-down jumper 2016-499 commons 16/10 mm² AWG 16/8 (2016/2010 Series) terminal blocks with 10/6/4/2.5 mm² AWG 8/10/12/14 (2010/2006/2004/2002 Series) terminal blocks. Step-down jumpers are simply pushed down for full insertion, similar to other push-in type jumper bars.

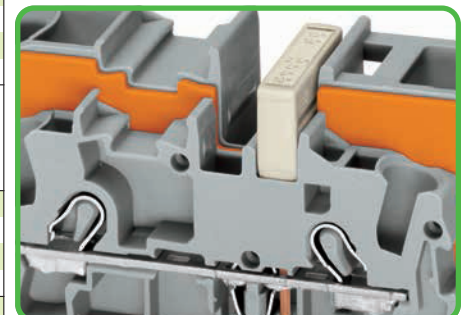

Note:
The total current flowing shall not exceed the rating of the step-down jumper/push-in type jumper bar.

TOPJOB® S Through/Ground Conductor and Ex Terminal Blocks 16 (25 "f-st") mm², 2016 Series



0.5 - 16 (25 "f-st") mm ² ① 800 V/8 kV/3 ② I _N 76 A (90 A)	AWG 20 - 4 600 V, 85 A ④ 600 V, 85 A ⑤	0.5 - 16 (25 "f-st") mm ² ① 800 V/8 kV/3 ② I _N 76 A (90 A)	AWG 20 - 4 600 V, 85 A ④ 600 V, 85 A ⑤
Terminal block width 12 mm / 0.472 in 18 - 20 mm / 0.75 in ③		Terminal block width 12 mm / 0.472 in 18 - 20 mm / 0.75 in ③	

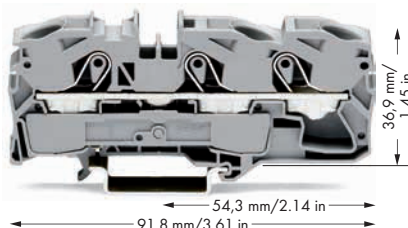
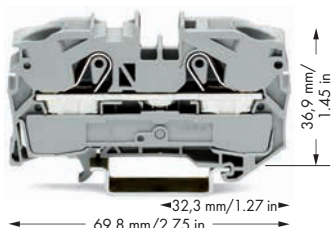

- ① Conductor sizes: 0.5 mm² - 16 mm² "s + f-st", 25 mm² "f-st"; Push-in conductor sizes: 2.5 mm² - 16 mm² "s" and 2.5 mm² - 16 mm² "insulated ferrule, 18 mm"
- ② 800 V = rated voltage
8 kV = rated surge voltage
3 = pollution degree
(see Section 14)
- ③ Strip length, see packaging or instructions.
- ④ Suitable for Ex i applications
- ⑤ Suitable for Ex e II applications
550 V, 70 A for 2-conductor terminal blocks
550 V, 67 A for 3-conductor terminal blocks
Jumper 65 A
(see Section 14)
- ⑥ See application notes for:
Ex e/Ex i separator plate, page 19
Step-down jumper, page 23
Star point jumper, page 103
TOPJOB®S connector, page 99

Item No.	Pack. Unit	Item No.	Pack. Unit
2-conductor through terminal block		3-conductor through terminal block	
gray ⑤	2016-1201 ⑤ 20	gray ⑤	2016-1301 ⑤ 20
blue ⑤	2016-1204 ④ ⑤ 20	blue ⑤	2016-1304 ④ ⑤ 20
orange ⑤	2016-1202 ⑤ 20	orange ⑤	2016-1302 ⑤ 20
2-conductor ground terminal block, 15mm-high DIN 35 rails shall be used for a current load higher than 76A!		3-conductor ground terminal block, 15mm-high DIN 35 rails shall be used for a current load higher than 76A!	
green-yellow ⑤	2016-1207 ⑤ 20	green-yellow ⑤	2016-1307 ⑤ 20
2-conductor shield terminal block, 15mm-high DIN 35 rails shall be used for a current load higher than 76A!			
white	2016-1208 ⑤ 20		
Item-Specific Accessories		Item-Specific Accessories	
End and intermediate plate, 1 mm thick		End and intermediate plate, 1 mm thick	
orange	2016-1292 100 (4x25)	orange	2016-1392 100 (4x25)
gray	2016-1291 100 (4x25)	gray	2016-1391 100 (4x25)
Ex e/Ex i separator, orange, ⑥ 3 mm thick			
	120 mm 209-191 50 (2x25)		
2016 Series Accessories Appropriate marking systems: WMB/Marking strips (see Section 13)			
Push-in type jumper bar, insulated, I _N 76 A, light gray		Step-down jumper, insulated, ⑥ I _N 57 A, light gray	
2-way	2016-402 50 (2x25)	light gray	2016-499 50 (2x25)
3-way	2016-403 50 (2x25)	Protective warning marker,	
4-way	2016-404 50 (2x25)	with high-voltage symbol, black, for 5 terminal blocks	
5-way	2016-405 50 (2x25)	yellow	2016-115 50 (2x25)
Push-in type jumper bar, insulated, I _N 76 A, light gray		Modular TOPJOB®S connector, ⑥ can be snapped together, for jumper contact slot	
from 1 to 3	2016-433 50 (2x25)	gray	2016-511 50 (2x25)
from 1 to 4	2016-434 50 (2x25)	Finger guard,	
from 1 to 5	2016-435 50 (2x25)	touchproof cover protects unused conductor entries	
		yellow	2016-100 100 (4x25)
Star point jumper, insulated, ⑥ I _N = I _N terminal block, light gray		Test plug adapter,	
1-3-5	2016-405/011-000 50 (2x25)	for 4 mm Ø test plug	
		gray	2009-174 100 (4x25)

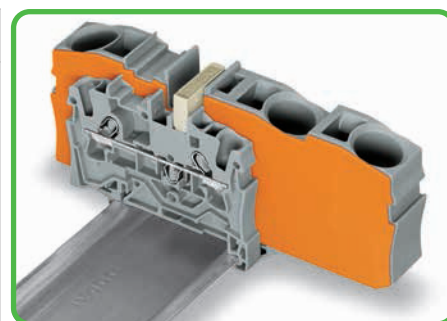

Commoning with step-down jumpers
An end plate must be inserted between the terminal blocks to be jumpered. Step-down jumper 2016-499 commons 16/10 mm² AWG 16/8 (2016/2010 Series) terminal blocks with 10/6/4/2.5 mm² AWG 8/10/12/14 (2010/2006/2004/2002 Series) terminal blocks. Step-down jumpers are simply pushed down for full insertion, similar to other push-in type jumper bars.



Inserting a finger guard seals unused conductor entries.

- Simply Jumpered - Commoning via Step-Down Jumpers and Push-In Type Jumper Bars

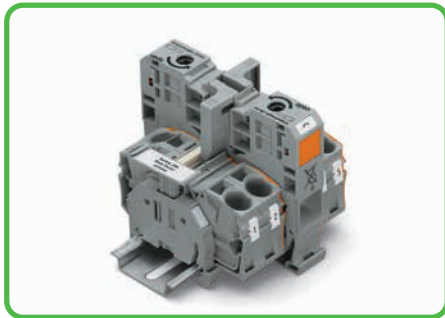

Commoning from 35 mm²/AWG 2 POWER CAGE CLAMP terminal blocks to 10/16 mm² (AWG 8/10) TOPJOB®S terminal blocks

Step-down jumpers may common terminal blocks of different sizes, without losing a conductor clamping point. This can be beneficial on long conductor runs where voltage drop can be a problem. A large conductor can be easily connected to smaller conductors at the distribution point.

Step-down jumpers are simply pushed down for full insertion, in the same way as all other push-in jumpers. Commoning may be made in either direction using the special thin end plate to cover the open side. Further terminal blocks of the smaller cross section may be commoned using standard push-in type jumper bars.

In this case, pay attention that:
The total current flowing does not exceed the rating of the step-down jumper.

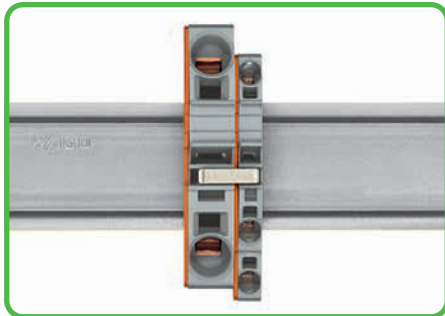

Using step-down jumpers, an end plate must be inserted between the terminal blocks to be commoned.

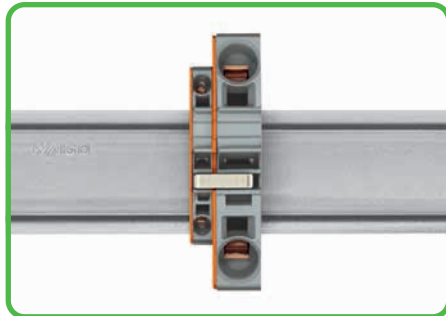

Step-down jumper 2016-499 commons 16/10 mm² AWG 16/8 (2016/2010 Series) terminal blocks with 10/6/4/2.5 mm² AWG 8/10/12/14 (2010/2005/2004/2002 Series) terminal blocks. Step-down jumper 2006-499 commons 6/4 mm² AWG 10/12 (2006/2004 Series) terminal blocks with 4/2.5/1.5 mm² AWG 12/14/16 (2004/2002/2001) terminal blocks.

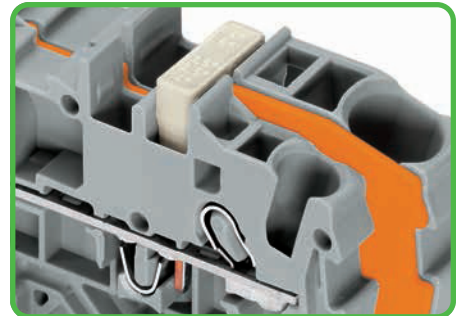

Commoning with step-down jumpers
An end plate must be inserted between the terminal blocks to be jumpered. Step-down jumper 2016-499 commons 16/10 mm² AWG 16/8 (2016/2010 Series) terminal blocks with 10/6/4/2.5 mm² AWG 8/10/12/14 (2010/2006/2004/2002 Series) terminal blocks. Step-down jumpers are simply pushed down for full insertion, similar to other push-in type jumper bars.

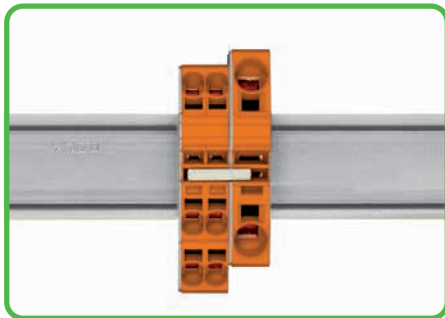

Commoning with push-in type jumper bars
Commoning via open terminal side with end plate allows jumpering over two cross section sizes for 16 mm²/AWG 6 and 10 mm²/AWG 8 and one cross section size for 6/4/2.5 mm² (AWG 10/12/14); e.g., from 16 mm²/AWG 6 to 6 mm²/AWG 10 (see illustration above) or from 10 mm²/AWG 8 to 4 mm²/AWG 12.

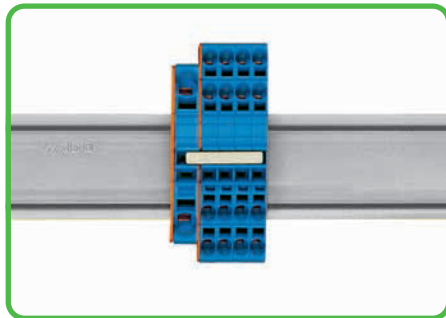

Commoning with push-in type jumper bars
Commoning via closed terminal side with end plate allows jumpering over two cross section sizes; e.g., from 16 mm²/AWG 6 to 6 mm²/AWG 10 or from 6 mm²/AWG 10 to 2.5 mm²/AWG 14 (see illustration above).

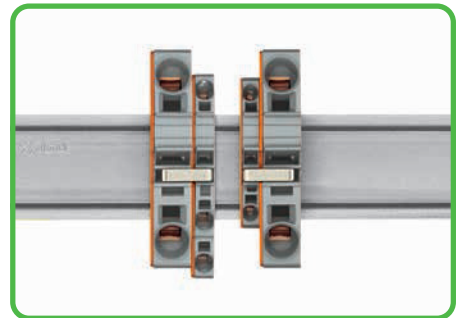



Note:
The total current flowing shall not exceed the rating of the step-down jumper/push-in type jumper bar.

TOPJOB® S

Double-Deck Terminal Blocks 1 (1.5) mm²

2000 Series

<p>0.14 - 1 (1.5) mm² ① AWG 24 - 16 500 V/6 kV/3 ② I_N 13.5 A (16 A)</p> <p>Terminal block width 3.5 mm / 0.138 in  9 - 11 mm / 0.39 in ③</p>	<p>0.14 - 1 (1.5) mm² ① AWG 24 - 16 500 V/6 kV/3 ② I_N 13.5 A (16 A)</p> <p>Terminal block width 3.5 mm / 0.138 in  9 - 11 mm / 0.39 in ③</p>	<p>0.14 - 1 (1.5) mm² ① AWG 24 - 16 500 V/6 kV/3 ② I_N 13.5 A (16 A)</p> <p>Terminal block width 3.5 mm / 0.138 in  9 - 11 mm / 0.39 in ③</p>
---	--	--

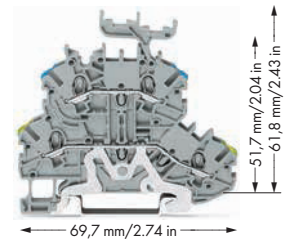
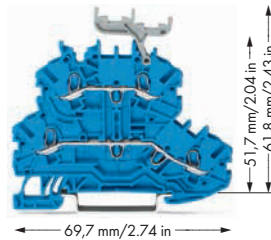
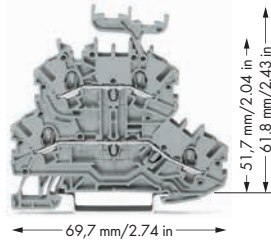

Item No.	Pack. Unit	Item No.	Pack. Unit	Item No.	Pack. Unit
Through/through terminal block, with marker carrier, gray housing		Through/through terminal block, with marker carrier, blue housing		Ground conductor/through terminal block, with marker carrier, gray housing	
○ L/L 2000-2231	50	● N/N 2000-2234	50	○ PE/N 2000-2247	50
○ N/L 2000-2232	50			○ PE/L 2000-2257	50
○ L/N 2000-2233	50				
Through/through terminal block, without marker carrier, gray housing		Through/through terminal block, without marker carrier, blue housing		Ground conductor/through terminal block, without marker carrier, gray housing	
○ L/L 2000-2201	50	● N/N 2000-2204	50	○ PE/N 2000-2217	50
○ N/L 2000-2202	50			○ PE/L 2000-2227	50
○ L/N 2000-2203	50				

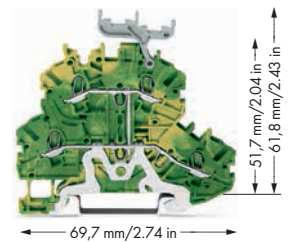
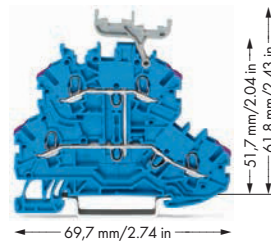
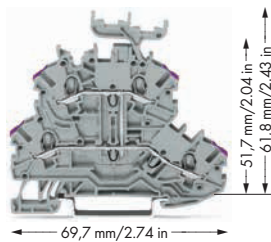

Item No.	Pack. Unit	Item No.	Pack. Unit	Item No.	Pack. Unit
4-conductor through terminal block, with marker carrier, internal comming, conductor entry position colored in violet, gray housing		4-conductor through terminal block, with marker carrier, internal comming, conductor entry position colored in violet, blue housing		4-conductor ground terminal block, with marker carrier, internal comming, green-yellow housing	
○ L 2000-2238	50	● N 2000-2239	50	● PE 2000-2237	50
4-conductor through terminal block, without marker carrier, internal comming, conductor entry position colored in violet, gray housing		4-conductor through terminal block, without marker carrier, internal comming, conductor entry position colored in violet, blue housing		4-conductor ground terminal block, without marker carrier, internal comming, green-yellow housing	
○ L 2000-2208	50	● N 2000-2209	50	● PE 2000-2207	50

0.14 - 1 (1.5) mm² ① AWG 24 - 16

500 V/6 kV/3 ②

I_N 13.5 A (16 A)

Terminal block width 3.5 mm / 0.138 in

9 - 11 mm / 0.39 in ③

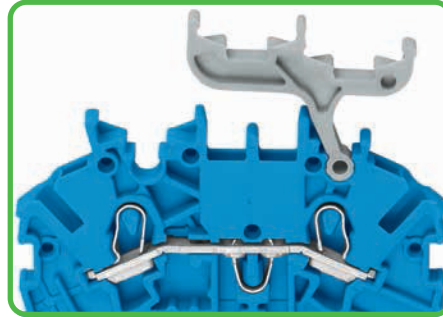
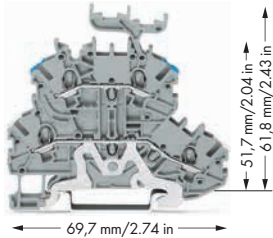

Double-deck terminal block assembly

A double-deck marker carrier can be fitted retrospectively to double-deck terminal blocks without marker carrier.



- ① Conductor sizes: 0.14 mm² - 1.5 mm² "s + f-st"; Push-in conductor sizes: 0.5 mm² - 1.5 mm² "s" and 0.5 mm² - 0.75 mm² "insulated ferrule, 10 mm"
- ② 500 V = rated voltage
6 kV = rated surge voltage
3 = pollution degree
(see Section 14)
- ③ Strip length, see packaging or instructions.
- ④ See application notes for:
Colored push-in type jumper bars, page 101
Vertical jumper, page 105

Item No.	Pack. Unit	2000 Series Accessories	
Shield conductor/through terminal block, with marker carrier, gray housing		Appropriate marking systems: WMB/Marking strips (see Section 13)	
Shield/N 2000-2248	50	End and intermediate plate, 0.7 mm thick	Test plug adapter,
Shield/L 2000-2258	50	orange 2000-2292 25	for 4 mm Ø test plug
		gray 2000-2291 25	gray 2009-174 100 (4x25)
Shield conductor/through terminal block, without marker carrier, gray housing		Push-in type jumper bar, insulated,	Banana plug,
Shield/N 2000-2218	50	④ I _N 14 A, light gray	for socket 4 mm Ø, color mixed
Shield/L 2000-2228	50	2-way 2000-402 200 (8x25)	215-111 50
		3-way 2000-403 200 (8x25)	Testing tap,
		4-way 2000-404 200 (8x25)	for max. 2.5 mm ²
		5-way 2000-405 100 (4x25)	gray 2009-182 100 (4x25)
		6-way 2000-406 100 (4x25)	
		7-way 2000-407 100 (4x25)	
		8-way 2000-408 100 (4x25)	
		9-way 2000-409 100 (4x25)	
		10-way 2000-410 100 (4x25)	
		Push-in type jumper bar, insulated,	
		I _N 14 A, light gray	
		from 1 to 3 2000-433 200 (8x25)	
		from 1 to 4 2000-434 200 (8x25)	
		from 1 to 5 2000-435 100 (4x25)	
		from 1 to 6 2000-436 100 (4x25)	
		from 1 to 7 2000-437 100 (4x25)	
		from 1 to 8 2000-438 100 (4x25)	
		from 1 to 9 2000-439 100 (4x25)	
		from 1 to 10 2000-440 100 (4x25)	
		Double-deck vertical jumper, insulated,	
		④ I _N 13.5 A, light gray 2000-492 100 (4x25)	
		Protective warning marker,	
		with high-voltage symbol, black, for 5 terminal blocks	
		yellow 2000-115 100 (4x25)	
		Double-deck marker carrier,	
		pivoting	
		gray 2000-121 50 (2x25)	
		WMB Multi marking system,	
		10 strips with 10 markers per card, for 3.5 mm terminal block width	
		plain 793-3501 5	
		Marking strip, plain,	
		11 mm wide, 50 m roll	
		white 2009-110 1	

TOPJOB® S

Double-Deck Terminal Blocks 1 (1.5) mm²

2000 Series

<p>0.14 - 1 (1.5) mm² ① AWG 24 - 16 800 V/8 kV/3 ② I_N 13.5 A (16 A)</p> <p>Terminal block width 4.2 mm / 0.165 in  9 - 11 mm / 0.39 in ③</p>	<p>0.14 - 1 (1.5) mm² ① AWG 24 - 16 800 V/8 kV/3 ② I_N 13.5 A (16 A)</p> <p>Terminal block width 4.2 mm / 0.165 in  9 - 11 mm / 0.39 in ③</p>	<p>0.14 - 1 (1.5) mm² ① AWG 24 - 16 800 V/8 kV/3 ② I_N 13.5 A (16 A)</p> <p>Terminal block width 4.2 mm / 0.165 in  9 - 11 mm / 0.39 in ③</p>
---	--	--

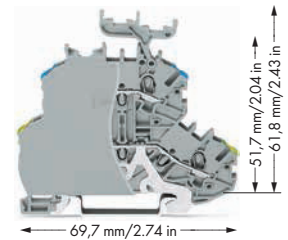
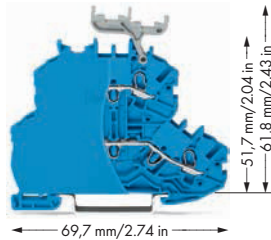
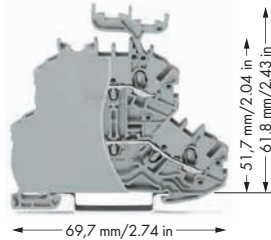

Item No.	Pack. Unit	Item No.	Pack. Unit	Item No.	Pack. Unit
Through/through terminal block, with end plate, with marker carrier, gray housing		Through/through terminal block, with end plate, with marker carrier, blue housing		Ground conductor/through terminal block, with end plate, with marker carrier, gray housing	
○ L/L	2000-2231/099-000 50	● N/N	2000-2234/099-000 50	○ PE/N	2000-2247/099-000 50
○ N/L	2000-2232/099-000 50			○ PE/L	2000-2257/099-000 50
○ L/N	2000-2233/099-000 50				
Through/through terminal block, with end plate, without marker carrier, gray housing		Through/through terminal block, with end plate, without marker carrier, blue housing		Ground conductor/through terminal block, with end plate, without marker carrier, gray housing	
○ L/L	2000-2201/099-000 50	● N/N	2000-2204/099-000 50	○ PE/N	2000-2217/099-000 50
○ N/L	2000-2202/099-000 50			○ PE/L	2000-2227/099-000 50
○ L/N	2000-2203/099-000 50				

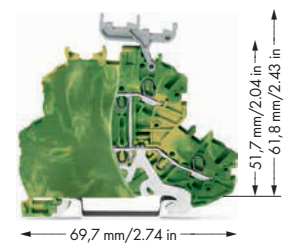
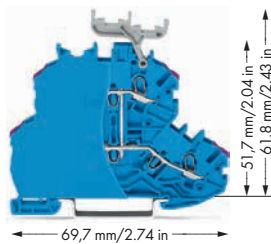
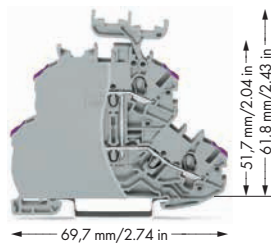

Item No.	Pack. Unit	Item No.	Pack. Unit	Item No.	Pack. Unit
4-conductor through terminal block, with end plate, with marker carrier, internal commoning, conductor entry position colored in violet, gray housing		4-conductor through terminal block, with end plate, with marker carrier, internal commoning, conductor entry position colored in violet, blue housing		4-conductor ground terminal block, with end plate, with marker carrier, internal commoning, green-yellow housing	
○ L	2000-2238/099-000 50	● N	2000-2239/099-000 50	● PE	2000-2237/099-000 50
4-conductor through terminal block, with end plate, without marker carrier, internal commoning, conductor entry position colored in violet, gray housing		4-conductor through terminal block, with end plate, without marker carrier, internal commoning, conductor entry position colored in violet, blue housing		4-conductor ground terminal block, with end plate, without marker carrier, internal commoning, green-yellow housing	
○ L	2000-2208/099-000 50	● N	2000-2209/099-000 50	● PE	2000-2207/099-000 50

0.14 - 1 (1.5) mm² ① AWG 24 - 16
 800 V/8 kV/3 ②
 I_N 13.5 A (16 A)
 Terminal block width 4.2 mm / 0.165 in
 ③ 9 - 11 mm / 0.39 in

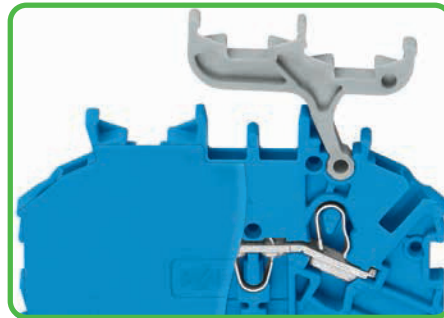

Double-deck terminal block assembly
 A double-deck marker carrier can be fitted retrospectively to double-deck terminal blocks without marker carrier.

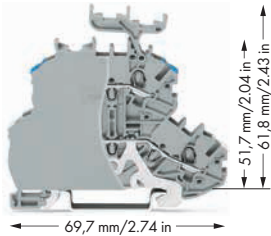



- ① Conductor sizes: 0.14 mm² - 1.5 mm² "s + f-st";
 Push-in conductor sizes: 0.5 mm² - 1.5 mm² "s"
 and 0.5 mm² - 0.75 mm² "insulated ferrule, 10 mm"
- ② 800 V = rated voltage
 8 kV = rated surge voltage
 3 = pollution degree
 (see Section 14)
- ③ Strip length, see packaging or instructions.
- ④ See application notes for:
 Vertical jumper, page 105

Item No.	Pack. Unit	2000 Series Accessories	
Shield conductor/through terminal block, with end plate, with marker carrier,		Appropriate marking systems: WMB/Marking strips (see Section 13)	
gray housing		End and intermediate plate, 0.7 mm thick	Test plug adapter,
Shield/N	2000-2248/099-000 50	orange 2000-2292 25	for 4 mm Ø test plug
Shield/L	2000-2258/099-000 50	gray 2000-2291 25	gray 2009-174 100 (4x25)
Shield conductor/through terminal block, with end plate, without marker carrier,		Push-in type jumper bar, insulated,	Testing tap,
gray housing		I _N 18 A,	for max. 2.5 mm ²
Shield/N	2000-2218/099-000 50	light gray	gray 2009-182 100 (4x25)
Shield/L	2000-2228/099-000 50	2-way 2001-402 200 (8x25)	Banana plug,
		3-way 2001-403 200 (8x25)	for socket 4 mm Ø,
		4-way 2001-404 200 (8x25)	color mixed
		5-way 2001-405 100 (4x25)	215-111 50
		6-way 2001-406 100 (4x25)	WMB Inline, plain,
		7-way 2001-407 100 (4x25)	stretchable 4 - 4.2 mm,
		8-way 2001-408 100 (4x25)	2,000 WMB markers, 4 mm, on roll
		9-way 2001-409 100 (4x25)	white 2009-114 1
		10-way 2001-410 100 (4x25)	WMB Multi marking system,
Push-in type jumper bar, insulated,		I _N 18 A,	10 strips with 10 markers per card,
		light gray	stretchable 4 - 4.2 mm
		from 1 to 3 2001-433 200 (8x25)	plain 793-4501 5
		from 1 to 4 2001-434 200 (8x25)	WMB Multi marking system, plain,
		from 1 to 5 2001-435 100 (4x25)	10 strips with 10 markers per card,
		from 1 to 6 2001-436 100 (4x25)	stretchable 4 - 4.2 mm
		from 1 to 7 2001-437 100 (4x25)	yellow 793-4501/000-002
		from 1 to 8 2001-438 100 (4x25)	red 793-4501/000-005
		from 1 to 9 2001-439 100 (4x25)	blue 793-4501/000-006
		from 1 to 10 2001-440 100 (4x25)	gray 793-4501/000-007
			orange 793-4501/000-012
			light green 793-4501/000-017
			green 793-4501/000-023
			violet 793-4501/000-024
			5
Double-deck vertical jumper, insulated,		I _N 13.5 A	
④		light gray 2000-492 100 (4x25)	
Protective warning marker,		with high-voltage symbol, black,	
		for 5 terminal blocks	
		yellow 2001-115 100 (4x25)	
Double-deck marker carrier,		pivoting	
		gray 2000-121 50 (2x25)	
Marking strip, plain,		11 mm wide,	
		50 m roll	
		white 2009-110 1	

TOPJOB® S

Double-Deck Terminal Blocks 2.5 (4) mm²

2002 Series

<p>0.25 - 2.5 (4) mm² ① AWG 22 - 12 500 V/6 kV/3 ② I_N 24 A (28 A)</p> <p>Terminal block width 5.2 mm / 0.205 in  10 - 12 mm / 0.43 in ③</p>	<p>0.25 - 2.5 (4) mm² ① AWG 22 - 12 500 V/6 kV/3 ② I_N 24 A (28 A)</p> <p>Terminal block width 5.2 mm / 0.205 in  10 - 12 mm / 0.43 in ③</p>	<p>0.25 - 2.5 (4) mm² ① AWG 22 - 12 500 V/6 kV/3 ② I_N 24 A (28 A)</p> <p>Terminal block width 5.2 mm / 0.205 in  10 - 12 mm / 0.43 in ③</p>
--	---	---

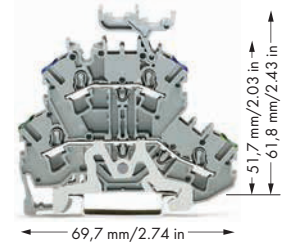
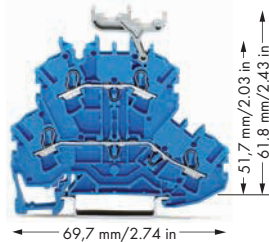
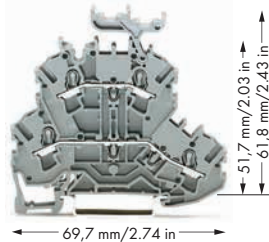

Item No.	Pack. Unit	Item No.	Pack. Unit	Item No.	Pack. Unit
Through/through terminal block, with marker carrier, gray housing		Through/through terminal block, with marker carrier, blue housing		Ground conductor/through terminal block, with marker carrier, gray housing	
○ L/L ☒ 2002-2231 ⑤	50	● N/N ☒ 2002-2234 ④ ⑤	50	○ PE/N ☒ 2002-2247 ⑤	50
○ N/L ☒ 2002-2232 ⑤	50			○ PE/L ☒ 2002-2257 ⑤	50
○ L/N ☒ 2002-2233 ⑤	50				
Through/through terminal block, without marker carrier, gray housing		Through/through terminal block, without marker carrier, blue housing		Ground conductor/through terminal block, without marker carrier, gray housing	
○ L/L ☒ 2002-2201 ⑤	50	● N/N ☒ 2002-2204 ④ ⑤	50	○ PE/N ☒ 2002-2217 ⑤	50
○ N/L ☒ 2002-2202 ⑤	50			○ PE/L ☒ 2002-2227 ⑤	50
○ L/N ☒ 2002-2203 ⑤	50				
Other terminal blocks with the same profile:					
Diode	2002-2211/1000-410	Page86			
LED	2002-2221/1000-434	Page86			

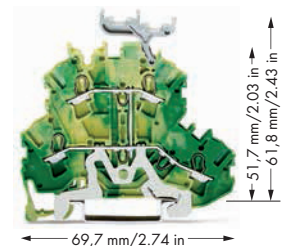
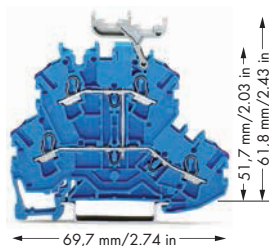
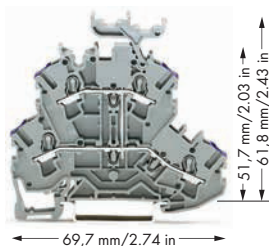

Item No.	Pack. Unit	Item No.	Pack. Unit	Item No.	Pack. Unit
4-conductor through terminal block, with marker carrier, internal commoning, conductor entry position colored in violet, gray housing		4-conductor through terminal block, with marker carrier, internal commoning, conductor entry position colored in violet, blue housing		4-conductor ground terminal block, with marker carrier, internal commoning, green-yellow housing	
○ L ☒ 2002-2238 ⑤	50	● N ☒ 2002-2239 ④ ⑤	50	● PE ☒ 2002-2237 ⑤	50
4-conductor through terminal block, without marker carrier, internal commoning, conductor entry position colored in violet, gray housing		4-conductor through terminal block, without marker carrier, internal commoning, conductor entry position colored in violet, blue housing		4-conductor ground terminal block, without marker carrier, internal commoning, green-yellow housing	
○ L ☒ 2002-2208 ⑤	50	● N ☒ 2002-2209 ④ ⑤	50	● PE ☒ 2002-2207 ⑤	50

0.25 - 2.5 (4) mm² ① | AWG 22 - 12
500 V/6 kV/3 ②
I_N 24 A (28 A)

Terminal block width 5.2 mm / 0.205 in
10 - 12 mm / 0.43 in ③

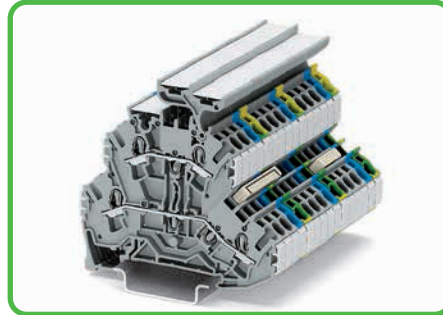
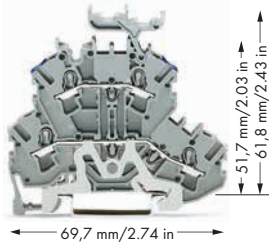



Double-deck terminal block assembly

- ① Conductor sizes: 0.25 mm² - 4 mm² "s + f-st"; Push-in conductor sizes: 0.75 mm² - 4 mm² "s" and 0.75 mm² - 2.5 mm² "insulated ferrule, 12 mm"
- ② 500 V = rated voltage
6 kV = rated surge voltage
3 = pollution degree
(see Section 14)
- ③ Strip length, see packaging or instructions.
- ④ Suitable for Ex i applications
- ⑤ Suitable for Ex e II applications
440 V, 20 A
Jumper 18 A
(see Section 14)
- ⑥ See application notes for:
Ex e/Ex i separator plate, page 19
Colored push-in type jumper bars, page 101
Vertical jumper, page 105

2002 Series Accessories

Appropriate marking system
(see Section 13)

End and intermediate plate, 0.8 mm thick			
	orange	2002-2292	100 (4x25)
	gray	2002-2291	100 (4x25)

Ex e/Ex i separator, orange,			
⑥ 	3 mm thick		
	125.5 mm	209-192	50 (2x25)

Double-deck marker carrier,			
	pivoting		
	gray	2002-121	50 (2x25)



Insulation stop,			
	5 pcs/strip, 0.25 - 0.5 mm ²		
	light gray	2002-171	200 (8x25)

Insulation stop,			
	5 pcs/strip, 0.75 - 1 mm ²		
	dark gray	2002-172	200 (8x25)

Push-in type jumper bar, insulated,			
⑥ 	I _N 25 A, light gray		
	2-way	2002-402	200 (8x25)
	3-way	2002-403	200 (8x25)
	4-way	2002-404	200 (8x25)
	5-way	2002-405	100 (4x25)
	6-way	2002-406	100 (4x25)
	7-way	2002-407	100 (4x25)
	8-way	2002-408	100 (4x25)
	9-way	2002-409	100 (4x25)
	10-way	2002-410	100 (4x25)



Push-in type jumper bar, insulated,			
	I _N 25 A, light gray		
	from 1 to 3	2002-433	200 (8x25)
	from 1 to 4	2002-434	200 (8x25)
	from 1 to 5	2002-435	100 (4x25)
	from 1 to 6	2002-436	100 (4x25)
	from 1 to 7	2002-437	100 (4x25)
	from 1 to 8	2002-438	100 (4x25)
	from 1 to 9	2002-439	100 (4x25)
	from 1 to 10	2002-440	100 (4x25)

Double-deck vertical jumper, insulated,			
⑥ 	I _N 24 A, light gray	2002-492	100 (4x25)
	orange	2002-492/000-012	

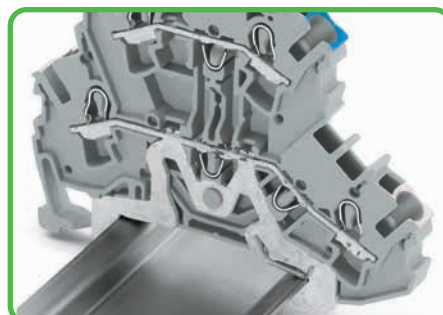
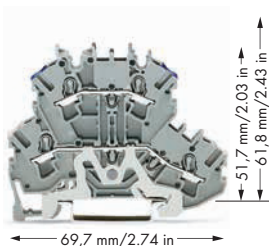
Item No.	Pack. Unit
Shield conductor/through terminal block, with marker carrier, gray housing	
 Shield/N	2002-2248 50
 Shield/L	2002-2258 50





The ground conductor or shield terminal blocks have a contact foot in the bottom level, automatically establishing direct contact to the carrier rail.
The flexible double-deck marker carrier, which is placed above the wiring levels, can be pushed aside during the wiring or commoning operation. The marker carrier has two levels for two different WMB markers relating to the two decks of the terminal blocks.
With a terminal block width of only 5.2 mm an effective width of only 2.6 mm for terminal blocks of same or different potentials can be realized for conductor sizes from 0.25 mm² to 4 mm² (AWG 22 - 12).
For protection against external interfering signals, an increasing number of shielded control cables are being used.
Shield terminal blocks for front-entry are suitable for connecting the cable braid. Like ground conductor terminal blocks for front-entry, they are equipped with a grounding foot for direct electrical connection to the rail, however they differ significantly by their white insulated housing. Shield terminal blocks can be directly mounted beside signal-conductor terminal blocks and provide excellent deflection of interfering signals.

Item No.	Pack. Unit
Shield conductor/through terminal block, without marker carrier, gray housing	
 Shield/N	2002-2218 50
 Shield/L	2002-2228 50

TOPJOB® S

Double-Deck Terminal Blocks 2.5 (4) mm²

2002 Series

0.25 - 2.5 (4) mm² ① AWG 22 - 12 800 V/8 kV/3 ② I_N 24 A 600 V, 20 A ③ Terminal block width 6.2 mm / 0.244 in  10 - 12 mm / 0.43 in ③	0.25 - 2.5 (4) mm² ① AWG 22 - 12 800 V/8 kV/3 ② I_N 24 A 600 V, 20 A ③ Terminal block width 6.2 mm / 0.244 in  10 - 12 mm / 0.43 in ③	0.25 - 2.5 (4) mm² ① AWG 22 - 12 800 V/8 kV/3 ② I_N 24 A Terminal block width 6.2 mm / 0.244 in  10 - 12 mm / 0.43 in ③
---	--	---

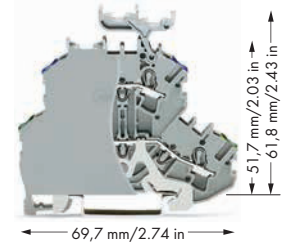
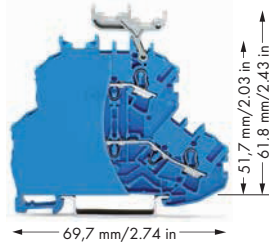
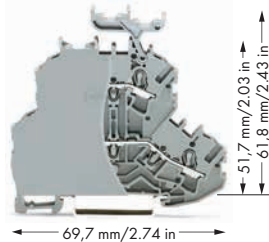

Item No.	Pack. Unit	Item No.	Pack. Unit	Item No.	Pack. Unit
Through/through terminal block, with end plate, with marker carrier, gray housing		Through/through terminal block, with end plate, with marker carrier, blue housing		Ground conductor/through terminal block, with end plate, with marker carrier, gray housing	
○ L/L	2002-2231/099-000 50	● N/N	2002-2234/099-000 ④ 50	○ PE/N	2002-2247/099-000 50
○ N/L	2002-2232/099-000 50			○ PE/L	2002-2257/099-000 50
○ L/N	2002-2233/099-000 50				
Through/through terminal block, with end plate, without marker carrier, gray housing		Through/through terminal block, with end plate, without marker carrier, blue housing		Ground conductor/through terminal block, with end plate, without marker carrier, gray housing	
○ L/L	2002-2201/099-000 50	● N/N	2002-2204/099-000 ④ 50	○ PE/N	2002-2217/099-000 50
○ N/L	2002-2202/099-000 50			○ PE/L	2002-2227/099-000 50
○ L/N	2002-2203/099-000 50				
Other terminal blocks with the same profile:					
Diode	2002-2211/1000-410	Page86			
LED	2002-2221/1000-434	Page86			

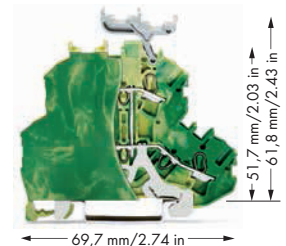
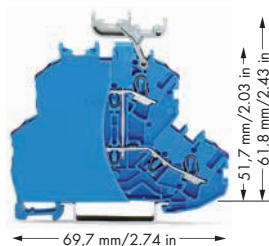
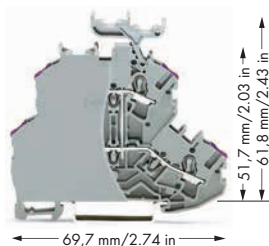

Item No.	Pack. Unit	Item No.	Pack. Unit	Item No.	Pack. Unit
4-conductor through terminal block, with end plate, with marker carrier, internal commoning, conductor entry position colored in violet, gray housing		4-conductor through terminal block, with end plate, with marker carrier, internal commoning, conductor entry position colored in violet, blue housing		4-conductor ground terminal block, with end plate, with marker carrier, internal commoning, green-yellow housing	
○ L	2002-2238/099-000 50	● N	2002-2239/099-000 ④ 50	● PE	2002-2237/099-000 50
4-conductor through terminal block, with end plate, without marker carrier, internal commoning, conductor entry position colored in violet, gray housing		4-conductor through terminal block, with end plate, without marker carrier, internal commoning, conductor entry position colored in violet, blue housing		4-conductor ground terminal block, with end plate, without marker carrier, internal commoning, green-yellow housing	
○ L	2002-2208/099-000 50	● N	2002-2209/099-000 ④ 50	● PE	2002-2207/099-000 50

0.25 - 2.5 (4) mm² ① | AWG 22 - 12
 800 V/8 kV/3 ②
 I_N 24 A
 Terminal block width 6.2 mm / 0.244 in
 10 - 12 mm / 0.43 in ③

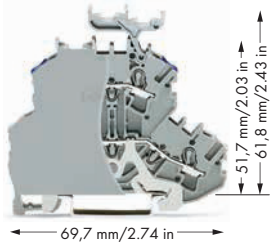

Protective warning marker and insulation stop must be applied individually. Due to the 6.2 mm width of double-deck terminal blocks with end plate, 2004 Series jumpers must be used.



- ① Conductor sizes: 0.25 mm² - 4 mm² "s + f-st"; Push-in conductor sizes: 0.75 mm² - 4 mm² "s" and 0.75 mm² - 2.5 mm² "insulated ferrule, 12 mm"
- ② 800 V = rated voltage
8 kV = rated surge voltage
3 = pollution degree
(see Section 14)
- ③ Strip length, see packaging or instructions.
- ④ Suitable for Ex i applications
- ⑤ See application notes for:
Vertical jumper, page 105

Item No.	Pack. Unit	2002 Series Accessories	
Shield conductor/through terminal block, with end plate, with marker carrier, gray housing		Appropriate marking systems: WMB/Marking strips/WMB Inline (see Section 13)	
Shield/N	2002-2248/099-000 50	End and intermediate plate, 0.8 mm thick orange 2002-2292 100 (4x25) gray 2002-2291 100 (4x25)	Test plug adapter, for 4 mm Ø test plug gray 2009-174 100 (4x25)
Shield/L	2002-2258/099-000 50		
Shield conductor/through terminal block, with end plate, without marker carrier, gray housing		Double-deck marker carrier, pivoting gray 2002-121 50 (2x25)	
Shield/N	2002-2218/099-000 50	Insulation stop, 5 pcs/strip, 0.25 - 0.5 mm ² light gray 2002-171 200 (8x25)	Banana plug, for socket 4 mm Ø, color mixed 215-111 50
Shield/L	2002-2228/099-000 50		
Insulation stop, 5 pcs/strip, 0.75 - 1 mm ² dark gray 2002-172 200 (8x25)		WMB Multi marking system, 10 strips with 10 markers per card, stretchable 5 - 5.2 mm plain 793-5501 5	
Push-in type jumper bar, insulated, I _N 32 A, light gray		WMB Multi marking system, plain, 10 strips with 10 markers per card, stretchable 5 - 5.2 mm	
	2-way 2004-402 200 (8x25)	yellow 793-5501/000-002	
	3-way 2004-403 200 (8x25)	red 793-5501/000-005	
	4-way 2004-404 100 (4x25)	blue 793-5501/000-006	
	5-way 2004-405 100 (4x25)	gray 793-5501/000-007	
	6-way 2004-406 100 (4x25)	orange 793-5501/000-012	
	7-way 2004-407 100 (4x25)	light green 793-5501/000-017	
	8-way 2004-408 100 (4x25)	green 793-5501/000-023	
	9-way 2004-409 100 (4x25)	violet 793-5501/000-024	
	10-way 2004-410 100 (4x25)	5	
Push-in type jumper bar, insulated, I _N 32 A, light gray		Marking strip, plain, 11 mm wide, 50 m roll white 2009-110 1	
	from 1 to 3 2004-433 200 (8x25)		
	from 1 to 4 2004-434 200 (8x25)		
	from 1 to 5 2004-435 100 (4x25)		
	from 1 to 6 2004-436 100 (4x25)		
	from 1 to 7 2004-437 100 (4x25)		
	from 1 to 8 2004-438 100 (4x25)		
	from 1 to 9 2004-439 100 (4x25)		
	from 1 to 10 2004-440 100 (4x25)		
Double-deck vertical jumper, insulated, I _N 24 A			
	light gray 2002-492 100 (4x25)		
	orange 2002-492/000-012		
Protective warning marker, with high-voltage symbol, black, for 5 terminal blocks			
	yellow 2002-115 100 (4x25)		

TOPJOB® S

4-Conductor, Double-Deck Terminal Blocks 2.5 (4) mm²

2002 Series

<p>0.25 - 2.5 (4) mm² ① AWG 22 - 12 800 V/8 kV/3 ② I_N 24 A (28 A)</p> <p>Terminal block width 5.2 mm / 0.205 in  10 - 12 mm / 0.43 in ③</p>	<p>0.25 - 2.5 (4) mm² ① AWG 22 - 12 800 V/8 kV/3 ② I_N 24 A (28 A)</p> <p>Terminal block width 5.2 mm / 0.205 in  10 - 12 mm / 0.43 in ③</p>	<p>0.25 - 2.5 (4) mm² ① AWG 22 - 12 800 V/8 kV/3 ② I_N 24 A (28 A)</p> <p>Terminal block width 5.2 mm / 0.205 in  10 - 12 mm / 0.43 in ③</p>
--	---	---

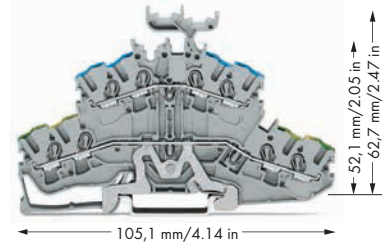
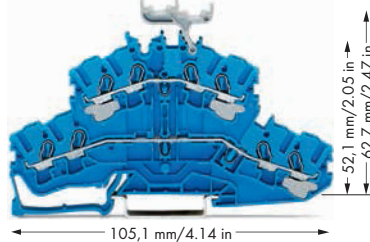
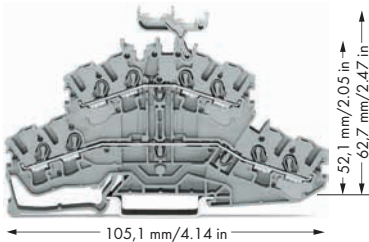

Item No.	Pack. Unit	Item No.	Pack. Unit	Item No.	Pack. Unit
Through/through terminal block, with marker carrier, gray housing		Through/through terminal block, with marker carrier, blue housing		Ground conductor/through terminal block, with marker carrier, gray housing	
○ L/L 2002-2431	50	● N/N 2002-2434 ④	50	○ PE/N 2002-2447	50
○ N/L 2002-2432	50			○ PE/L 2002-2457	50
○ L/N 2002-2433	50				
Through/through terminal block, without marker carrier, gray housing		Through/through terminal block, without marker carrier, blue housing		Ground conductor/through terminal block, without marker carrier, gray housing	
○ L/L 2002-2401	50	● N/N 2002-2404 ④	50	○ PE/N 2002-2417	50
○ N/L 2002-2402	50			○ PE/L 2002-2427	50
○ L/N 2002-2403	50				
Ex Approvals are pending					

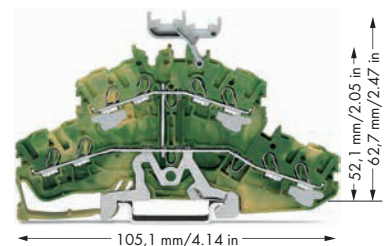
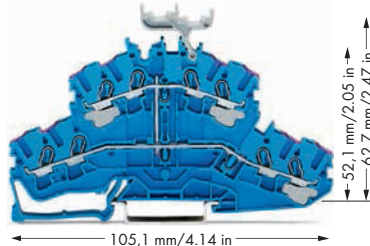
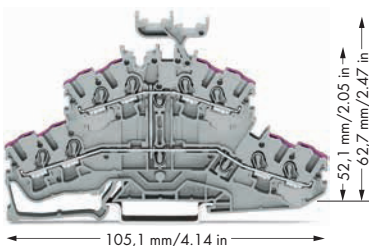

Item No.	Pack. Unit	Item No.	Pack. Unit	Item No.	Pack. Unit
8-conductor through terminal block, with marker carrier, internal commoning, conductor entry position colored in violet, gray housing		8-conductor through terminal block, with marker carrier, internal commoning, conductor entry position colored in violet, blue housing		8-conductor ground terminal block, with marker carrier, internal commoning, green-yellow housing	
○ L 2002-2438	50	● N 2002-2439 ④	50	● PE 2002-2437	50
8-conductor through terminal block, without marker carrier, internal commoning, conductor entry position colored in violet, gray housing		8-conductor through terminal block, without marker carrier, internal commoning, conductor entry position colored in violet, blue housing		8-conductor ground terminal block, without marker carrier, internal commoning, green-yellow housing	
○ L 2002-2408	50	● N 2002-2409 ④	50	● PE 2002-2407	50

0.25 - 2.5 (4) mm² ① | AWG 22 - 12
 800 V/8 kV/3 ②
 I_N 24 A (28 A)

Terminal block width 5.2 mm / 0.205 in
 10 - 12 mm / 0.43 in ③

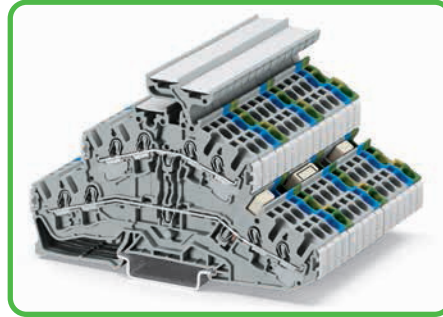
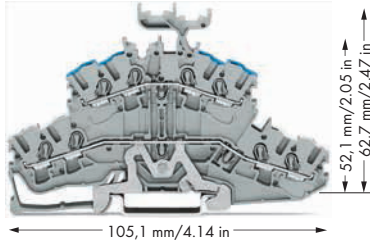



Double-deck terminal block assembly

- ① Conductor sizes: 0.25 mm² - 4 mm² "s + f-st";
 Push-in conductor sizes: 0.75 mm² - 4 mm² "s"
 and 0.75 mm² - 2.5 mm²
 "insulated ferrule, 12 mm"
- ② 800 V = rated voltage
 8 kV = rated surge voltage
 3 = pollution degree
 (see Section 14)
- ③ Strip length, see packaging or instructions.
- ④ Suitable for Ex i applications
- ⑤ See application notes for:
 Colored push-in type jumper bars, page 101
 Vertical jumper, page 105

Item No.	Pack. Unit	2002 Series Accessories	
Shield conductor/through terminal block, with marker carrier, gray housing		Appropriate marking systems: WMB/Marking strips/WMB Inline (see Section 13)	
Shield/N 2002-2448	50	End and intermediate plate, 0.8 mm thick orange 2002-2492 100 (4x25)	Test plug adapter, for 4 mm Ø test plug gray 2009-174 100 (4x25)
Shield/L 2002-2458	50	Double-deck marker carrier, pivoting gray 2002-121 50 (2x25)	Banana plug, for socket 4 mm Ø, color mixed 215-111 50
Shield conductor/through terminal block, without marker carrier, gray housing		Insulation stop, 5 pcs/strip, 0.25 - 0.5 mm ² light gray 2002-171 200 (8x25)	Testing tap, for max. 2.5 mm ² gray 2009-182 100 (4x25)
Shield/N 2002-2418	50	Insulation stop, 5 pcs/strip, 0.75 - 1 mm ² dark gray 2002-172 200 (8x25)	WMB Multi marking system, 10 strips with 10 markers per card, stretchable 5 - 5.2 mm plain 793-5501 5
Shield/L 2002-2428	50	Push-in type jumper bar, insulated, I _N 25 A, light gray ⑤ 2-way 2002-402 200 (8x25) 3-way 2002-403 200 (8x25) 4-way 2002-404 200 (8x25) 5-way 2002-405 100 (4x25) 6-way 2002-406 100 (4x25) 7-way 2002-407 100 (4x25) 8-way 2002-408 100 (4x25) 9-way 2002-409 100 (4x25) 10-way 2002-410 100 (4x25)	WMB Multi marking system, plain, 10 strips with 10 markers per card, stretchable 5 - 5.2 mm yellow 793-5501/000-002 red 793-5501/000-005 blue 793-5501/000-006 gray 793-5501/000-007 orange 793-5501/000-012 light green 793-5501/000-017 green 793-5501/000-023 violet 793-5501/000-024 5
		Push-in type jumper bar, insulated, I _N 25 A, light gray from 1 to 3 2002-433 200 (8x25) from 1 to 4 2002-434 200 (8x25) from 1 to 5 2002-435 100 (4x25) from 1 to 6 2002-436 100 (4x25) from 1 to 7 2002-437 100 (4x25) from 1 to 8 2002-438 100 (4x25) from 1 to 9 2002-439 100 (4x25) from 1 to 10 2002-440 100 (4x25)	WMB Inline, plain, stretchable 5 - 5.2 mm, 1,500 WMB markers, 5 mm, on roll white 2009-115 1
		Double-deck vertical jumper, insulated, I _N 24 A ⑤ light gray 2002-492 100 (4x25) orange 2002-492/000-012	Marking strip, plain, 11 mm wide, 50 m roll white 2009-110 1
		Protective warning marker, with high-voltage symbol, black, for 5 terminal blocks yellow 2002-115 100 (4x25)	TOPJOB®S group marker carrier, snap-on type for jumper slot, 5 mm wide gray 2009-191 50 (2x25)

TOPJOB® S Double-Deck Terminal Blocks 2.5 (4) mm² 2002 Series

<p>0.25 - 2.5 (4) mm² ① AWG 22 - 12 500 V/6 kV/3 ② I_N 24 A (28 A)</p> <p>Terminal block width 5.2 mm / 0.205 in  10 - 12 mm / 0.43 in ③</p>	<p>0.25 - 2.5 (4) mm² ① AWG 22 - 12 500 V/6 kV/3 ② I_N 24 A (28 A)</p> <p>Terminal block width 5.2 mm / 0.205 in  10 - 12 mm / 0.43 in ③</p>	<p>0.25 - 2.5 (4) mm² ① AWG 22 - 12 500 V/6 kV/3 ② I_N 24 A (28 A)</p> <p>Terminal block width 5.2 mm / 0.205 in  10 - 12 mm / 0.43 in ③</p>
--	---	---

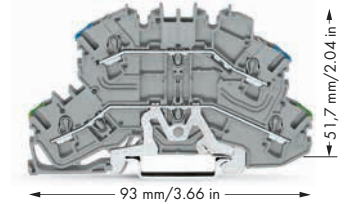
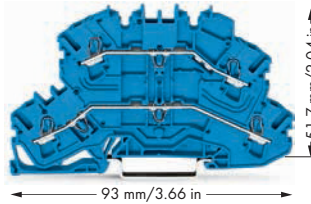
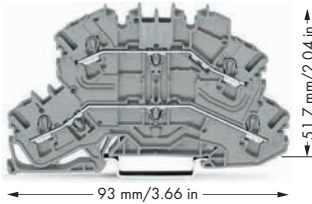

Item No.	Pack. Unit	Item No.	Pack. Unit	Item No.	Pack. Unit
Through/through terminal block, same profile as double-deck disconnect terminal block without marker carrier, gray housing <input type="radio"/> L/L 2002-2601 50 <input type="radio"/> N/L 2002-2602 50 <input type="radio"/> L/N 2002-2603 50		Through/through terminal block, same profile as double-deck disconnect terminal block without marker carrier, blue housing <input checked="" type="radio"/> N/N 2002-2604 ④ 50		Ground conductor/through terminal block, same profile as double-deck disconnect terminal block without marker carrier, gray housing <input type="radio"/> PE/N 2002-2647 50 <input type="radio"/> PE/L 2002-2657 50	
Other terminal blocks with the same profile: Carrier 2002-2661 Page 36 Disconnect 2002-2671 Page 36 Fuse 2002-2611 Page 37					

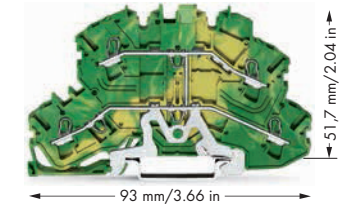
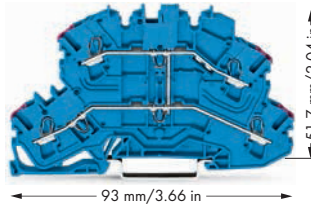
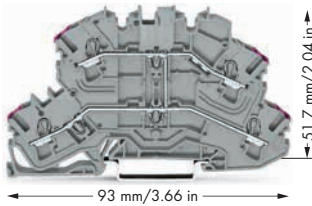

Item No.	Pack. Unit	Item No.	Pack. Unit	Item No.	Pack. Unit
4-conductor through terminal block, same profile as double-deck disconnect terminal block, without marker carrier, internal commoning, conductor entry position colored in violet, gray housing <input type="radio"/> L 2002-2608 50		4-conductor through terminal block, same profile as double-deck disconnect terminal block, without marker carrier, internal commoning, conductor entry position colored in violet, blue housing <input checked="" type="radio"/> N 2002-2609 ④ 50		Through/through terminal block, same profile as double-deck disconnect terminal block without marker carrier, internal commoning, green-yellow housing <input checked="" type="radio"/> PE 2002-2607 50	

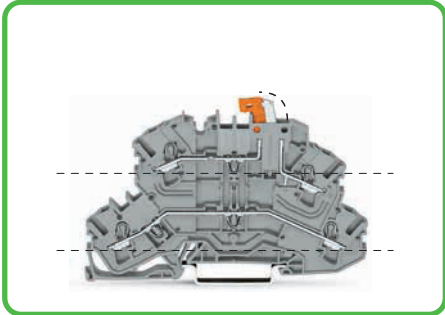

Multifunctional terminal blocks:
The double-deck disconnect terminal block with movable knife disconnect (2002-2671) can be used as through terminal block on the lower deck and as disconnect terminal block on the upper deck.

Besides disconnection and measurement, the **2002-2667 double-deck carrier terminal block** also provides ground conductor functionality.

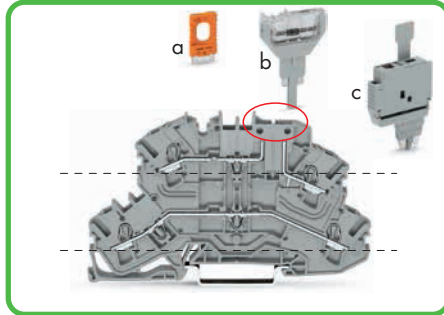

The associated **carrier terminal block (2002-2661)** has the same design as the disconnect terminal block. However, disconnect plugs (a: 2002-401), pluggable diode (b: 2002-800/1000-411) and LED modules (not shown here, 2002-800/1000-541) or fuse plugs (c: 2004-911) can alternatively be used here.

- ❶ Conductor sizes: 0.25 mm² - 4 mm² "s + f-st";
Push-in conductor sizes: 0.75 mm² - 4 mm² "s"
and 0.75 mm² - 2.5 mm²
"insulated ferrule, 12 mm"
- ❷ 500 V = rated voltage
6 kV = rated surge voltage
3 = pollution degree
(see Section 14)
- ❸ Strip length, see packaging or instructions.
- ❹ Suitable for Ex i applications
- ❺ See application notes for:
Colored push-in type jumper bars, page 101
Vertical jumper, page 105

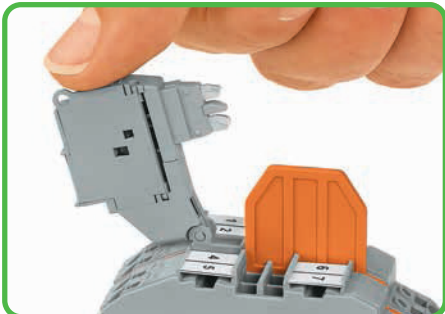

The **double-deck fuse disconnect terminal block with pivoting fuse holder (2002-2611, gray)** is compatible with disconnect, carrier, through and ground conductor terminal blocks. The fuse holder is also available with a blown fuse LED indicator.
(e.g., 2002-2611/1000-541 for 12-30 V)

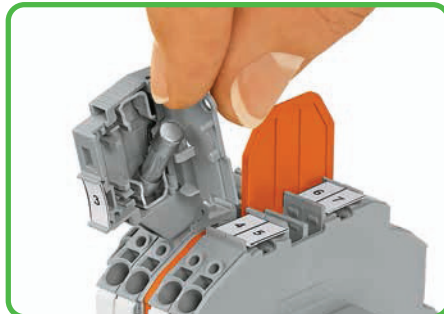

An **end plate for fuse terminal blocks (shown in orange, 2002-1092)** is used for additional protection, preventing the fuse shaft from being opened. The fuse cannot be replaced until disconnecting the fuse holder from the power supply.

2002 Series Accessories

Appropriate marking systems: WMB/Marking strips/WMB Inline

End and intermediate plate,			
	1 mm thick		
	orange	2002-2692	100 (4x25)
	gray	2002-2691	100 (4x25)

Double-deck marker carrier,			
	pivoting		
	gray	2002-121	50 (2x25)

Insulation stop,			
	5 pcs/strip,		
	0.25 - 0.5 mm ²		
	light gray	2002-171	200 (8x25)

Insulation stop,			
	5 pcs/strip,		
	0.75 - 1 mm ²		
	dark gray	2002-172	200 (8x25)

Push-in type jumper bar, insulated,			
❺	I _N 25 A,		
	light gray		
	2-way	2002-402	200 (8x25)
	3-way	2002-403	200 (8x25)
	4-way	2002-404	200 (8x25)
	5-way	2002-405	100 (4x25)
	6-way	2002-406	100 (4x25)
	7-way	2002-407	100 (4x25)
	8-way	2002-408	100 (4x25)
	9-way	2002-409	100 (4x25)
	10-way	2002-410	100 (4x25)

Push-in type jumper bar, insulated,			
	I _N 25 A,		
	light gray		
	from 1 to 3	2002-433	200 (8x25)
	from 1 to 4	2002-434	200 (8x25)
	from 1 to 5	2002-435	100 (4x25)
	from 1 to 6	2002-436	100 (4x25)
	from 1 to 7	2002-437	100 (4x25)
	from 1 to 8	2002-438	100 (4x25)
	from 1 to 9	2002-439	100 (4x25)
	from 1 to 10	2002-440	100 (4x25)

Double-deck vertical jumper, insulated,			
❺	I _N 24 A		
	light gray	2002-492	100 (4x25)
	orange	2002-492/000-012	

Adjacent jumper for continuous commoning, insulated,			
	I _N 25 A,		
	light gray		
	2-way	2002-400	100 (4x25)

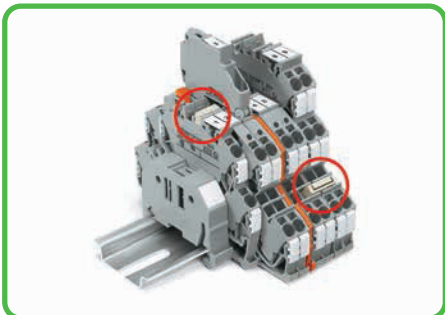

Same profile allows for commoning with TOPJOB® S double-deck terminal blocks (upper deck) and with triple-deck terminal blocks (lower deck).

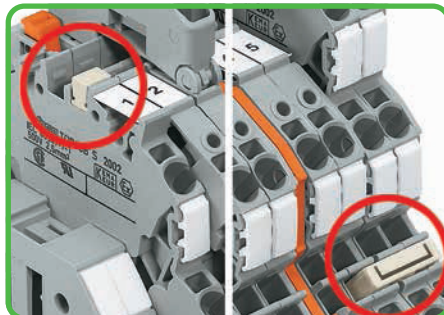

Left picture - Vertical jumper (2002-492)
Right picture - Push-in type jumper bar for 2002 Series

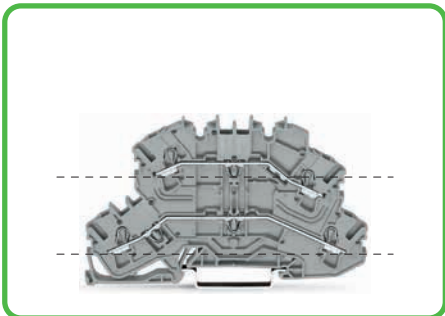

The **through terminal block (2002-2601)** features two independent current bars on both lower and upper deck, sharing the same profile as the disconnect terminal block. Commoning is also possible for these terminal blocks using the double-deck vertical jumper (2002-492).

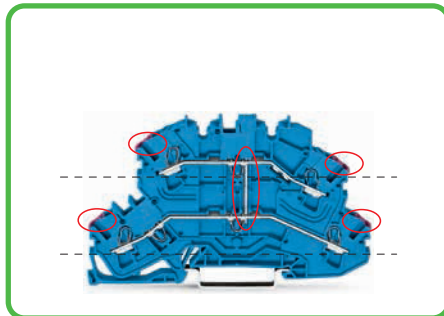

The **4-conductor through terminal block (2002-2609)** with internal commoning can be immediately identified via violet-colored conductor entry.

TOPJOB® S Double-Deck Disconnect Terminal Blocks and Carrier Terminal Blocks 2.5 (4) mm², 2002 Series



0.25 - 2.5 (4) mm ² ① AWG 22 - 12 400 V/6 kV/3 ② I _N 16 A Terminal block width 5.2 mm / 0.205 in 10 - 12 mm / 0.43 in ③	0.25 - 2.5 (4) mm ² ① AWG 22 - 12 400 V/6 kV/3 ② I _N 16 A Terminal block width 5.2 mm / 0.205 in 10 - 12 mm / 0.43 in ③
---	---

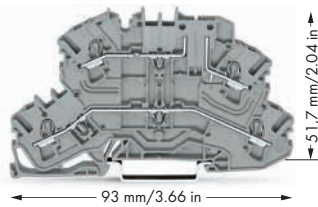
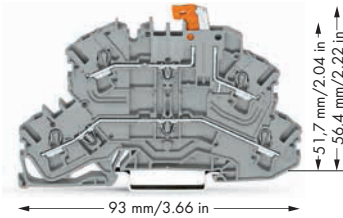

- ① Conductor sizes: 0.25 mm² - 4 mm² "s + f-st"; Push-in conductor sizes: 0.75 mm² - 4 mm² "s" and 0.75 mm² - 2.5 mm² "insulated ferrule, 12 mm"
- ② 500 V = rated voltage
6 kV = rated surge voltage
3 = pollution degree
(see Section 14)
- ③ Strip length, see packaging or instructions.
- ④ See application notes for:
Colored push-in type jumper bars, page 101
Vertical jumper, page 105

Item No.	Pack. Unit	Item No.	Pack. Unit
Double-deck disconnect terminal block, with movable knife disconnect, gray housing		Double-deck carrier terminal block, upper deck carrier, gray housing	
○ L/L 2002-2671	50	○ L/L 2002-2661	50
○ N/L 2002-2672	50	○ N/L 2002-2662	50

2002 Series Accessories

Appropriate marking systems: WMB/Marking strips/WMB Inline

End and intermediate plate, 1 mm thick			
	orange	2002-2692	100 (4x25)
	gray	2002-2691	100 (4x25)

Double-deck marker carrier,			
	pivoting		
	gray	2002-121	50 (2x25)

Insulation stop, 5 pcs/strip, 0.25 - 0.5 mm ²			
	light gray	2002-171	200 (8x25)

Insulation stop, 5 pcs/strip, 0.75 - 1 mm ²			
	dark gray	2002-172	200 (8x25)

Push-in type jumper bar, insulated,			
	light gray		
	I _N 25 A,		
	2-way	2002-402	200 (8x25)
	3-way	2002-403	200 (8x25)
	4-way	2002-404	200 (8x25)
	5-way	2002-405	100 (4x25)
	6-way	2002-406	100 (4x25)
	7-way	2002-407	100 (4x25)
	8-way	2002-408	100 (4x25)
	9-way	2002-409	100 (4x25)
	10-way	2002-410	100 (4x25)

Push-in type jumper bar, insulated,			
	light gray		
	I _N 25 A,		
	from 1 to 3	2002-433	200 (8x25)
	from 1 to 4	2002-434	200 (8x25)
	from 1 to 5	2002-435	100 (4x25)
	from 1 to 6	2002-436	100 (4x25)
	from 1 to 7	2002-437	100 (4x25)
	from 1 to 8	2002-438	100 (4x25)
	from 1 to 9	2002-439	100 (4x25)
	from 1 to 10	2002-440	100 (4x25)

Double-deck vertical jumper, insulated,			
	light gray	2002-492	100 (4x25)
	orange	2002-492/000-012	

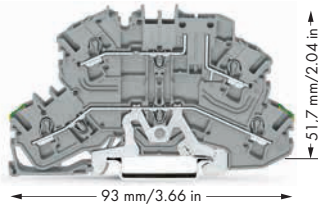

Adjacent jumper for continuous commoning, insulated,			
	light gray		
	I _N 25 A,		
	2-way	2002-400	100 (4x25)

Item No.	Pack. Unit
Double-deck carrier terminal block, upper deck carrier, gray housing	
○ PE/L 2002-2667	50



TOPJOB® S

Double-Deck Fuse Disconnect Terminal Blocks with Pivoting Fuse Holder 2.5 (4) mm², 2002 Series

0.25 - 2.5 (4) mm ² ① AWG 22 - 12 250 V/6 kV/3 ② I _N 6.3 A Terminal block width 6.2 mm / 0.244 in  10 - 12 mm / 0.43 in ③	0.25 - 2.5 (4) mm ² ① AWG 22 - 12 250 V/6 kV/3 ② I _N 6.3 A Terminal block width 6.2 mm / 0.244 in  10 - 12 mm / 0.43 in ③
--	--

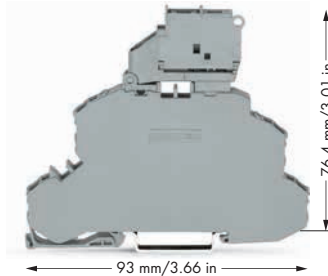
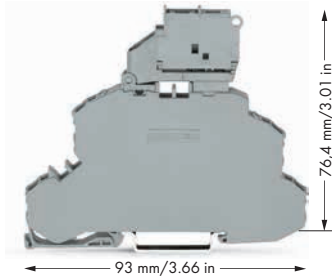

- ① Conductor sizes: 0.25 mm² - 4 mm² "s + f-st"; Push-in conductor sizes: 0.75 mm² - 4 mm² "s" and 0.75 mm² - 2.5 mm² "insulated ferrule, 12 mm"
- ② 250 V = rated voltage
6 kV = rated surge voltage
3 = pollution degree
(see Section 14)
- ③ Strip length, see packaging or instructions.
- ④ See application notes for:
Vertical jumper, page 105
- ⑤ Protective warning marker and insulation stop must be applied individually.
- ⑥ Due to the 6.2 mm width of fuse terminal blocks with pivoting fuse holder, 2004 Series jumpers must be used.



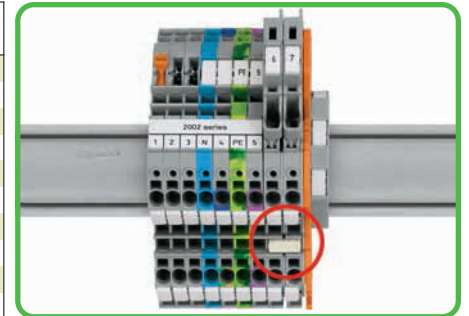









Item No.	Pack. Unit	Item No.	Pack. Unit
Double-deck fuse disconnect terminal block with pivoting fuse holder, Through/fuse terminal block, for miniature fuses 5 x 20 mm, without blown fuse indication Nominal voltage and current are given by the fuse.		Double-deck fuse disconnect terminal block with pivoting fuse holder, Through/fuse terminal block, for miniature fuses 5 x 20 mm, with blown fuse indication by LED, gray Nominal voltage and current are given by the LED or fuse. Leakage current in case of blown fuse: LED 2mA	
○ L/L	2002-2611	25	○ 12 - 30 V
○ N/L	2002-2612	25	○ 30 - 65 V
			○ 230 V
			2002-2611/1000-541 25
			2002-2611/1000-542 25
			2002-2611/1000-836 25



A spacer plate is supplied with all 6.2 mm wide fuse terminal blocks.
Due to the 6.2 mm width of fuse terminal blocks with pivoting fuse holder, 2004 Series jumpers must be used.

2002 Series Accessories

Appropriate marking systems: WMB/Marking strips/WMB Inline
(see Section 13)

End and intermediate plate, 1 mm thick  orange 2002-2692 100 (4x25)  gray 2002-2691 100 (4x25)	End plate for fuse terminal blocks, 2 mm thick  orange 2002-1092 100 (4x25)  gray 2002-1091 100 (4x25)
Push-in type jumper bar, insulated, I _N 32 A, light gray  2-way 2004-402 200 (8x25) 3-way 2004-403 200 (8x25) 4-way 2004-404 100 (4x25) 5-way 2004-405 100 (4x25) 6-way 2004-406 100 (4x25) 7-way 2004-407 100 (4x25) 8-way 2004-408 100 (4x25) 9-way 2004-409 100 (4x25) 10-way 2004-410 100 (4x25)	Insulation stop, ⑤ 5 pcs/strip, 0.25 - 0.5 mm ²  light gray 2002-171 200 (8x25) Insulation stop, 5 pcs/strip, 0.75 - 1 mm ²  dark gray 2002-172 200 (8x25)
Push-in type jumper bar, insulated, I _N 32 A, light gray  from 1 to 3 2004-433 200 (8x25) from 1 to 4 2004-434 200 (8x25) from 1 to 5 2004-435 100 (4x25) from 1 to 6 2004-436 100 (4x25) from 1 to 7 2004-437 100 (4x25) from 1 to 8 2004-438 100 (4x25) from 1 to 9 2004-439 100 (4x25) from 1 to 10 2004-440 100 (4x25)	Protective warning marker, ⑤ with high-voltage symbol, black, for 5 terminal blocks  yellow 2002-115 100 (4x25) Test plug,  with 500 mm cable, 2 mm Ø red 210-136 50 Test plug,  with 500 mm cable, 2.3 mm Ø yellow 210-137 50 Marking strip, plain,  11 mm wide, 50 m roll white 2009-110 1
Double-deck vertical jumper, insulated, ④ I _N 24 A light gray 2002-492 100 (4x25) orange 2002-492/000-012	

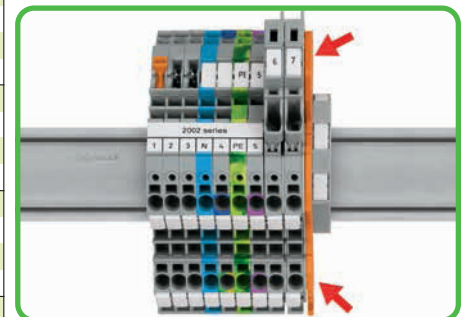



Additionally, an end plate for fuse terminal blocks (e.g., 2002-1092, orange) must be used at the end of an assembly or if there is no adjacent fuse terminal block.

TOPJOB® S

Triple-Deck Terminal Blocks 2.5 (4) mm²

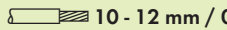
2002 Series

<p>0.25 - 2.5 (4) mm² ① AWG 22 - 12 500 V/6 kV/3 ② I_N 24 A (28 A)</p> <p>Terminal block width 5.2 mm / 0.205 in  10 - 12 mm / 0.43 in ③</p>	<p>0.25 - 2.5 (4) mm² ① AWG 22 - 12 500 V/6 kV/3 ② I_N 24 A (28 A) 600 V, 20 A ③</p> <p>Terminal block width 5.2 mm / 0.205 in  10 - 12 mm / 0.43 in ③</p>	<p>0.25 - 2.5 (4) mm² ① AWG 22 - 12 500 V/6 kV/3 ② I_N 24 A (28 A)</p> <p>Terminal block width 5.2 mm / 0.205 in  10 - 12 mm / 0.43 in ③</p>
--	---	---

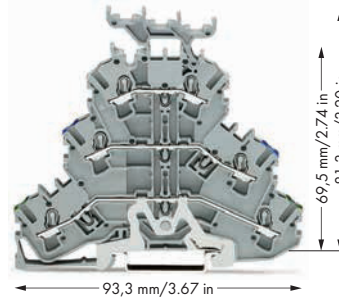
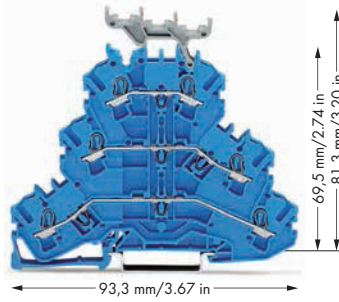
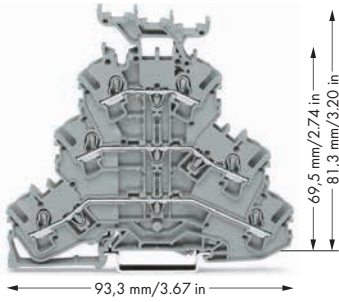

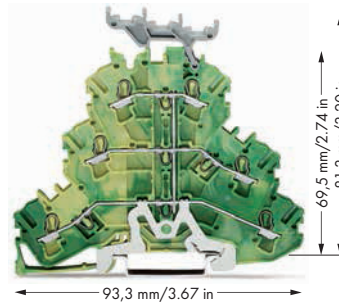
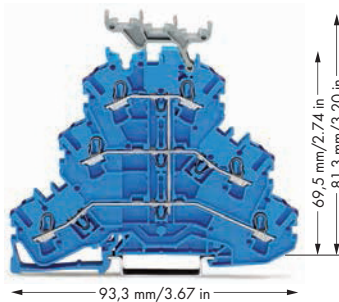
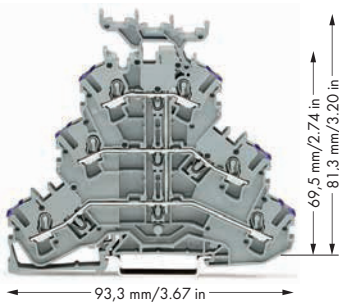

Item No.	Pack. Unit	Item No.	Pack. Unit	Item No.	Pack. Unit
Through/through/through terminal block, with marker carrier, gray housing		Through/through/through terminal block, with marker carrier, blue housing		Ground conductor/through/through terminal block, with marker carrier, gray housing	
○ L/L/L ⑤	2002-3231 ⑤ 50	● N/N/N ⑤	2002-3234 ④ ⑤ 50	○ PE/N/L ⑤	2002-3247 ⑤ 50
○ L/L/N ⑤	2002-3233 ⑤ 50			○ PE/L/L ⑤	2002-3257 ⑤ 50
Through/through/through terminal block, without marker carrier, gray housing		Through/through/through terminal block, without marker carrier, blue housing		Ground conductor/through/through terminal block, without marker carrier, gray housing	
○ L/L/L ⑤	2002-3201 ⑤ 50	● N/N/N ⑤	2002-3204 ④ ⑤ 50	○ PE/N/L ⑤	2002-3217 ⑤ 50
○ L/L/N ⑤	2002-3203 ⑤ 50			○ PE/L/L ⑤	2002-3227 ⑤ 50
Other terminal blocks with the same profile:					
Diode	2002-3211/1000-410	Page 88			
LED	2002-3221/1000-434	Page 88			



Item No.	Pack. Unit	Item No.	Pack. Unit	Item No.	Pack. Unit
6-conductor through terminal block, with marker carrier, internal commoning, conductor entry position colored in violet, gray housing		6-conductor through terminal block, with marker carrier, internal commoning, conductor entry position colored in violet, blue housing		6-conductor ground terminal block, with marker carrier, internal commoning, green-yellow housing	
○ L ⑤	2002-3238 ⑤ 50	● N ⑤	2002-3239 ④ ⑤ 50	● PE ⑤	2002-3237 ⑤ 50
6-conductor through terminal block, without marker carrier, internal commoning, conductor entry position colored in violet, gray housing		6-conductor through terminal block, without marker carrier, internal commoning, conductor entry position colored in violet, blue housing		6-conductor ground terminal block, without marker carrier, internal commoning, green-yellow housing	
○ L ⑤	2002-3208 ⑤ 50	● N ⑤	2002-3209 ④ ⑤ 50	● PE ⑤	2002-3207 ⑤ 50

TOPJOB® S

Quadruple-Deck, Rail-Mounted Terminal Blocks or Rail-Mounted Terminal Blocks for Wiring of Electric Motors, 2002 Series

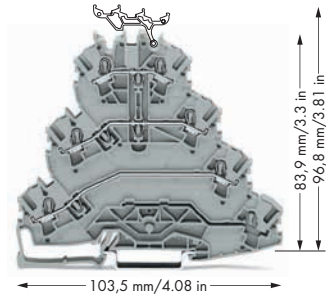
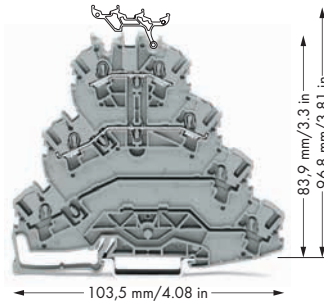
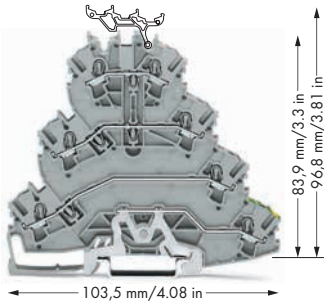

<p>0.25 - 2.5 (4) mm² ① AWG 22 - 12 800 V/8 kV/3 ② I_N 20 A (25 A)</p> <p>Terminal block width 5.2 mm / 0.205 in  10 - 12 mm / 0.43 in ③</p>	<p>0.25 - 2.5 (4) mm² ① AWG 22 - 12 800 V/8 kV/3 ② I_N 20 A (25 A)</p> <p>Terminal block width 5.2 mm / 0.205 in  10 - 12 mm / 0.43 in ③</p>	<p>0.25 - 2.5 (4) mm² ① AWG 22 - 12 800 V/8 kV/3 ② I_N 20 A (25 A)</p> <p>Terminal block width 5.2 mm / 0.205 in  10 - 12 mm / 0.43 in ③</p>
--	---	---



Item No.	Pack. Unit	Item No.	Pack. Unit	Item No.	Pack. Unit
Quadruple-deck, rail-mounted terminal block or Rail-mounted terminal block for wiring of electric motors, without marker carrier, gray		Quadruple-deck, rail-mounted terminal block or Rail-mounted terminal block for wiring of electric motors, without marker carrier, gray		Quadruple-deck, rail-mounted terminal block or Rail-mounted terminal block for wiring of electric motors, without marker carrier, gray	
○ L1 - L2 - L3 - PE 2002-4127	25	○ L1 - L2 2002-4111	25	○ L1 - L2 - L3 2002-4101	25
Quadruple-deck, rail-mounted terminal block or Rail-mounted terminal block for wiring of electric motors, with marker carrier, gray		Quadruple-deck, rail-mounted terminal block or Rail-mounted terminal block for wiring of electric motors, with marker carrier, gray		Quadruple-deck, rail-mounted terminal block or Rail-mounted terminal block for wiring of electric motors, with marker carrier, gray	
○ L1 - L2 - L3 - PE 2002-4157	25	○ L1 - L2 2002-4141	25	○ L1 - L2 - L3 2002-4131	25

2002 Series Accessories

Appropriate marking systems: WMB/Marking strips/WMB Inline
(see Section 13)

<p>End and intermediate plate, 1 mm thick</p> <p> orange 2002-4192 100 (4x25) gray 2002-4191 100 (4x25)</p>	<p>Protective warning marker, with high-voltage symbol, black, for 5 terminal blocks yellow 2002-115 100 (4x25)</p>	<p>Staggered jumper, ④ insulated, I_N 25 A, light gray</p> <p>2-way 2002-472 100 (4x25) 3-way 2002-473 100 (4x25) 4-way 2002-474 100 (4x25) 5-way 2002-475 50 (2x25) 6-way 2002-476 50 (2x25) 7-way 2002-477 50 (2x25) 8-way 2002-478 50 (2x25) 9-way 2002-479 50 (2x25) 10-way 2002-480 50 (2x25) 11-way 2002-481 50 (2x25) 12-way 2002-482 50 (2x25)</p>
<p>Insulation stop, 5 pcs/strip, 0.25 - 0.5 mm² light gray 2002-171 200 (8x25)</p>	<p>Lockout cap, for conductor entry hole and operating slot</p> <p> orange 2002-192 25 gray 2002-191 25 blue 2002-194 25</p>	
<p>Insulation stop, 5 pcs/strip, 0.75 - 1 mm² dark gray 2002-172 200 (8x25)</p>		
<p>Push-in type jumper bar, insulated, ④ I_N 25 A, light gray</p> <p>2-way 2002-402 200 (8x25) 3-way 2002-403 200 (8x25) 4-way 2002-404 200 (8x25) 5-way 2002-405 100 (4x25) 6-way 2002-406 100 (4x25) 7-way 2002-407 100 (4x25) 8-way 2002-408 100 (4x25) 9-way 2002-409 100 (4x25) 10-way 2002-410 100 (4x25)</p>	<p>Push-in type jumper bar, insulated, I_N 25 A, light gray</p> <p>from 1 to 3 2002-433 200 (8x25) from 1 to 4 2002-434 200 (8x25) from 1 to 5 2002-435 100 (4x25) from 1 to 6 2002-436 100 (4x25) from 1 to 7 2002-437 100 (4x25) from 1 to 8 2002-438 100 (4x25) from 1 to 9 2002-439 100 (4x25) from 1 to 10 2002-440 100 (4x25)</p>	
<p>Star point jumper, insulated, ④ I_N = I_N terminal block, light gray 1-3-5 2002-405/011-000 100 (4x25)</p>	<p>Adjacent jumper for continuous commoning, insulated, ④ I_N 25 A, light gray 2-way 2002-400 100 (4x25)</p>	<p>Push-in type wire jumper, ④ insulated, I_N 18 A, wire size 1.5 mm²</p> <p>L = 60 mm 2009-412 100 (10x10) L = 110 mm 2009-414 100 (10x10) L = 250 mm 2009-416 100 (10x10)</p>
<p>Delta jumper, insulated, ④ I_N = I_N terminal block, light gray 1-2 3-4 5-6 2002-406/020-000 100 (4x25)</p>	<p>Triple-deck marker carrier, pivoting gray 2002-131 50 (2x25)</p>	<p>WMB Inline, plain, stretchable 5 - 5.2 mm, 1,500 WMB markers, 5 mm, on roll white 2009-115 1</p>
		<p>Marking strip, plain, 11 mm wide, 50 m roll white 2009-110 1</p>

Certification organizations can be found in the overview on pages 622 and 623.

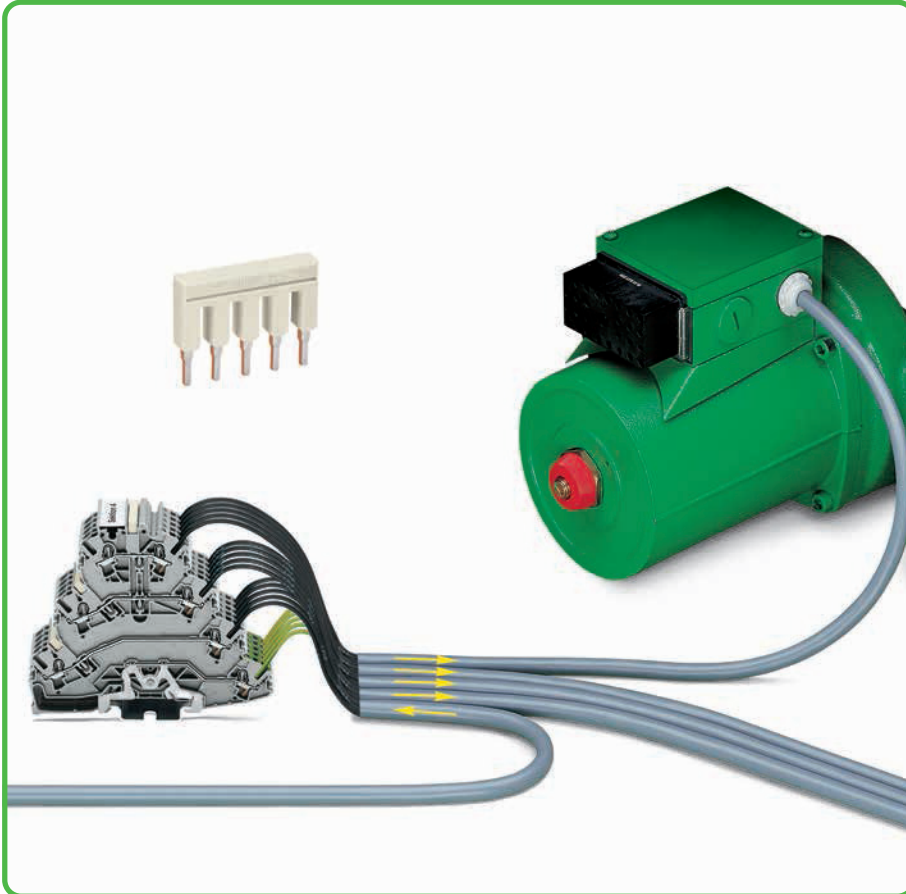

- 1 Conductor sizes: 0.25 mm² - 4 mm² "s + f-st";
Push-in conductor sizes: 0.75 mm² - 4 mm² "s"
and 0.75 mm² - 2.5 mm²
"insulated ferrule, 12 mm"
- 2 800 V = rated voltage
8 kV = rated surge voltage
3 = pollution degree
(see Section 14)
- 3 Strip length, see packaging or instructions.
- 4 See application notes for:
Colored push-in type jumper bars, page 101
Staggered jumper, page 104
Delta jumper, page 104
Star point jumper, page 101
Adjacent jumper for continuous commoning,
page 101
Push-in type wire jumper, page 102
TOPJOB®S connector, page 96
TOPJOB®S L-type test plug module, page 100
Marker carrier, page 109

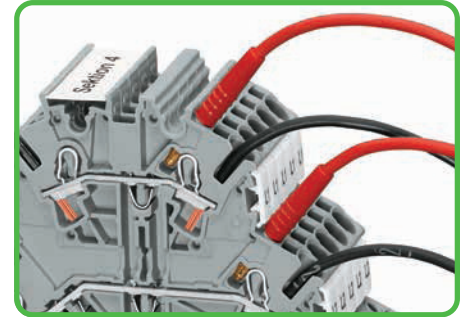

Testing with test plug 2 mm Ø.

In addition to rail-mounted terminal blocks for electric motor wiring, new versions are now available.

- Terminal block **without** ground contact and only 2 potentials.
Especially for additional functions such as engine brakes or temperature probes. Having the same shape, this type can be put next to the appropriate terminal block for electric motor wiring without using intermediate plates. That makes the rail assembly clearer and wiring is easier. This also prevents wiring errors as no conductor entry is unused.
- Terminal block **without** ground contact and with only 3 potentials.
Clearly designated clamping units is the primary advantage to this terminal block design. When using devices with protective insulation for example, there are no open ground clamping units that could create confusion.

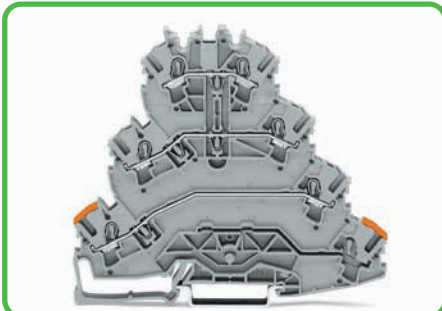

Lockout cap for conductor entry hole and operating slot

Locking out conductor entry holes and operating slots to create spacer housings for rail-mounted terminal blocks for electric motor wiring.



Compact design:
3 phases and ground conductor in one terminal block.



Marking clamping units with WMB Multi marking system.
Group marking with marking strips.

TOPJOB® S Double-Deck Disconnect Terminal Blocks for Test and Measurement 2.5 (4) mm², 2002 Series

0.25 - 2.5 (4) mm ² ① 400 V/6 kV/3 ② I _N 16 A Terminal block width 5.2 mm / 0.205 in 10 - 12 mm / 0.43 in ③	AWG 22 - 12 300 V, 15 A ④ 300 V, 15 A ⑤	0.25 - 2.5 (4) mm ² ① 400 V/6 kV/3 ② I _N 16 A Terminal block width 5.2 mm / 0.205 in 10 - 12 mm / 0.43 in ③	AWG 22 - 12 300 V, 15 A ④ 300 V, 15 A ⑤	0.25 - 2.5 (4) mm ² ① 400 V/6 kV/3 ② I _N 16 A Terminal block width 5.2 mm / 0.205 in 10 - 12 mm / 0.43 in ③	AWG 22 - 12 300 V, 15 A ④ 300 V, 15 A ⑤
---	---	---	---	---	---

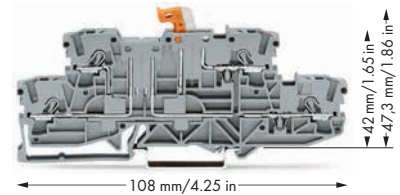
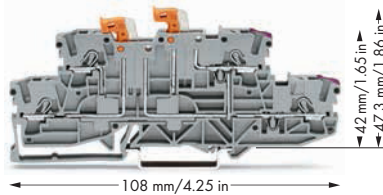
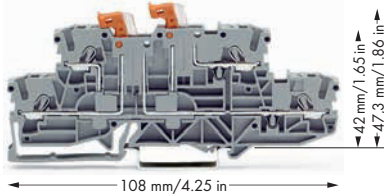

Item No.	Pack. Unit	Item No.	Pack. Unit	Item No.	Pack. Unit
Double-deck, double-disconnect terminal block, with 2 pivoting knife disconnects, gray housing		Double-deck, double-disconnect terminal block, with 2 pivoting knife disconnects, lower and upper decks internally commoned on right side and with violet marking, gray housing		Double-deck disconnect terminal block, with pivoting knife disconnect, same profile as double-deck, double-disconnect terminal block, gray housing	
○ L/L 2002-2951	50	○ L/L 2002-2958	50	○ L/L 2002-2971	50
○ N/L 2002-2952	50			○ N/L 2002-2972	50
Double-deck, double-disconnect terminal block, with 2 pivoting knife disconnects, blue housing		Double-deck, double-disconnect terminal block, with 2 pivoting knife disconnects, lower and upper decks internally commoned on right side and with violet marking, blue housing		Double-deck disconnect terminal block, with pivoting knife disconnect, same profile as double-deck, double-disconnect terminal block, blue housing	
● N/N 2002-2954	50	● N/N 2002-2959	50	● N/N 2002-2974	50

2002 Series Accessories

Appropriate marking systems: WMB/Marking strips
(see Section 13)

End and intermediate plate, 1 mm thick orange 2002-2992 100 (4x25) gray 2002-2991 100 (4x25)	Push-in type jumper bar, insulated, I_N 25 A, light gray from 1 to 3 2002-433 200 (8x25) from 1 to 4 2002-434 200 (8x25) from 1 to 5 2002-435 100 (4x25) from 1 to 6 2002-436 100 (4x25) from 1 to 7 2002-437 100 (4x25) from 1 to 8 2002-438 100 (4x25) from 1 to 9 2002-439 100 (4x25) from 1 to 10 2002-440 100 (4x25)	Protective warning marker, with high-voltage symbol, black, for 5 terminal blocks yellow 2002-115 100 (4x25)
Insulation stop, 5 pcs/strip, 0.25 - 0.5 mm² light gray 2002-171 200 (8x25)		Modular TOPJOB®S connector, can be snapped together, for jumper contact slot gray 2002-511 100 (4x25)
Insulation stop, 5 pcs/strip, 0.75 - 1 mm² dark gray 2002-172 200 (8x25)		Spacer module, can be snapped together, e.g., for bridging commoned terminal blocks gray 2002-549 100 (4x25)
Push-in type jumper bar, insulated, I_N 25 A, light gray 2-way 2002-402 200 (8x25) 3-way 2002-403 200 (8x25) 4-way 2002-404 200 (8x25) 5-way 2002-405 100 (4x25) 6-way 2002-406 100 (4x25) 7-way 2002-407 100 (4x25) 8-way 2002-408 100 (4x25) 9-way 2002-409 100 (4x25) 10-way 2002-410 100 (4x25)	Staggered jumper, insulated, I_N 25 A, light gray 2-way 2002-472 100 (4x25) 3-way 2002-473 100 (4x25) 4-way 2002-474 100 (4x25) 5-way 2002-475 50 (2x25) 6-way 2002-476 50 (2x25) 7-way 2002-477 50 (2x25) 8-way 2002-478 50 (2x25) 9-way 2002-479 50 (2x25) 10-way 2002-480 50 (2x25) 11-way 2002-481 50 (2x25) 12-way 2002-482 50 (2x25)	End plate, for modular TOPJOB®S connectors, 1.5 mm thick gray 2002-541 100 (4x25)
Push-in type wire jumper, insulated, I_N 18 A, wire size 1.5 mm² L = 60 mm 2009-412 100 (10x10) L = 110 mm 2009-414 100 (10x10) L = 250 mm 2009-416 100 (10x10)	Adjacent jumper for continuous commoning, insulated, I_N 25 A, light gray 2-way 2002-400 100 (4x25)	Test plug, with 500 mm cable, 2 mm Ø red 210-136 50
		Test plug adapter, for 4 mm Ø test plug gray 2009-174 100 (4x25)
		Testing tap, for max. 2.5 mm² gray 2009-182 100 (4x25)
		Banana plug, for socket 4 mm Ø, color mixed 215-111 50

Double-Deck Disconnect Terminal Blocks with Pivoting Knife Disconnect

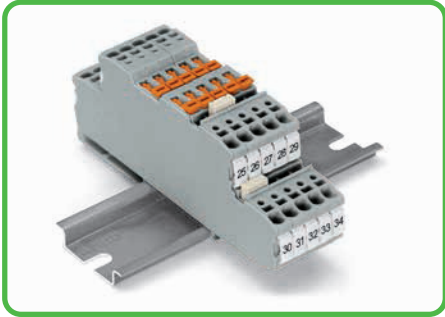

Terminal block assembly

- ❶ Conductor sizes: 0.25 mm² - 4 mm² "s + f-st";
Push-in conductor sizes: 0.75 mm² - 4 mm² "s"
and 0.75 mm² - 2.5 mm² "insulated ferrules, 12 mm"
- ❷ 400 V = rated voltage
6 kV = rated surge voltage
3 = pollution degree
(see Section 14)
- ❸ Strip length, see packaging or instructions.
- ❹ See application notes for:
Colored push-in type jumper bars, page 101
Staggered jumper, page 104
Delta jumper, page 104
Star point jumper, page 101
Adjacent jumper for continuous commoning, page 101
Push-in type wire jumper, page 102
TOPJOB®S connector, page 96
TOPJOB®S L-type test plug module, page 100

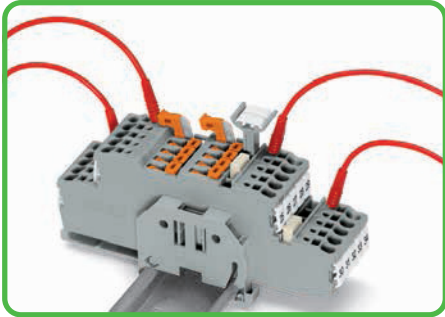

Testing with test plug 2 mm Ø.

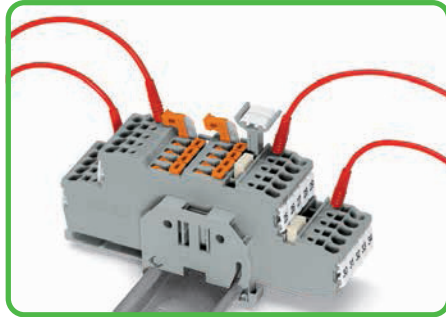

Group marker carrier accommodated in jumper contact slot.

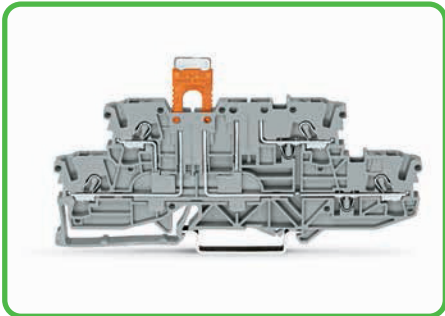



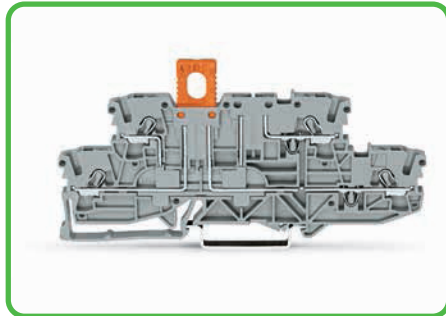



Carrier terminal block (2002-2941) with disconnect plug (2002-401) in parked position.



Carrier terminal block (2002-2941) with disconnect plug (2002-401) in operating position.

Accessories

WMB Multi marking system,		
	10 strips with 10 markers per card, stretchable 5 - 5.2 mm plain	793-5501 5
WMB Multi marking system, plain,		
	10 strips with 10 markers per card, stretchable 5 - 5.2 mm	
yellow	793-5501/000-002	
red	793-5501/000-005	
blue	793-5501/000-006	
gray	793-5501/000-007	
orange	793-5501/000-012	
light green	793-5501/000-017	
green	793-5501/000-023	
violet	793-5501/000-024	5
WMB Inline, plain,		
	stretchable 5 - 5.2 mm, 1,500 WMB markers, 5 mm, on roll white	2009-115 1
TOPJOB®S group marker carrier,		
	snap-on type for jumper slot, 5 mm wide	
gray	2009-191	50 (2x25)
Screwless end stop,		
	for DIN 35 rail, 6 mm wide	
gray	249-116	100 (4x25)
Screwless end stop,		
	for DIN 35 rail, 10 mm wide	
gray	249-117	50 (2x25)

TOPJOB® S

Disconnect Terminal Blocks for Test and Measurement, Through Terminal Blocks of Same Profile 2.5 (4) mm², 2002 Series

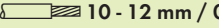
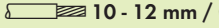
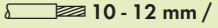
<p>0.25 - 2.5 (4) mm² ① AWG 22 - 12 400 V/6 kV/3 ② I_N 16 A</p> <p>Terminal block width 5.2 mm / 0.205 in  10 - 12 mm / 0.43 in ③</p>	<p>0.25 - 2.5 (4) mm² ① AWG 22 - 12 400 V/6 kV/3 ② I_N 16 A</p> <p>Terminal block width 5.2 mm / 0.205 in  10 - 12 mm / 0.43 in ③</p>	<p>0.25 - 2.5 (4) mm² ① AWG 22 - 12 400 V/6 kV/3 ② I_N 16 A</p> <p>Terminal block width 5.2 mm / 0.205 in  10 - 12 mm / 0.43 in ③</p>
---	--	--

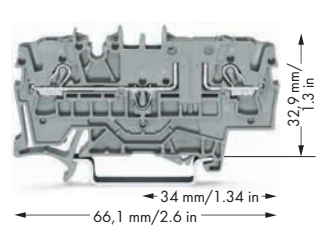
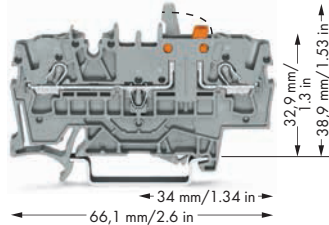
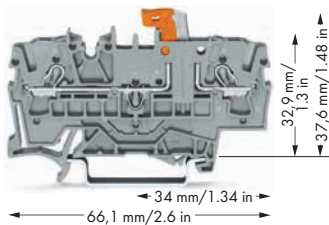

Item No.	Pack. Unit	Item No.	Pack. Unit	Item No.	Pack. Unit
2-conductor disconnect terminal block for test and measurement, with test point, orange disconnect link		2-conductor disconnect terminal block for test and measurement with mechanical interlock, with test point, orange disconnect link		2-conductor through terminal block, with test point, same profile as 2-conductor disconnect terminal block	
gray 2002-1671	50	gray 2002-1671/401-000	50	gray 2002-1601	50
blue 2002-1674	50	blue 2002-1674/401-000	50	blue 2002-1604	50
orange 2002-1672	50	orange 2002-1672/401-000	50	orange 2002-1602	50
				Other terminal blocks with the same profile:	
				Carrier 2002-1661	Page 76
				Fuse 2002-1681	Page 50

2002 Series Accessories

Appropriate marking systems: WMB/Marking strips/WMB Inline (see Section 13)

<p>End and intermediate plate, 1 mm thick</p> <p>orange 2002-1692 100 (4x25) gray 2002-1691 100 (4x25)</p>	<p>Protective warning marker, with high-voltage symbol, black, for 5 terminal blocks</p> <p>yellow 2002-115 100 (4x25)</p>	<p>Customized staggered jumper, insulated, I_N 25 A, light gray</p> <p>1-3 2002-473/011-000 100 (4x25) 1-3-5 2002-475/011-000 100 (4x25) 1-3-5-7 2002-477/011-000 100 (4x25) 1-3-5-7-9 2002-479/011-000 100 (4x25) 1-3-5-7-9-11 2002-481/011-000 50 (2x25)</p>
<p>Insulation stop, 5 pcs/strip, 0.25 - 0.5 mm², light gray</p> <p>2002-171 200 (8x25)</p>	<p>Push-in type jumper bar, insulated, I_N 25 A, light gray</p> <p>from 1 to 3 2002-433 200 (8x25) from 1 to 4 2002-434 200 (8x25) from 1 to 5 2002-435 100 (4x25) from 1 to 6 2002-436 100 (4x25) from 1 to 7 2002-437 100 (4x25) from 1 to 8 2002-438 100 (4x25) from 1 to 9 2002-439 100 (4x25) from 1 to 10 2002-440 100 (4x25)</p>	
<p>Insulation stop, 5 pcs/strip, 0.75 - 1 mm², dark gray</p> <p>2002-172 200 (8x25)</p>		
<p>Push-in type jumper bar, insulated, I_N 25 A, light gray</p> <p>2-way 2002-402 200 (8x25) 3-way 2002-403 200 (8x25) 4-way 2002-404 200 (8x25) 5-way 2002-405 100 (4x25) 6-way 2002-406 100 (4x25) 7-way 2002-407 100 (4x25) 8-way 2002-408 100 (4x25) 9-way 2002-409 100 (4x25) 10-way 2002-410 100 (4x25)</p>	<p>Staggered jumper, insulated, I_N 25 A, light gray</p> <p>2-way 2002-472 100 (4x25) 3-way 2002-473 100 (4x25) 4-way 2002-474 100 (4x25) 5-way 2002-475 50 (2x25) 6-way 2002-476 50 (2x25) 7-way 2002-477 50 (2x25) 8-way 2002-478 50 (2x25) 9-way 2002-479 50 (2x25) 10-way 2002-480 50 (2x25) 11-way 2002-481 50 (2x25) 12-way 2002-482 50 (2x25)</p>	<p>Adjacent jumper for continuous commoning, insulated, I_N 25 A, light gray</p> <p>2-way 2002-400 100 (4x25)</p>
<p>Push-in type wire jumper, insulated, I_N 18 A, wire size 1.5 mm²</p> <p>L = 60 mm 2009-412 100 (10x10) L = 110 mm 2009-414 100 (10x10) L = 250 mm 2009-416 100 (10x10)</p>		<p>Modular TOPJOB®S connector, can be snapped together, for jumper contact slot</p> <p>gray 2002-511 100 (4x25)</p> <p>Spacer module, can be snapped together, e.g., for bridging commoned terminal blocks</p> <p>gray 2002-549 100 (4x25)</p> <p>End plate, for modular TOPJOB®S connectors, 1.5 mm thick</p> <p>gray 2002-541 100 (4x25)</p> <p>TOPJOB®S L-test plug module, can be snapped together</p> <p>gray 2002-611 100 (4x25)</p>

TOPJOB® S

Disconnect Terminal Blocks for Test and Measurement, Through Terminal Blocks of Same Profile 2.5 (4) mm², 2002 Series

0.25 - 2.5 (4) mm ² ① 400 V/6 kV/3 ② I _N 16 A Terminal block width 5.2 mm / 0.205 in 10 - 12 mm / 0.43 in ③	AWG 22 - 12 300 V, 15 A ④ 300 V, 10 A ⑤	0.25 - 2.5 (4) mm ² ① 400 V/6 kV/3 ② I _N 16 A Terminal block width 5.2 mm / 0.205 in 10 - 12 mm / 0.43 in ③	AWG 22 - 12 300 V, 15 A ④ 300 V, 10 A ⑤	0.25 - 2.5 (4) mm ² ① 400 V/6 kV/3 ② I _N 16 A Terminal block width 5.2 mm / 0.205 in 10 - 12 mm / 0.43 in ③	AWG 22 - 12 300 V, 15 A ④ 300 V, 10 A ⑤
---	---	---	---	---	---

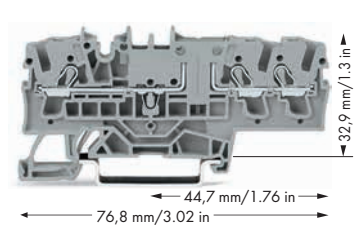
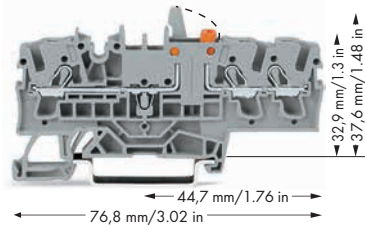
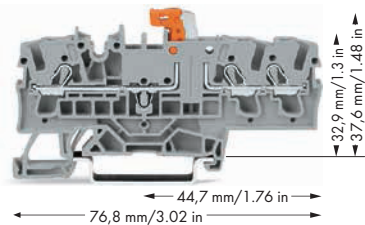

Item No.	Pack. Unit	Item No.	Pack. Unit	Item No.	Pack. Unit
3-conductor disconnect terminal block for test and measurement, with test point, orange disconnect link		3-conductor disconnect terminal block for test and measurement with mechanical interlock, with test point, orange disconnect link		3-conductor through terminal block, with test point, same profile as 3-conductor disconnect terminal block	
gray 2002-1771	50	gray 2002-1771/401-000	50	gray 2002-1701	50
blue 2002-1774	50	blue 2002-1774/401-000	50	blue 2002-1704	50
orange 2002-1772	50	orange 2002-1772/401-000	50	orange 2002-1702	50
Other terminal blocks with the same profile:					
		Carrier 2002-1761		Page 76	
		Fuse 2002-1781		Page 50	

2002 Series Accessories

Appropriate marking systems: WMB/Marking strips/WMB Inline (see Section 13)

End and intermediate plate, 1 mm thick orange 2002-1792 100 (4x25) gray 2002-1791 100 (4x25)	Protective warning marker, with high-voltage symbol, black, for 5 terminal blocks yellow 2002-115 100 (4x25)	Customized staggered jumper, insulated, I_N 25 A, light gray 1-3 2002-473/011-000 100 (4x25) 1-3-5 2002-475/011-000 100 (4x25) 1-3-5-7 2002-477/011-000 100 (4x25) 1-3-5-7-9 2002-479/011-000 100 (4x25) 1-3-5-7-9-11 2002-481/011-000 50 (2x25)
Insulation stop, 5 pcs/strip, 0.25 - 0.5 mm² light gray 2002-171 200 (8x25)	Push-in type jumper bar, insulated, I_N 25 A, light gray from 1 to 3 2002-433 200 (8x25) from 1 to 4 2002-434 200 (8x25) from 1 to 5 2002-435 100 (4x25) from 1 to 6 2002-436 100 (4x25) from 1 to 7 2002-437 100 (4x25) from 1 to 8 2002-438 100 (4x25) from 1 to 9 2002-439 100 (4x25) from 1 to 10 2002-440 100 (4x25)	Adjacent jumper for continuous commoning, insulated, I_N 25 A, light gray 2-way 2002-400 100 (4x25)
Insulation stop, 5 pcs/strip, 0.75 - 1 mm² dark gray 2002-172 200 (8x25)	Staggered jumper, insulated, I_N 25 A, light gray 2-way 2002-472 100 (4x25) 3-way 2002-473 100 (4x25) 4-way 2002-474 100 (4x25) 5-way 2002-475 50 (2x25) 6-way 2002-476 50 (2x25) 7-way 2002-477 50 (2x25) 8-way 2002-478 50 (2x25) 9-way 2002-479 50 (2x25) 10-way 2002-480 50 (2x25) 11-way 2002-481 50 (2x25) 12-way 2002-482 50 (2x25)	Modular TOPJOB®S connector, can be snapped together, for jumper contact slot gray 2002-511 100 (4x25)
Push-in type jumper bar, insulated, I_N 25 A, light gray 2-way 2002-402 200 (8x25) 3-way 2002-403 200 (8x25) 4-way 2002-404 200 (8x25) 5-way 2002-405 100 (4x25) 6-way 2002-406 100 (4x25) 7-way 2002-407 100 (4x25) 8-way 2002-408 100 (4x25) 9-way 2002-409 100 (4x25) 10-way 2002-410 100 (4x25)		Spacer module, can be snapped together, e.g., for bridging commoned terminal blocks gray 2002-549 100 (4x25)
Push-in type wire jumper, insulated, I_N 18 A, wire size 1.5 mm² L = 60 mm 2009-412 100 (10x10) L = 110 mm 2009-414 100 (10x10) L = 250 mm 2009-416 100 (10x10)		End plate, for modular TOPJOB®S connectors, 1.5 mm thick gray 2002-541 100 (4x25)
		TOPJOB®S L-test plug module, can be snapped together gray 2002-611 100 (4x25)

TOPJOB® S

Disconnect Terminal Blocks for Test and Measurement, Through Terminal Blocks of Same Profile 2.5 (4) mm², 2002 Series

0.25 - 2.5 (4) mm ² ① 400 V/6 kV/3 ② I _N 16 A Terminal block width 5.2 mm / 0.205 in 10 - 12 mm / 0.43 in ③	AWG 22 - 12 300 V, 15 A ④ 300 V, 15 A ⑤	0.25 - 2.5 (4) mm ² ① 400 V/6 kV/3 ② I _N 16 A Terminal block width 5.2 mm / 0.205 in 10 - 12 mm / 0.43 in ③	AWG 22 - 12 300 V, 15 A ④ 300 V, 15 A ⑤	0.25 - 2.5 (4) mm ² ① 400 V/6 kV/3 ② I _N 16 A Terminal block width 5.2 mm / 0.205 in 10 - 12 mm / 0.43 in ③	AWG 22 - 12 300 V, 15 A ④ 300 V, 15 A ⑤
---	---	---	---	---	---

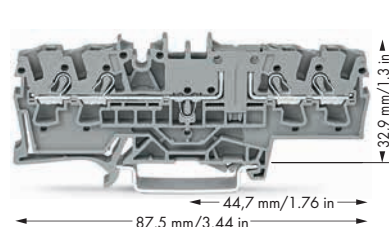
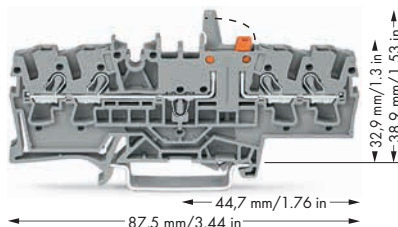
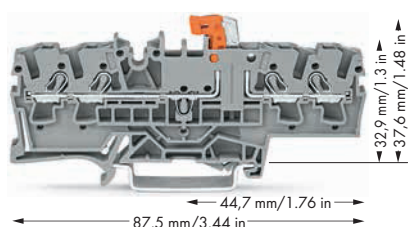

Item No.	Pack. Unit	Item No.	Pack. Unit	Item No.	Pack. Unit
4-conductor disconnect terminal block for test and measurement, with test point, orange disconnect link		4-conductor disconnect terminal block for test and measurement with mechanical interlock, with test point, orange disconnect link		4-conductor through terminal block, with test point, same profile as 4-conductor disconnect terminal block	
gray 2002-1871	50	gray 2002-1871/401-000	50	gray 2002-1801	50
blue 2002-1874	50	blue 2002-1874/401-000	50	blue 2002-1804	50
orange 2002-1872	50	orange 2002-1872/401-000	50	orange 2002-1802	50
Other terminal blocks with the same profile:					
Carrier		2002-1861	Page 76		
Fuse		2002-1881	Page 50		



2002 Series Accessories

Appropriate marking systems: WMB/Marking strips/WMB Inline (see Section 13)

End and intermediate plate, 1 mm thick orange 2002-1892 100 (4x25) gray 2002-1891 100 (4x25)	Protective warning marker, with high-voltage symbol, black, for 5 terminal blocks yellow 2002-115 100 (4x25)	Customized staggered jumper, insulated, I_N 25 A, light gray 1-3 2002-473/011-000 100 (4x25) 1-3-5 2002-475/011-000 100 (4x25) 1-3-5-7 2002-477/011-000 100 (4x25) 1-3-5-7-9 2002-479/011-000 100 (4x25) 1-3-5-7-9-11 2002-481/011-000 50 (2x25)
Insulation stop, 5 pcs/strip, 0.25 - 0.5 mm² light gray 2002-171 200 (8x25)	Push-in type jumper bar, insulated, I_N 25 A, light gray from 1 to 3 2002-433 200 (8x25) from 1 to 4 2002-434 200 (8x25) from 1 to 5 2002-435 100 (4x25) from 1 to 6 2002-436 100 (4x25) from 1 to 7 2002-437 100 (4x25) from 1 to 8 2002-438 100 (4x25) from 1 to 9 2002-439 100 (4x25) from 1 to 10 2002-440 100 (4x25)	Adjacent jumper for continuous commoning, insulated, I_N 25 A, light gray 2-way 2002-400 100 (4x25)
Insulation stop, 5 pcs/strip, 0.75 - 1 mm² dark gray 2002-172 200 (8x25)	Staggered jumper, insulated, I_N 25 A, light gray 2-way 2002-472 100 (4x25) 3-way 2002-473 100 (4x25) 4-way 2002-474 100 (4x25) 5-way 2002-475 50 (2x25) 6-way 2002-476 50 (2x25) 7-way 2002-477 50 (2x25) 8-way 2002-478 50 (2x25) 9-way 2002-479 50 (2x25) 10-way 2002-480 50 (2x25) 11-way 2002-481 50 (2x25) 12-way 2002-482 50 (2x25)	Modular TOPJOB®S connector, can be snapped together, for jumper contact slot gray 2002-511 100 (4x25)
Push-in type jumper bar, insulated, I_N 25 A, light gray 2-way 2002-402 200 (8x25) 3-way 2002-403 200 (8x25) 4-way 2002-404 200 (8x25) 5-way 2002-405 100 (4x25) 6-way 2002-406 100 (4x25) 7-way 2002-407 100 (4x25) 8-way 2002-408 100 (4x25) 9-way 2002-409 100 (4x25) 10-way 2002-410 100 (4x25)	End plate, for modular TOPJOB®S connectors, 1.5 mm thick gray 2002-541 100 (4x25)	TOPJOB®S L-test plug module, can be snapped together gray 2002-611 100 (4x25)
Push-in type wire jumper, insulated, I_N 18 A, wire size 1.5 mm² L = 60 mm 2009-412 100 (10x10) L = 110 mm 2009-414 100 (10x10) L = 250 mm 2009-416 100 (10x10)		

TOPJOB® S

Fuse Disconnect Terminal Blocks with Pivoting Fuse Holder 2.5 (4) mm² for Miniature Fuses 5 x 20 mm, 2002 Series



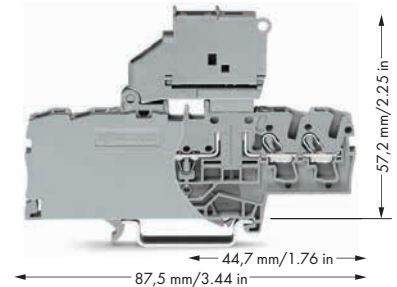
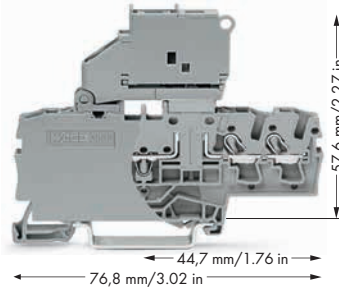
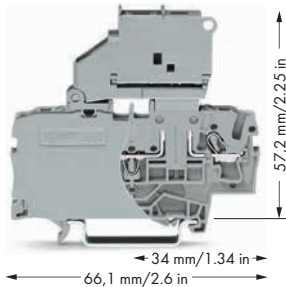



<p>0.25 - 2.5 (4) mm² ① AWG 22 - 12 250 V/6 kV/3 ② I_N 6.3 A</p> <p>Terminal block width 6.2 mm / 0.244 in  10 - 12 mm / 0.43 in ③</p>	<p>0.25 - 2.5 (4) mm² ① AWG 22 - 12 250 V/6 kV/3 ② I_N 6.3 A</p> <p>Terminal block width 6.2 mm / 0.244 in  10 - 12 mm / 0.43 in ③</p>	<p>0.25 - 2.5 (4) mm² ① AWG 22 - 12 250 V/6 kV/3 ② I_N 6.3 A</p> <p>Terminal block width 6.2 mm / 0.244 in  10 - 12 mm / 0.43 in ③</p>
--	---	---



Item No.	Pack. Unit	Item No.	Pack. Unit	Item No.	Pack. Unit
2-conductor fuse disconnect terminal block with pivoting fuse holder, for miniature fuses 5 x 20 mm, without blown fuse indication Both nominal voltage and current are given by the fuse.		3-conductor fuse disconnect terminal block with pivoting fuse holder, for miniature fuses 5 x 20 mm, without blown fuse indication Both nominal voltage and current are given by the fuse.		4-conductor fuse disconnect terminal block with pivoting fuse holder, for miniature fuses 5 x 20 mm, without blown fuse indication Both nominal voltage and current are given by the fuse.	
● gray	2002-1611 50	● gray	2002-1711 50	● gray	2002-1811 50
2-conductor fuse disconnect terminal block with pivoting fuse holder, for miniature fuses 5 x 20 mm, with blown fuse indication by LED, gray Both nominal voltage and current are given by the LED or fuse. Leakage current in case of blown fuse: LED 2mA		3-conductor fuse disconnect terminal block with pivoting fuse holder, for miniature fuses 5 x 20 mm, with blown fuse indication by LED, gray Both nominal voltage and current are given by the LED or fuse. Leakage current in case of blown fuse: LED 2mA		4-conductor fuse disconnect terminal block with pivoting fuse holder, for miniature fuses 5 x 20 mm, with blown fuse indication by LED, gray Both nominal voltage and current are given by the LED or fuse. Leakage current in case of blown fuse: LED 2mA	
● 12 - 30 V	2002-1611/1000-541 50	● 12 - 30 V	2002-1711/1000-541 50	● 12 - 30 V	2002-1811/1000-541 50
● 30 - 65 V	2002-1611/1000-542 50	● 30 - 65 V	2002-1711/1000-542 50	● 30 - 65 V	2002-1811/1000-542 50
● 230 V	2002-1611/1000-836 50	● 230 V	2002-1711/1000-836 50	● 230 V	2002-1811/1000-836 50
● 120 V	2002-1611/1000-867 50	● 120 V	2002-1711/1000-867 50	● 120 V	2002-1811/1000-867 50

Accessories

Appropriate marking systems: WMB/WMB Inline/Marking strips
(see Section 13)

<p>End plate for fuse terminal blocks,  2 mm thick orange 2002-992 100 (4x25) gray 2002-991 100 (4x25)</p>	<p>Push-in type jumper bar, insulated,  I_N 32 A, light gray 2-way 2004-402 200 (8x25) 3-way 2004-403 200 (8x25) 4-way 2004-404 100 (4x25) 5-way 2004-405 100 (4x25) 6-way 2004-406 100 (4x25) 7-way 2004-407 100 (4x25) 8-way 2004-408 100 (4x25) 9-way 2004-409 100 (4x25) 10-way 2004-410 100 (4x25)</p>	<p>Push-in type jumper bar, insulated,  I_N 32 A, light gray from 1 to 3 2004-433 200 (8x25) from 1 to 4 2004-434 200 (8x25) from 1 to 5 2004-435 100 (4x25) from 1 to 6 2004-436 100 (4x25) from 1 to 7 2004-437 100 (4x25) from 1 to 8 2004-438 100 (4x25) from 1 to 9 2004-439 100 (4x25) from 1 to 10 2004-440 100 (4x25)</p>
<p>Insulation stop,  5 pcs/strip, 0.25 - 0.5 mm² light gray 2002-171 200 (8x25)</p>		
<p>Insulation stop,  5 pcs/strip, 0.75 - 1 mm² dark gray 2002-172 200 (8x25)</p>		
<p>Push-in type wire jumper,  ④ insulated, I_N 18 A, wire size 1.5 mm² L = 60 mm 2009-412 100 (10x10) L = 110 mm 2009-414 100 (10x10) L = 250 mm 2009-416 100 (10x10)</p>	<p>Protective warning marker,  with high-voltage symbol, black, for 5 terminal blocks yellow 2002-115 100 (4x25)</p>	



Fuse terminal blocks with a width of 6.2 mm can be assembled adjacently. If there is **no** adjacent fuse terminal block at the end of the assembly, an end plate must be used.

- ❶ Conductor sizes: 0.25 mm² – 4 mm² "s + f-st";
Push-in conductor sizes: 0.75 mm² – 4 mm² "s"
and 0.75 mm² – 2.5 mm² "insulated ferrule, 12 mm"
- ❷ 250 V = rated voltage
6 kV = rated surge voltage
3 = pollution degree
(see Section 14)
- ❸ Strip length, see packaging or instructions.
- ❹ See application notes for:
Push-in type wire jumper, page 102

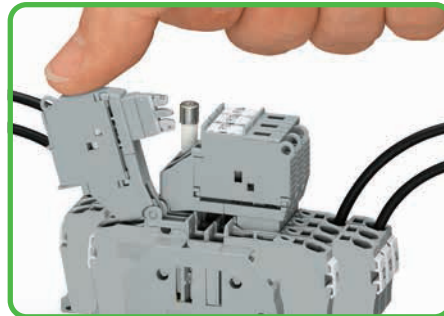

Pivoting the fuse holder in the locked open position.

When selecting miniature fuses, the maximum power loss listed below should not be exceeded. The power loss is determined according to IEC or EN 60947-7-3/VDE 0611-6 at 23 °C. The temperature rise of the terminal blocks must be checked according to their application and mounting. Higher ambient temperatures place additional strain on fuse cartridges. Therefore, in such applications, the rated current must be reduced if necessary. More details available from the manufacturer.



Exchanging fuse.



Miniature fuses 5 x 20

Series Item No.	Overload and short circuit protection		Short circuit protection only	
	Individual argmt.	Group argmt.	Individual argmt.	Group argmt.
Fuse terminal blocks				
2002-1611	1.6 W	1.6 W	2.5 W	2.5 W
2002-1811				
2002-1611/.....	1.6 W	1.6 W	2.5 W	2.5 W
2002-1811/.....				

Protective warning marker and insulation stop must be applied individually. Due to the 6.2 mm width of the fuse terminal blocks with pivoting fuse holder, 2004 Series jumpers must be used.

TOPJOB® S

Disconnect Terminal Blocks for Test and Measurement without and with Mechanical Interlock with Additional Jumper Position 2.5 (4) mm², 2002 Series

<p>0.25 - 2.5 (4) mm² ① AWG 22 - 12 400 V/6 kV/3 ② I_N 16 A</p> <p>Terminal block width 5.2 mm / 0.205 in  10 - 12 mm / 0.43 in ③</p>	<p>0.25 - 2.5 (4) mm² ① AWG 22 - 12 400 V/6 kV/3 ② I_N 16 A</p> <p>Terminal block width 5.2 mm / 0.205 in  10 - 12 mm / 0.43 in ③</p>	<p>0.25 - 2.5 (4) mm² ① AWG 22 - 12 400 V/6 kV/3 ② I_N 16 A</p> <p>Terminal block width 5.2 mm / 0.205 in  10 - 12 mm / 0.43 in ③</p>
---	--	--

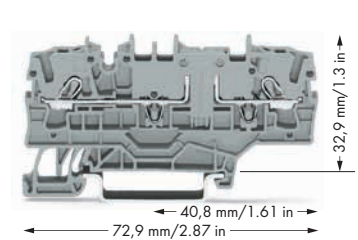
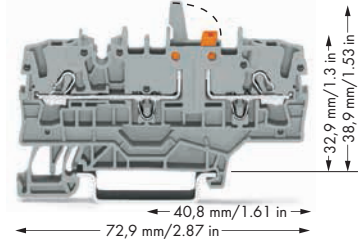
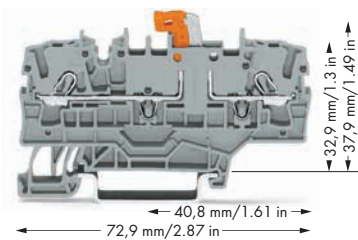

Item No.	Pack. Unit	Item No.	Pack. Unit	Item No.	Pack. Unit
2-conductor disconnect terminal block for test and measurement, with test point, orange disconnect link, with additional jumper position		2-conductor disconnect terminal block for test and measurement with mechanical interlock, with test point, orange disconnect link, with additional jumper position		2-conductor through terminal block, with test point, with additional jumper position, same profile as 2-conductor disconnect terminal block	
gray 2002-1971 50		gray 2002-1971/401-000 50		gray 2002-1901 50	
blue 2002-1974 50		orange 2002-1972/401-000 50		blue 2002-1904 50	
orange 2002-1972 50		blue 2002-1974/401-000 50		orange 2002-1902 50	
				2-conductor ground terminal block	
				green-yellow 2002-1907 50	
				Other terminal blocks with the same profile:	
				Carrier 2002-1961 Page 76	
				Fuse 2002-1981 Page 57	

2002 Series Accessories



Appropriate marking systems: WMB/Marking strips/WMB Inline
(see Section 13)

<p>End and intermediate plate, 1 mm thick</p> <p>orange 2002-1992 100 (4x25)</p> <p>gray 2002-1991 100 (4x25)</p>	<p>Push-in type jumper bar, insulated,</p> <p>I_N 25 A, light gray</p> <p>from 1 to 3 2002-433 200 (8x25)</p> <p>from 1 to 4 2002-434 200 (8x25)</p> <p>from 1 to 5 2002-435 100 (4x25)</p> <p>from 1 to 6 2002-436 100 (4x25)</p> <p>from 1 to 7 2002-437 100 (4x25)</p> <p>from 1 to 8 2002-438 100 (4x25)</p> <p>from 1 to 9 2002-439 100 (4x25)</p> <p>from 1 to 10 2002-440 100 (4x25)</p>	<p>Protective warning marker,</p> <p>with high-voltage symbol, black, for 5 terminal blocks</p> <p>yellow 2002-115 100 (4x25)</p>
<p>Insulation stop,</p> <p>5 pcs/strip, 0.25 - 0.5 mm²</p> <p>light gray 2002-171 200 (8x25)</p>		<p>Test plug adapter,</p> <p>for 4 mm Ø test plug</p> <p>gray 2009-174 100 (4x25)</p>
<p>Insulation stop,</p> <p>5 pcs/strip, 0.75 - 1 mm²</p> <p>dark gray 2002-172 200 (8x25)</p>		<p>Testing tap,</p> <p>for max. 2.5 mm²</p> <p>gray 2009-182 100 (4x25)</p>
<p>Push-in type jumper bar, insulated,</p> <p>I_N 25 A, light gray</p> <p>2-way 2002-402 200 (8x25)</p> <p>3-way 2002-403 200 (8x25)</p> <p>4-way 2002-404 200 (8x25)</p> <p>5-way 2002-405 100 (4x25)</p> <p>6-way 2002-406 100 (4x25)</p> <p>7-way 2002-407 100 (4x25)</p> <p>8-way 2002-408 100 (4x25)</p> <p>9-way 2002-409 100 (4x25)</p> <p>10-way 2002-410 100 (4x25)</p>	<p>Staggered jumper,</p> <p>insulated, I_N 25 A, light gray</p> <p>2-way 2002-472 100 (4x25)</p> <p>3-way 2002-473 100 (4x25)</p> <p>4-way 2002-474 100 (4x25)</p> <p>5-way 2002-475 50 (2x25)</p> <p>6-way 2002-476 50 (2x25)</p> <p>7-way 2002-477 50 (2x25)</p> <p>8-way 2002-478 50 (2x25)</p> <p>9-way 2002-479 50 (2x25)</p> <p>10-way 2002-480 50 (2x25)</p> <p>11-way 2002-481 50 (2x25)</p> <p>12-way 2002-482 50 (2x25)</p>	<p>Modular TOPJOB®S connector,</p> <p>can be snapped together, for jumper contact slot</p> <p>gray 2002-511 100 (4x25)</p>
<p>Push-in type wire jumper,</p> <p>insulated, I_N 18 A, wire size 1.5 mm²</p> <p>L = 60 mm 2009-412 100 (10x10)</p> <p>L = 110 mm 2009-414 100 (10x10)</p> <p>L = 250 mm 2009-416 100 (10x10)</p>	<p>Adjacent jumper for continuous commoning, insulated,</p> <p>I_N 25 A, light gray</p> <p>2-way 2002-400 100 (4x25)</p>	<p>Spacer module, can be snapped together, e.g., for bridging commoned terminal blocks</p> <p>gray 2002-549 100 (4x25)</p>
		<p>End plate,</p> <p>for modular TOPJOB®S connectors, 1.5 mm thick</p> <p>gray 2002-541 100 (4x25)</p>
		<p>TOPJOB®S L-test plug module,</p> <p>can be snapped together</p> <p>gray 2002-611 100 (4x25)</p>
		<p>Test plug,</p> <p>with 500 mm cable, 2 mm Ø</p> <p>red 210-136 50</p>

TOPJOB® S

Fuse Terminal Blocks 2.5 (4) mm²

2002 Series

<p>0.25 - 2.5 (4) mm² ① AWG 22 - 12 400 V/6 kV/3 ② I_N 10 A</p> <p>Terminal block width 5.2 mm / 0.205 in  10 - 12 mm / 0.43 in ③</p>	<p>0.25 - 2.5 (4) mm² ① AWG 22 - 12 400 V/6 kV/3 ② I_N 10 A</p> <p>Terminal block width 5.2 mm / 0.205 in  10 - 12 mm / 0.43 in ③</p>	<p>0.25 - 2.5 (4) mm² ① AWG 22 - 12 400 V/6 kV/3 ② I_N 10 A</p> <p>Terminal block width 5.2 mm / 0.205 in  10 - 12 mm / 0.43 in ③</p>
---	--	--

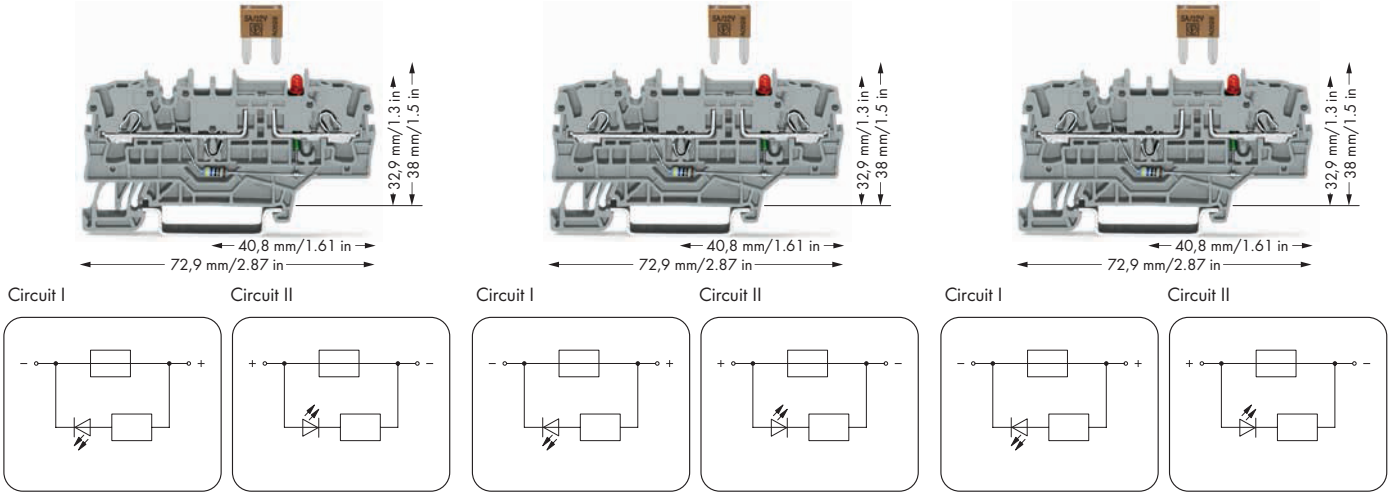

Item No.	Pack. Unit	Item No.	Pack. Unit	Item No.	Pack. Unit
2-conductor fuse terminal block for mini-automotive blade-style fuses, 12V, with test point, with blown fuse indication by LED, LED power consumption: 4.8 mA, gray Both nominal voltage and current are given by the LED or fuse. Blade-style fuses, please note touchproof protection for 42V and higher.		2-conductor fuse terminal block for mini-automotive blade-style fuses, 24 V, with test point, with blown fuse indication by LED, LED power consumption: 4.8 mA, gray Both nominal voltage and current are given by the LED or fuse. Blade-style fuses, please note touchproof protection for 42V and higher.		2-conductor fuse terminal block for mini-automotive blade-style fuses, 48 V, with test point, with blown fuse indication by LED, LED power consumption: 4.8 mA, gray Both nominal voltage and current are given by the LED or fuse. Blade-style fuses, please note touchproof protection for 42V and higher.	
○ Circuit I	2002-1981/1000-429 50	○ Circuit I	2002-1981/1000-413 50	○ Circuit I	2002-1981/1000-414 50
○ Circuit II	2002-1981/1000-449 50	○ Circuit II	2002-1981/1000-434 50	○ Circuit II	2002-1981/1000-435 50
Other terminal blocks with the same profile:					
Through	2002-1901	Page 54			

2002 Series Accessories



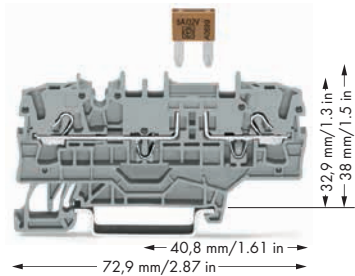

Appropriate marking systems: WMB/Marking strips/WMB Inline
(see Section 13)

<p>End and intermediate plate, 1 mm thick</p> <p>orange 2002-1992 100 (4x25) gray 2002-1991 100 (4x25)</p>	<p>Push-in type wire jumper,</p> <p>④ insulated, I_N 18 A, wire size 1.5 mm²</p> <p>L = 60 mm 2009-412 100 (10x10) L = 110 mm 2009-414 100 (10x10) L = 250 mm 2009-416 100 (10x10)</p>	<p>Staggered jumper,</p> <p>④ insulated, I_N 25 A, light gray</p> <p>2-way 2002-472 100 (4x25) 3-way 2002-473 100 (4x25) 4-way 2002-474 100 (4x25) 5-way 2002-475 50 (2x25) 6-way 2002-476 50 (2x25) 7-way 2002-477 50 (2x25) 8-way 2002-478 50 (2x25) 9-way 2002-479 50 (2x25) 10-way 2002-480 50 (2x25) 11-way 2002-481 50 (2x25) 12-way 2002-482 50 (2x25)</p>
<p>Insulation stop,</p> <p>5 pcs/strip, 0.25 - 0.5 mm² light gray 2002-171 200 (8x25)</p>	<p>Adjacent jumper for continuous commoning, insulated,</p> <p>④ I_N 25 A, light gray</p> <p>2-way 2002-400 100 (4x25)</p>	
<p>Insulation stop,</p> <p>5 pcs/strip, 0.75 - 1 mm² dark gray 2002-172 200 (8x25)</p>	<p>Push-in type jumper bar, insulated,</p> <p>④ I_N 25 A, light gray</p> <p>2-way 2002-402 200 (8x25) 3-way 2002-403 200 (8x25) 4-way 2002-404 200 (8x25) 5-way 2002-405 100 (4x25) 6-way 2002-406 100 (4x25) 7-way 2002-407 100 (4x25) 8-way 2002-408 100 (4x25) 9-way 2002-409 100 (4x25) 10-way 2002-410 100 (4x25)</p>	
	<p>Push-in type jumper bar, insulated,</p> <p>I_N 25 A, light gray</p> <p>from 1 to 3 2002-433 200 (8x25) from 1 to 4 2002-434 200 (8x25) from 1 to 5 2002-435 100 (4x25) from 1 to 6 2002-436 100 (4x25) from 1 to 7 2002-437 100 (4x25) from 1 to 8 2002-438 100 (4x25) from 1 to 9 2002-439 100 (4x25) from 1 to 10 2002-440 100 (4x25)</p>	
		<p>Protective warning marker,</p> <p>with high-voltage symbol, black, for 5 terminal blocks yellow 2002-115 100 (4x25)</p>



0.25 - 2.5 (4) mm² ① AWG 22 - 12
 400 V/6 kV/3 ②
 I_N 10 A
 Terminal block width 5.2 mm / 0.205 in
 10 - 12 mm / 0.43 in ③



- ① Conductor sizes: 0.25 mm² - 4 mm² "s + f-st";
 Push-in conductor sizes: 0.75 mm² - 4 mm² "s"
 and 0.75 mm² - 2.5 mm²
 "insulated ferrules, 12 mm"
- ② 400 V = rated voltage
 6 kV = rated surge voltage
 3 = pollution degree
 (see Section 14)
- ③ Strip length, see packaging or instructions.
- ④ See application notes for:
 Colored push-in type jumper bars, page 101
 Staggered jumper, page 104
 Adjacent jumper for continuous commoning,
 page 101
 Push-in type wire jumper, page 102
 TOPJOB®S connector, page 96
 TOPJOB®S L-type test plug module, page 100

Item No.	Pack. Unit
2-conductor fuse terminal block for mini-automotive blade-style fuses,	
with test point, with additional jumper position, without blown fuse indication	
Both nominal voltage and current are given by the fuse.	
Blade-style fuses, please note touchproof protection for 42V and higher.	
 gray	2002-1981 50
Blade-style fuses are not offered by WAGO	
WMB Inline, plain,	
stretchable 5 - 5.2 mm,  1,500 WMB markers, 5 mm, on roll white 2009-115 1	
WMB Multi marking system,	
10 strips with 10 markers per card,  stretchable 5 - 5.2 mm plain 793-5501 5	
Double-deck marker carrier,	
pivoting  gray 2002-121 50 (2x25)	

Fuse Disconnect Terminal Blocks with Pivoting Fuse Holder and Additional Jumper Position for Miniature Fuses 5 x 20 mm, 2002 Series

<p>0.25 - 2.5 (4) mm² ① AWG 22 - 12 250 V/6 kV/3 ② I_N 6.3 A</p> <p>Terminal block width 6.2 mm / 0.244 in  10 - 12 mm / 0.43 in ③</p>	<p>0.25 - 2.5 (4) mm² ① AWG 22 - 12 250 V/6 kV/3 ② I_N 6.3 A</p> <p>Terminal block width 6.2 mm / 0.244 in  10 - 12 mm / 0.43 in ③</p>
--	---

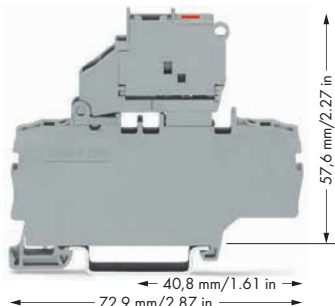
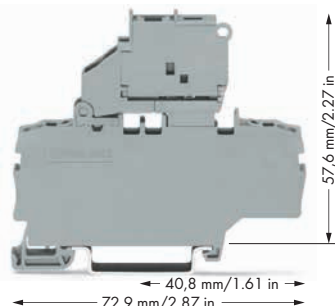

- ① Conductor sizes: 0.25 mm² - 4 mm² "s + f-st";
 Push-in conductor sizes: 0.75 mm² - 4 mm² "s"
 and 0.75 mm² - 2.5 mm²
 "insulated ferrule, 12 mm"
- ② 250 V = rated voltage
 6 kV = rated surge voltage
 3 = pollution degree
 (see Section 14)
- ③ Strip length, see packaging or instructions.
- ④ See application notes for:
 Push-in type wire jumper, page 102





Item No.	Pack. Unit	Item No.	Pack. Unit
2-conductor fuse disconnect terminal block with pivoting fuse holder, with additional jumper position, for miniature fuses 5 x 20 mm, without blown fuse indication Both nominal voltage and current are given by the fuse.		2-conductor fuse disconnect terminal block with pivoting fuse holder, with additional jumper position, for miniature fuses 5 x 20 mm, with blown fuse indication by LED, gray Both nominal voltage and current are given by the LED or fuse. Leakage current in case of blown fuse: LED 2mA	
● gray	2002-1911	50	
●	12 - 30 V	2002-1911/1000-541	50
●	30 - 65 V	2002-1911/1000-542	50
●	120 V	2002-1911/1000-867	50
●	230 V	2002-1911/1000-836	50

Series Item No.	Overload and short circuit protection		Short circuit protection only	
	Individual argmt.	Group argmt.	Individual argmt.	Group argmt.
Fuse terminal blocks				
2002-1911	1.6 W	1.6 W	2.5 W	2.5 W
2002-1911/.....	1.6 W	1.6 W	2.5 W	2.5 W

Protective warning marker and insulation stop must be applied individually. Due to the 6.2 mm width of the fuse terminal blocks with pivoting fuse holder, 2004 Series jumpers must be used.

2002 Series Accessories



Appropriate marking systems: WMB/Marking strips/WMB Inline (see Section 13)

End plate for fuse terminal blocks, 2 mm thick  orange 2002-992 100 (4x25) gray 2002-991 100 (4x25)	Push-in type jumper bar, insulated, I _N 32 A, light gray  from 1 to 3 2004-433 200 (8x25) from 1 to 4 2004-434 200 (8x25) from 1 to 5 2004-435 100 (4x25) from 1 to 6 2004-436 100 (4x25) from 1 to 7 2004-437 100 (4x25) from 1 to 8 2004-438 100 (4x25) from 1 to 9 2004-439 100 (4x25) from 1 to 10 2004-440 100 (4x25)
Insulation stop, 5 pcs/strip, 0.25 - 0.5 mm ² light gray 2002-171 200 (8x25)	Push-in type wire jumper, ④ insulated, I _N 18 A, wire size 1.5 mm ²  L = 60 mm 2009-412 100 (10x10) L = 110 mm 2009-414 100 (10x10) L = 250 mm 2009-416 100 (10x10)
Insulation stop, 5 pcs/strip, 0.75 - 1 mm ² dark gray 2002-172 200 (8x25)	Protective warning marker, with high-voltage symbol, black, for 5 terminal blocks  yellow 2002-115 100 (4x25)
Push-in type jumper bar, insulated, I _N 32 A, light gray 2-way 2004-402 200 (8x25) 3-way 2004-403 200 (8x25) 4-way 2004-404 100 (4x25) 5-way 2004-405 100 (4x25) 6-way 2004-406 100 (4x25) 7-way 2004-407 100 (4x25) 8-way 2004-408 100 (4x25) 9-way 2004-409 100 (4x25) 10-way 2004-410 100 (4x25)	Test plug, with 500 mm cable, 2 mm Ø red 210-136 50









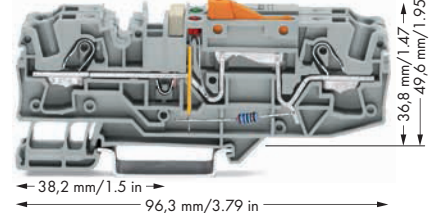
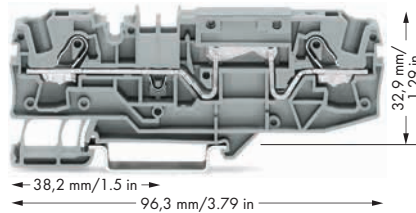
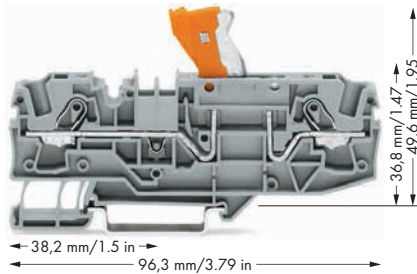





When selecting miniature fuses, the maximum power loss listed below should not be exceeded. The power loss is determined according to IEC or EN 60947-7-3/VDE 0611-6 at 23°C. The temperature rise of the terminal blocks must be checked according to their application and mounting. Higher ambient temperatures are an additional burden on fuse cartridges. Therefore, in such applications the rated current must be reduced if necessary. More details available from the manufacturer.

TOPJOB® S

Disconnect and Ground Conductor Disconnect Terminal Blocks 6 (10) mm² / 30 A and Through Terminal Blocks of Same Profile, 2006 Series







<p>0.5 - 6 (10) mm² ① AWG 20 - 8 800 V/8 kV/3 ② I_N 30 A</p> <p>Terminal block width 7.5 mm / 0.295 in  13 - 15 mm / 0.55 in ③</p>	<p>0.5 - 6 (10) mm² ① AWG 20 - 8 800 V/8 kV/3 ② I_N 30 A</p> <p>Terminal block width 7.5 mm / 0.295 in  13 - 15 mm / 0.55 in ③</p>	<p>0.5 - 6 (10) mm² ① AWG 20 - 8</p> <p>Terminal block width 15 mm / 0.591 in  13 - 15 mm / 0.55 in ③</p>
--	---	--



Item No.	Pack. Unit	Item No.	Pack. Unit	Item No.	Pack. Unit
2-conductor disconnect terminal block, with test point, orange disconnect link		2-conductor through terminal block, with test point, same profile as 2-conductor disconnect terminal block		Ground conductor disconnect terminal block, with test point, orange disconnect link, gray	
<ul style="list-style-type: none">  gray 2006-1671 25  blue 2006-1674 25 		<ul style="list-style-type: none">  gray 2006-1601 25  blue 2006-1604 25 		<ul style="list-style-type: none">  24 V 2006-1671/1000-848 12  48 V 2006-1671/1000-849 12  120 V 2006-1671/1000-850 12  230 V 2006-1671/1000-851 12 	
Other terminal blocks with the same profile: Through 2006-1601 Page 60		Other terminal blocks with the same profile: Carrier 2006-1661 Page 78 Fuse 2006-1681 Page 62		Other terminal blocks with the same profile: Through 2006-1601 Page 60	
Item-Specific Accessories		Item-Specific Accessories		Item-Specific Accessories	
Push-in type jumper bar, insulated,  I _N 41 A, light gray 2-way 2006-402 50 (2x25) 3-way 2006-403 50 (2x25) 4-way 2006-404 50 (2x25) 5-way 2006-405 50 (2x25)		Push-in type jumper bar, insulated,  I _N 41 A, light gray 2-way 2006-402 50 (2x25) 3-way 2006-403 50 (2x25) 4-way 2006-404 50 (2x25) 5-way 2006-405 50 (2x25)		Push-in type jumper bar, insulated,  I _N 41 A, light gray 2-way 2006-402 50 (2x25)	
Push-in type jumper bar, insulated,  I _N 41 A, light gray from 1 to 3 2006-433 50 (2x25) from 1 to 4 2006-434 50 (2x25) from 1 to 5 2006-435 50 (2x25)		Push-in type jumper bar, insulated,  I _N 41 A, light gray from 1 to 3 2006-433 50 (2x25) from 1 to 4 2006-434 50 (2x25) from 1 to 5 2006-435 50 (2x25)			
Star point jumper, insulated,  I _N = I _N terminal block, light gray 1-3-5 2006-405/011-000 50 (2x25)		Star point jumper, insulated,  I _N = I _N terminal block, light gray 1-3-5 2006-405/011-000 50 (2x25)			

2006 Series Accessories

Appropriate marking systems: WMB/Marking strips
(see Section 13)

End and intermediate plate, 1 mm thick  orange 2006-1692 100 (4x25) gray 2006-1691 100 (4x25)	Double-deck marker carrier, pivoting  gray 2002-121 50 (2x25)	Screwless end stop,  for DIN 35 rail, 6 mm wide gray 249-116 100 (4x25)
Protective warning marker,  with high-voltage symbol, black, for 5 terminal blocks yellow 2006-115 100 (4x25)	WMB Multi marking system,  10 strips with 10 markers per card, stretchable 5 - 5.2 mm plain 793-5501 5	Screwless end stop,  for DIN 35 rail, 10 mm wide gray 249-117 50 (2x25)
	Marking strip, plain,  11 mm wide, 50 m roll white 2009-110 1	

Disconnect and Ground Conductor Disconnect Terminal Blocks



Ground conductor disconnect terminal block – top view

- 1 Conductor sizes: 0.5 mm² – 10 mm² "s + f-st";
Push-in conductor sizes: 1 mm² – 10 mm² "s"
and 1.5 mm² – 6 mm²
"insulated ferrule, 12 mm"
- 2 800 V = rated voltage
8 kV = rated surge voltage
3 = pollution degree
(see Section 14)
- 3 Strip length, see packaging or instructions.

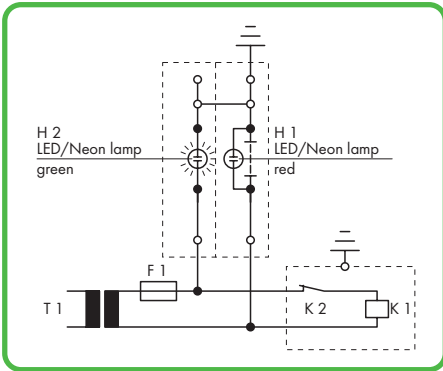

Operating condition
Slide link closed, auxiliary circuit grounded, green lamp illuminates.

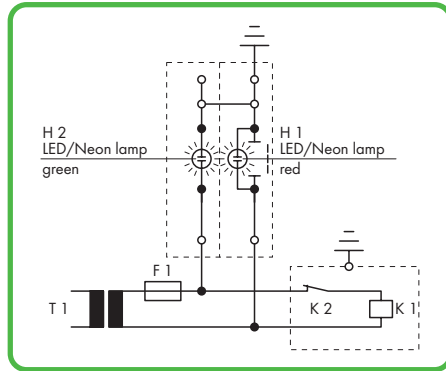

Test condition – no grounding
Slide link open, auxiliary circuit not grounded.

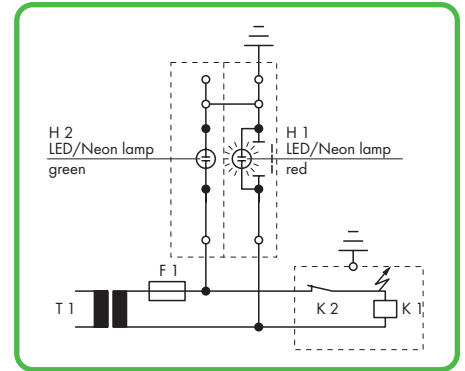

Test condition – grounding
Slide link open, auxiliary circuit not grounded, red lamp illuminates.

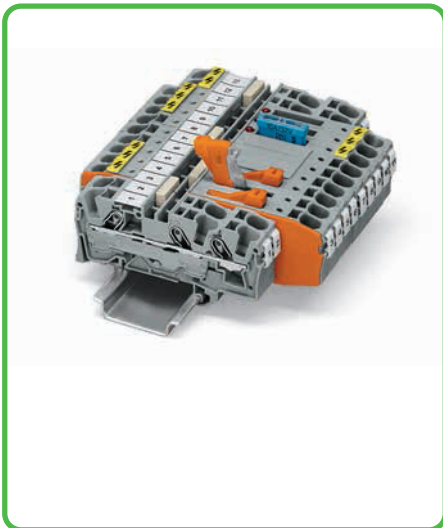

Terminal block assembly including:
Through terminal blocks
N-conductor disconnect terminal blocks
Fuse terminal blocks for mini-automotive fuses

IEC 60204/DIN VDE 0113 "Electrical equipment of industrial machines, part 1: General requirements" 9.4.3.1:

Ground faults on control circuits shall not cause unintentional starting, hazardous movements or prevent stopping the machine.

In order to fulfill this requirement, bonding to the protective bonding circuit shall be provided in accordance with 8.2 and the devices shall be connected as described in 9.1.4. Control circuits fed from a transformer and not connected to the protective bonding circuit shall be provided with an insulation monitoring device (e.g., residual current device), which either indicates a ground fault or interrupts the circuit automatically after a ground fault.

In the case of electronic circuits, the connection of one side of the control circuit to the protective bonding circuit in accordance with 9.1.4 can prevent unintentional operation. When this does not help, or if due to other reasons electronic circuits cannot be connected to the protective bonding circuit, other measures shall be taken to achieve the same level of safety.

Multipole control switches which interrupt all live conductors shall be used where the control circuit is directly connected between the phase conductors of the supply or between a phase conductor and a neutral conductor, which is either not grounded or grounded through a high impedance. This is required for starting or stopping those machine functions, which can cause a hazardous situation including: damaging the machine or halting the work in progress, in the event of unintentional starting or failure to stop.

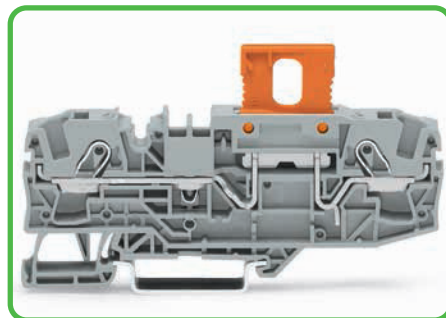

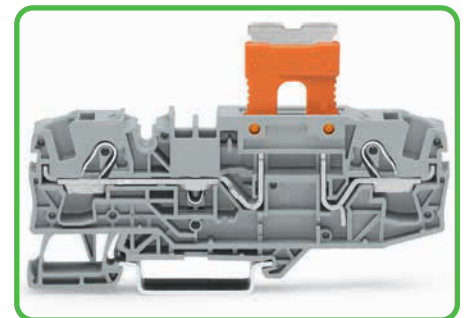

Carrier terminal block with disconnect plug in operating position.



Carrier terminal block with disconnect plug in parked position.

TOPJOB® S Fuse Terminal Blocks for Mini-Automotive Blade-Style Fuses 6 (10) mm² 2006 Series

<p>0.5 - 6 (10) mm² ① AWG 20 - 8 500 V/8 kV/3 ② I_N 25 A (30 A) ③</p> <p>Terminal block width 7.5 mm / 0.295 in  13 - 15 mm / 0.55 in ④</p>	<p>0.5 - 6 (10) mm² ① AWG 20 - 8 500 V/8 kV/3 ② I_N 25 A (30 A) ③</p> <p>Terminal block width 7.5 mm / 0.295 in  13 - 15 mm / 0.55 in ④</p>	<p>0.5 - 6 (10) mm² ① AWG 20 - 8 500 V/8 kV/3 ② I_N 25 A (30 A) ③</p> <p>Terminal block width 7.5 mm / 0.295 in  13 - 15 mm / 0.55 in ④</p>
---	--	--

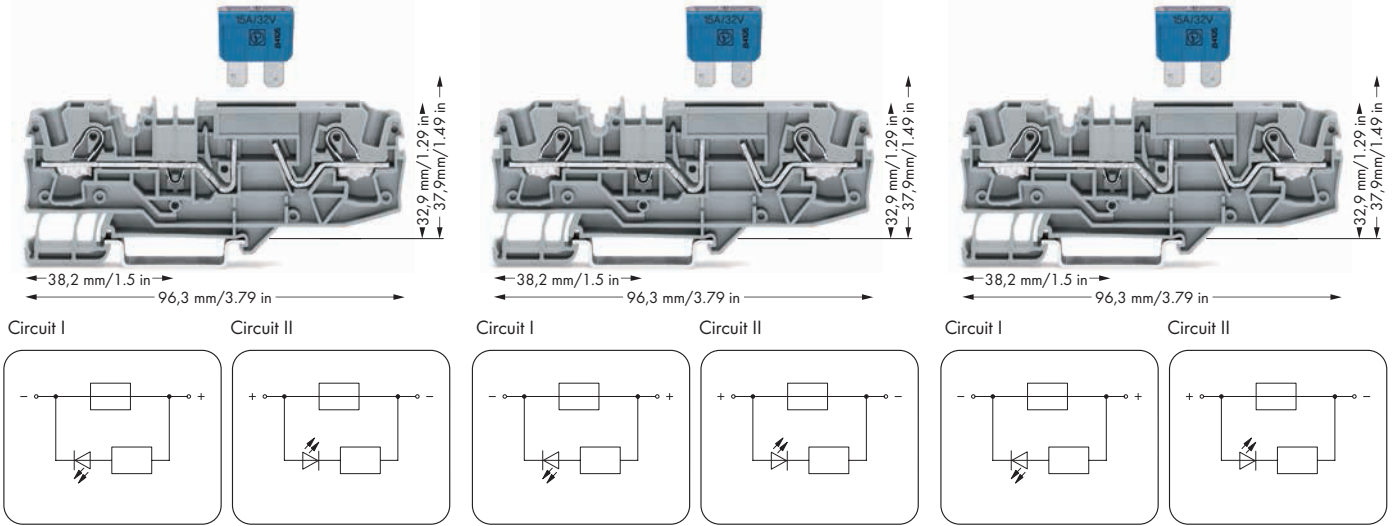

Item No.	Pack. Unit	Item No.	Pack. Unit	Item No.	Pack. Unit
2-conductor fuse terminal block for mini-automotive blade-style fuses, 12V, with test point, with blown fuse indication by LED, LED power consumption: 4.8 mA, gray Both nominal voltage and current are given by the LED or fuse. Blade-style fuses, please note touchproof protection for 42V and higher.		2-conductor fuse terminal block for mini-automotive blade-style fuses, 24V, with test point, with blown fuse indication by LED, LED power consumption: 4.8 mA, gray Both nominal voltage and current are given by the LED or fuse. Blade-style fuses, please note touchproof protection for 42V and higher.		2-conductor fuse terminal block for mini-automotive blade-style fuses, 48V, with test point, with blown fuse indication by LED, LED power consumption: 4.8 mA, gray Both nominal voltage and current are given by the LED or fuse. Blade-style fuses, please note touchproof protection for 42V and higher.	
○ Circuit I	2006-1681/1000-429 25	○ Circuit I	2006-1681/1000-413 25	○ Circuit I	2006-1681/1000-414 25
○ Circuit II	2006-1681/1000-449 25	○ Circuit II	2006-1681/1000-434 25	○ Circuit II	2006-1681/1000-435 25
Other terminal blocks with the same profile:					
Through	2006-1601	Page 60			

2006 Series Accessories

Appropriate marking systems: WMB/Marking strips (see Section 13)

<p>End and intermediate plate, 1 mm thick</p> <p>orange 2006-1692 100 (4x25)</p> <p>gray 2006-1691 100 (4x25)</p>	<p>Protective warning marker, with high-voltage symbol, black, for 5 terminal blocks yellow 2006-115 100 (4x25)</p>
<p>Push-in type jumper bar, insulated, I_N 41 A, light gray</p> <p>2-way 2006-402 50 (2x25)</p> <p>3-way 2006-403 50 (2x25)</p> <p>4-way 2006-404 50 (2x25)</p> <p>5-way 2006-405 50 (2x25)</p>	<p>WMB Multi marking system, 10 strips with 10 markers per card, stretchable 5 - 5.2 mm plain 793-5501 5</p> <p>Marking strip, plain, 11 mm wide, 50 m roll white 2009-110 1</p>
<p>Push-in type jumper bar, insulated, I_N 41 A, light gray</p> <p>from 1 to 3 2006-433 50 (2x25)</p> <p>from 1 to 4 2006-434 50 (2x25)</p> <p>from 1 to 5 2006-435 50 (2x25)</p>	<p>Double-deck marker carrier, pivoting gray 2002-121 50 (2x25)</p>

Fuse Disconnect Terminal Blocks with Pivoting Fuse Holder for Miniature Fuses 5 x 20 mm, 5 x 30 mm, 1/4" x 1 1/4", 2006 Series

0.5 - 6 (10) mm ² ① AWG 20 - 8 800 V/8 kV/3 ② 600 V, 15 A ③ I _N 10 A Terminal block width 7.5 mm / 0.295 in 13 - 15 mm / 0.55 in ④	0.5 - 6 (10) mm ² ① AWG 20 - 8 800 V/8 kV/3 ② I _N 10 A Terminal block width 7.5 mm / 0.295 in 13 - 15 mm / 0.55 in ④
--	--

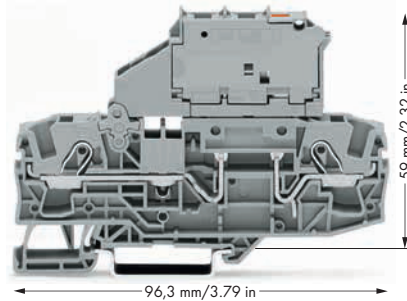
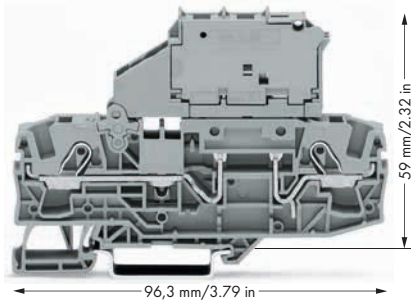

- ① Conductor sizes: 0.5 mm² - 10 mm² "s + f-st"; Push-in conductor sizes: 1 mm² - 10 mm² "s" and 1.5 mm² - 6 mm² "insulated ferrule, 12 mm"
- ② 800 V = rated voltage
8 kV = rated surge voltage
3 = pollution degree
(see Section 14)
- ③ Strip length, see packaging or instructions.
- ④ See application notes for: Star point jumper, page 103

Item No.	Pack. Unit	Item No.	Pack. Unit
2-conductor fuse disconnect terminal block with pivoting fuse holder, without blown fuse indication Both nominal voltage and current are given by the fuse. for miniature fuses 5 x 20 mm		2-conductor fuse disconnect terminal block with pivoting fuse holder, gray, with blown fuse indication by LED Both nominal voltage and current are given by the LED or fuse. Leakage current in case of blown fuse: LED 2mA, for miniature fuses 5 x 20 mm	
gray 2006-1611 25		12 - 30 V 2006-1611/1000-541 25	
		30 - 65 V 2006-1611/1000-542 25	
		120 V 2006-1611/1000-867 25	
		230 V 2006-1611/1000-836 25	
for miniature fuses 5 x 30 mm		for miniature fuses 5 x 30 mm	
gray 2006-1621 25		12 - 30 V 2006-1621/1000-541 25	
		30 - 65 V 2006-1621/1000-542 25	
		120 V 2006-1621/1000-867 25	
		230 V 2006-1621/1000-836 25	
		380 - 500 V 2006-1621/1000-859 25	
for miniature fuses 1/4" x 1 1/4"		for miniature fuses 1/4" x 1 1/4"	
gray 2006-1631 25		12 - 30 V 2006-1631/1000-541 25	
		30 - 65 V 2006-1631/1000-542 25	
		120 V 2006-1631/1000-867 25	
		230 V 2006-1631/1000-836 25	
		380 - 500 V 2006-1631/1000-859 25	

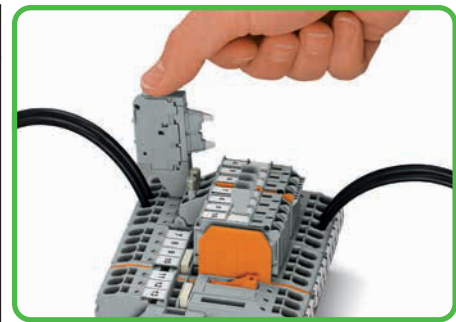

Pivoting the fuse holder in the locked open position.

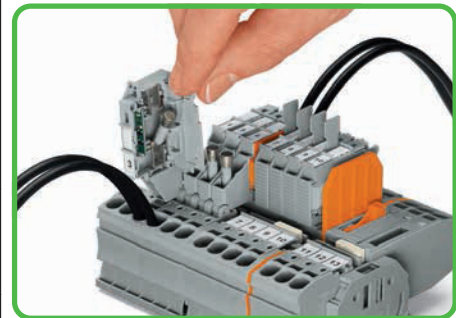

Opening the cover to replace the fuse.

2006 Series Accessories

Appropriate marking systems: WMB/Marking strips (see Section 13)

End and intermediate plate, 1 mm thick orange 2006-1692 100 (4x25) gray 2006-1691 100 (4x25)	Push-in type jumper bar, insulated, I _N 41 A, light gray from 1 to 3 2006-433 50 (2x25) from 1 to 4 2006-434 50 (2x25) from 1 to 5 2006-435 50 (2x25)
End plate for fuse terminal blocks, 2 mm thick orange 2006-992 100 (4x25) gray 2006-991 100 (4x25)	Protective warning marker, with high-voltage symbol, black, for 5 terminal blocks yellow 2006-115 100 (4x25)
Push-in type jumper bar, insulated, I _N 41 A, light gray 2-way 2006-402 50 (2x25) 3-way 2006-403 50 (2x25) 4-way 2006-404 50 (2x25) 5-way 2006-405 50 (2x25)	Test plug, with 500 mm cable, 2 mm Ø red 210-136 50
Star point jumper, insulated, I _N = I _N terminal block, light gray 1-3-5 2006-405/011-000 50 (2x25)	WMB Multi marking system, 10 strips with 10 markers per card, stretchable 5 - 5.2 mm plain 793-5501 5

TOPJOB® S

Fuse Disconnect Terminal Blocks with Pivoting Fuse Holder for Miniature Fuses 1/4" x 1 1/4", 2006 Series

0.5 - 6 (10) mm ² ① AWG 20 - 8 800 V/8 kV/3 ② 600 V, 15 A ③ I _N 10 A Terminal block width 10.4 mm / 0.409 in 13 - 15 mm / 0.55 in ③	0.5 - 6 (10) mm ² ① AWG 20 - 8 800 V/8 kV/3 ② I _N 10 A Terminal block width 10.4 mm / 0.409 in 13 - 15 mm / 0.55 in ③
---	---

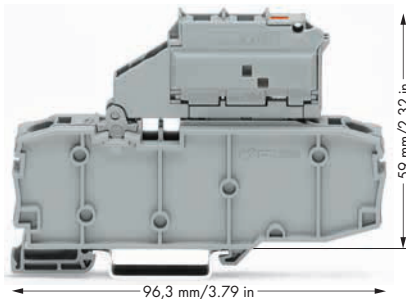
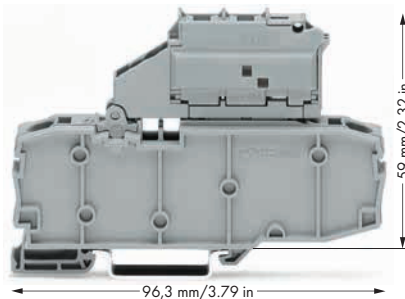

- ① Conductor sizes: 0.5 mm² - 10 mm² "s + f-st"; Push-in conductor sizes: 1 mm² - 10 mm² "s" and 1.5 mm² - 6 mm² "insulated ferrule, 12 mm"
- ② 800 V = rated voltage
8 kV = rated surge voltage
3 = pollution degree
(see Section 14)
- ③ Strip length, see packaging or instructions.
- ④ See application notes for: Star point jumper, page 103

Item No.	Pack. Unit	Item No.	Pack. Unit
Fuse disconnect terminal block with pivoting fuse holder and end plate, without blown fuse indication Both nominal voltage and current are given by the fuse. for miniature fuses 1/4" x 1 1/4"		Fuse disconnect terminal block with pivoting fuse holder and end plate, gray, with blown fuse indication by LED Both nominal voltage and current are given by the LED or fuse. Leakage current in case of blown fuse: LED 2mA, for miniature fuses 1/4" x 1 1/4"	
○ gray	2006-1631/099-000 25	○ 12 - 30 V	2006-1631/1099-541 25
		○ 30 - 65 V	2006-1631/1099-542 25
		○ 120 V	2006-1631/1099-867 25
		○ 230 V	2006-1631/1099-836 25
		○ 380 - 500 V	2006-1631/1099-859 25

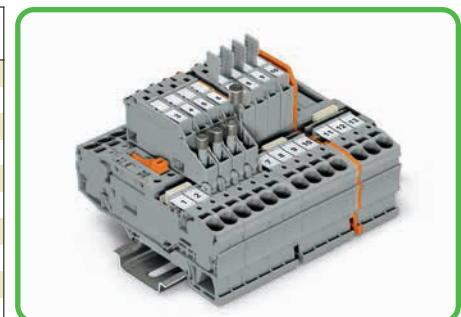

Pivoting fuse holder with spare fuse holders

Protective warning markers must be applied individually. Due to the 10.4 mm width of the fuse terminal blocks with pivoting fuse holder, 2002 Series jumpers must be used.

2006 Series Accessories

Appropriate marking systems: WMB/Marking strips (see Section 13)

End plate for fuse terminal blocks,	Screwless end stop,
2 mm thick orange 2006-992 100 (4x25) gray 2006-991 100 (4x25)	for DIN 35 rail, 6 mm wide gray 249-116 100 (4x25)
Push-in type jumper bar, insulated, I _N 25 A, light gray from 1 to 3 2002-433 200 (8x25) from 1 to 5 2002-435 100 (4x25) from 1 to 7 2002-437 100 (4x25) from 1 to 9 2002-439 100 (4x25)	Screwless end stop, for DIN 35 rail, 10 mm wide gray 249-117 50 (2x25)
Star point jumper, insulated, ④ I _N = I _N terminal block, light gray 1-3-5 2002-405/011-000 100 (4x25)	
Protective warning marker, with high-voltage symbol, black, for 5 terminal blocks yellow 2006-115 100 (4x25)	
WMB Multi marking system, 10 strips with 10 markers per card, stretchable 5 - 5.2 mm plain 793-5501 5	
Test plug, with 500 mm cable, 2 mm Ø red 210-136 50	



Miniature fuses

Series Item No.	Overload and short circuit protection		Short circuit protection only	
	Individual argmt.	Group argmt.	Individual argmt.	Group argmt.
Fused disconnect terminal blocks				
2006-1611	7.5	1.6 W	1.6 W	2.5 W
2006-1621	7.5	1.6 W	1.6 W	2.5 W
2006-1631	7.5	1.6 W	1.6 W	2.5 W
2006-1631 /099...	10.4	2.5 W	2.5 W	2.5 W
2006-1631 /1099...	10.4	2.5 W	2.5 W	2.5 W

When selecting miniature fuses, the maximum power loss listed below should not be exceeded. The power loss is determined according to IEC or EN 60947-3/VEDE 0611-6 at 23°C. The temperature rise of the terminal blocks must be checked according to their application and mounting. Higher ambient temperatures represent an additional impact on miniature fuses. Therefore, in such applications the rated current must be reduced if necessary. More details are available from the fuse manufacturer.

TOPJOB® S

Disconnect Terminal Blocks for Test and Measurement 1500 VDC, Carrier/Through Terminal Blocks of Same Profile 6 (10) mm²/30 A, 2006 Series



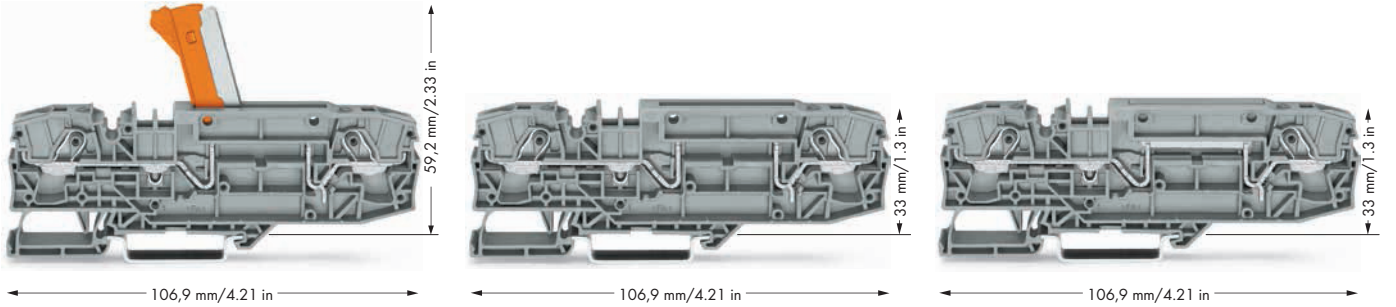





<p>0.5 - 6 (10) mm² ① AWG 20 - 8 AC/DC 1000 V/ DC 1500 V/12 kV/3 ② I_N 30 A</p> <p>Terminal block width 15 mm / 0.591 in  13 - 15 mm / 0.55 in ③</p>	<p>0.5 - 6 (10) mm² ① AWG 20 - 8 AC/DC 1000 V/ DC 1500 V/12 kV/3 ② I_N 30 A</p> <p>Terminal block width 15 mm / 0.591 in  13 - 15 mm / 0.55 in ③</p>	<p>0.5 - 6 (10) mm² ① AWG 20 - 8 AC/DC 1000 V/ DC 1500 V/12 kV/3 ② I_N 30 A</p> <p>Terminal block width 15 mm / 0.591 in  13 - 15 mm / 0.55 in ③</p>
--	---	---



Item No.	Pack. Unit	Item No.	Pack. Unit	Item No.	Pack. Unit
2-conductor disconnect terminal block for test and measurement, with test point, orange disconnect link		2-conductor carrier terminal block, with test point		2-conductor through terminal block, with test point, same profile as 2-conductor disconnect terminal block	
gray 2006-8671	12	gray 2006-8661	12	gray 2006-8601	12
blue 2006-8674	12	blue 2006-8664	12	blue 2006-8604	12
Item-Specific Accessories					
<p>Disconnect plug for carrier terminal blocks, suited when using a carrier terminal block as disconnect terminal block</p>  <p>orange 2006-8401 48 (4x12)</p>					

2006 Series Accessories

Appropriate marking systems: WMB/Marking strips (see Section 13)

<p>End and intermediate plate, 1 mm thick</p>  <p>orange 2006-8692 48 (4x12) gray 2006-8691 48 (4x12)</p>	<p>WMB Multi marking system, 10 strips with 10 markers per card, for terminal widths 5 - 17.5 mm</p>  <p>plain 793-501 5</p>
<p>Protective warning marker, with high-voltage symbol, black, for 5 terminal blocks</p>  <p>yellow 2006-115 100 (4x25)</p>	<p>WMB Multi marking system, plain, 10 strips with 10 markers per card, for terminal widths 5 - 17.5 mm</p>  <p>yellow 793-501/000-002 red 793-501/000-005 blue 793-501/000-006 gray 793-501/000-007 orange 793-501/000-012 light green 793-501/000-017 green 793-501/000-023 violet 793-501/000-024</p>
<p>Push-in type jumper bar, insulated, I_N 41 A, light gray</p>  <p>from 1 to 3 2006-433 50 (2x25) from 1 to 5 2006-435 50 (2x25)</p>	<p>5</p>
<p>Lockout cap, for conductor entry hole and operating slot</p>  <p>gray 2006-191 25</p>	<p>Marking strip, plain, 11 mm wide, 50 m roll</p>  <p>white 2009-110 1</p>
	<p>WMB Inline, plain, stretchable 5 - 5.2 mm, 1,500 WMB markers, 5 mm, on roll</p>  <p>white 2009-115 1</p>

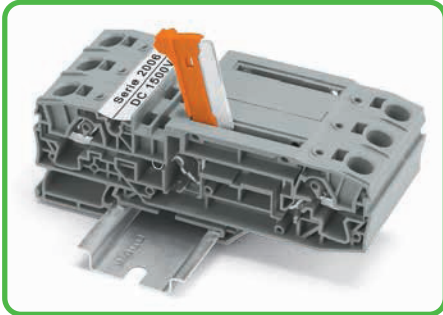

Disconnect/test terminal block with knife disconnect (2006-8671) in disconnect position

Both 2006-8671 and 2006-8661 TOPJOB® S disconnect terminal blocks have been specially designed for use in photovoltaic and wind power systems, where voltages exceeding 1,000 V (IEC) and 600 V (UL) are required (e.g., generator junction boxes).

- Ideal for high voltages in renewable energy applications
- **Disconnect terminal blocks with two alternative disconnect options:**
with orange knife disconnect (2006-8671)
with orange disconnect plug (2006-8661)
- This 2006 Series terminal blocks are approved for 30 A/1,500 VDC (IEC) or 1,000 VDC (UL)
- With a terminal block width of 15 mm, the maximum cross-section for solid and fine-stranded conductors is 10 mm² (AWG 8) and 6 mm² (AWG 10) for ferruled conductors.
- Equipped with test slots
- Compatible with through terminal blocks of the same profile and all other TOPJOB® S terminal blocks

① Conductor sizes: 0.5 mm² - 10 mm² "s + f-st";
 Push-in conductor sizes: 1 mm² - 10 mm² "s"
 and 1.5 mm² - 6 mm²
 "insulated ferrule, 12 mm"

② AC/DC 1000 V = rated voltage
 DC 1500 V
 12 kV = rated surge voltage
 3 = pollution degree
 (see Section 14)

③ Strip length, see packaging or instructions.

④ Protective warning marker must be applied individually.

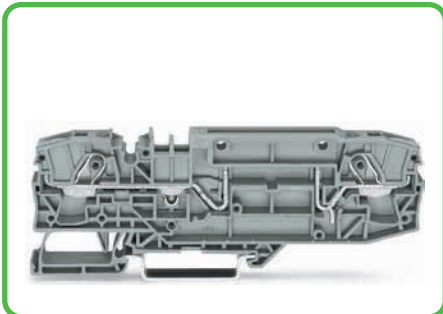

Carrier terminal block (2006-8661) with receptacle for orange disconnect plug

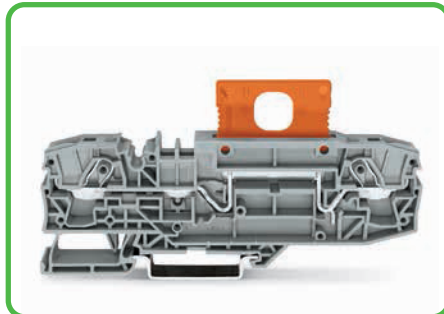

Orange disconnect plug (2006-8401) in operating position

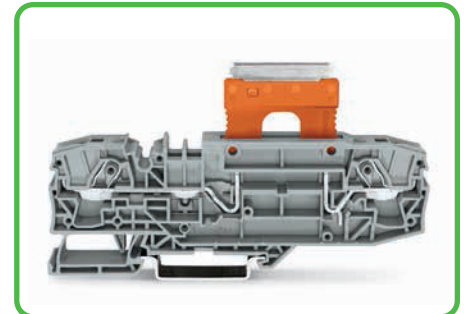

Orange disconnect plug (2006-8401) in parked position

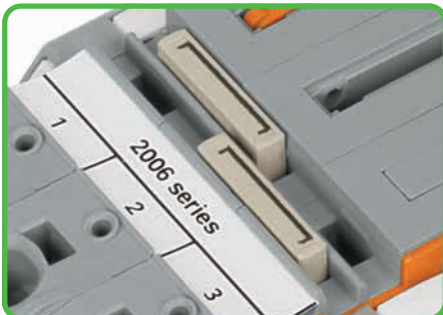

Commoning a 15 mm wide terminal block via push-in type jumper bars: 1 to 3 (2006-433) and 1 to 5 (2006-435).

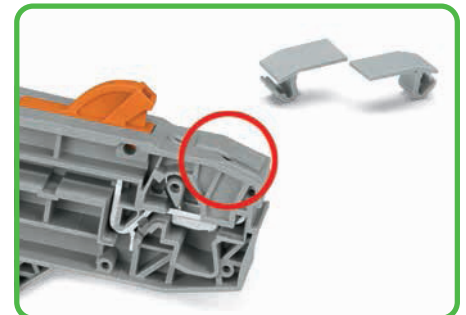

Cover seals unused conductor entry.

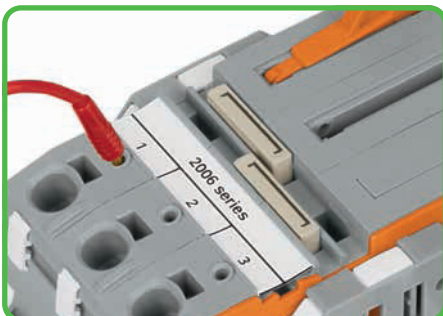

Test slots on both terminal block sides allow for direct measurement.

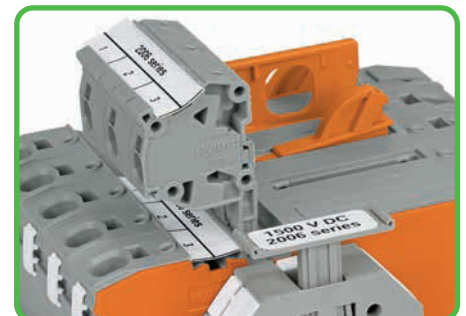

Alternatively, measurement can also be performed using TOPJOB® S connectors (2006-511) from terminal block 1 to 2. Spacer modules (2006-549) must be used to compensate for the 15 mm terminal block width.

TOPJOB® S 2007-8821 Current Transformer Terminal Blocks (Orange Disconnect Link)

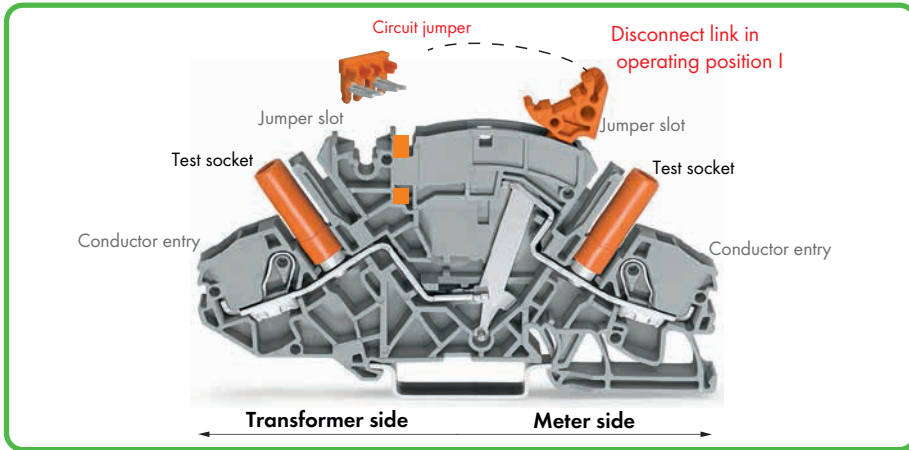

The TOPJOB® S current transformer (disconnect/test) terminal block (2007-8821) has been specially designed for current and voltage transformer circuits to measure the current transformer's operability.

First, the current transformer is shorted via disconnect link and circuit jumper (insert jumper, move disconnect link from operation position I to shorting position II, activate shorting path). Connecting a measuring device via test socket on the meter side can only be performed once circuit disconnection is complete (disconnect link in measuring position III).

- Features top-of-unit circuit jumper slot for shorting path activation.
- Disconnect link provides intuitive and easy operation, as well as exact switching status indication.
- Combines high functionality with compact design (99.6 mm long and 8 mm wide).
- All 2007 Series terminal blocks are rated 30 A/500 V (IEC) and 300 V (UL).
- With a terminal block width of 8 mm, the maximum cross-section for solid and fine-stranded conductors is 10 mm² (AWG 8) and 6 mm² (AWG 10) for ferruled conductors.
- Touch-proof test sockets for 4 mm Ø test plugs on transformer and meter side.
- Compatible with through and ground conductor terminal blocks of same profile.

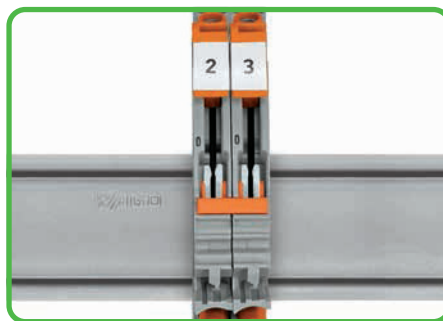
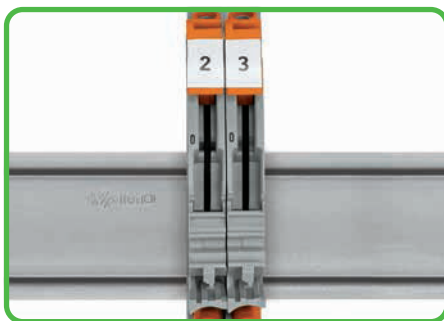
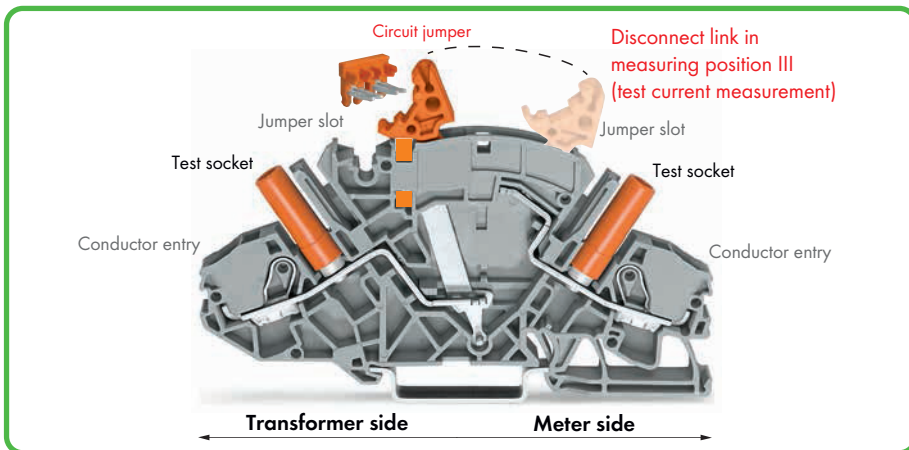
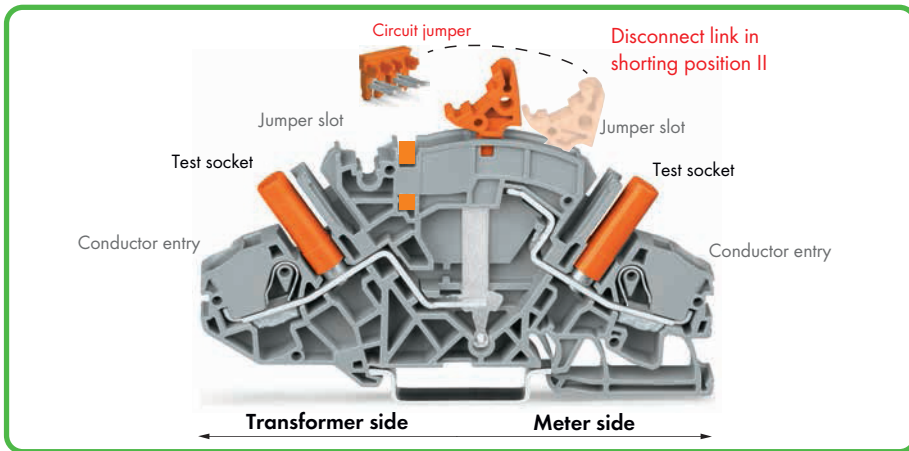

Preparing the shorting path for current transformer circuits

Inserting insulated, touch-proof circuit jumpers into jumper slot. Using locking covers or profiles for adjacent terminal blocks allows disconnect links to be operated simultaneously.



CAGE CLAMP® S
clamps the following
copper conductors:*

solid



stranded



fine-stranded,
also with tinned
single strands

* For aluminum conductors, see notes in Section 14.

TOPJOB® S

Implementing a Current and Voltage Transformer Circuit

Disconnect link in operating position I

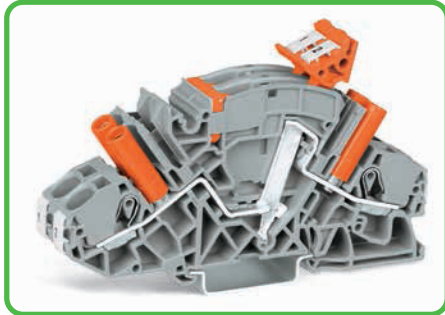

Terminal blocks required:
 2 x disconnect/test terminal block 2007-8821
 1 x circuit jumper, orange 2007-8442
 optional with locking covers or interlocking links

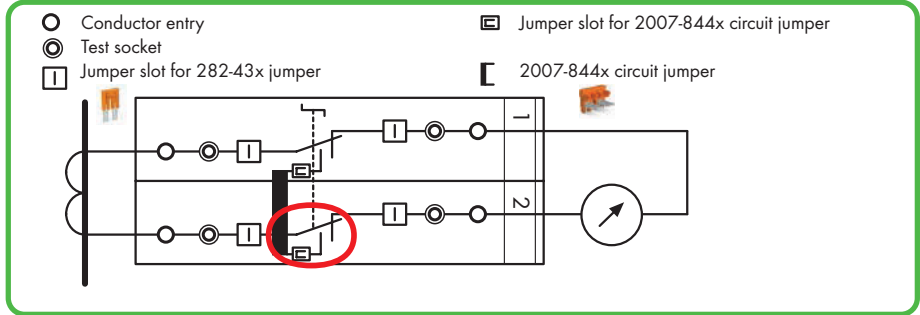

In operating position, the measuring device is connected to the transformer, the circuit jumper is inserted and the disconnect link is in position I.

Disconnect link in shorting position II

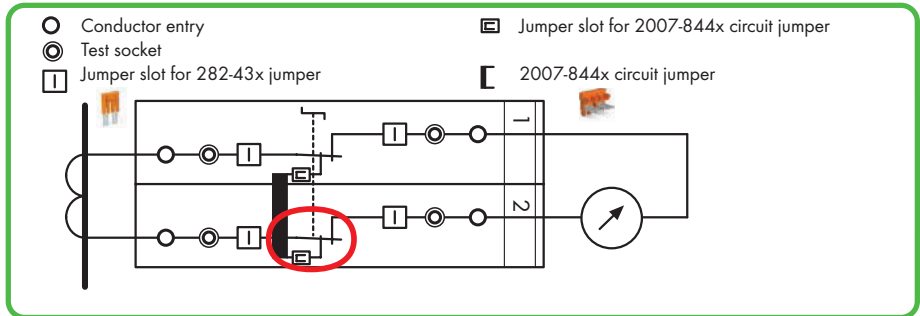
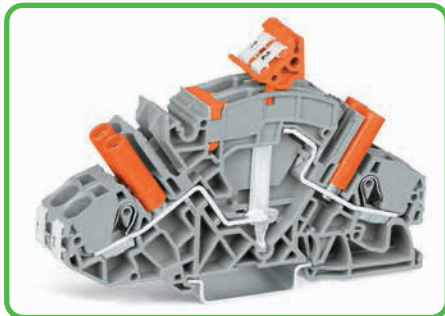

The transformer is **not** disconnected from the measuring device yet, the shorting path is activated by moving the disconnect link into shorting position II and the transformer is safely shorted.

Measuring, disconnect link in measuring position III / test current measurement

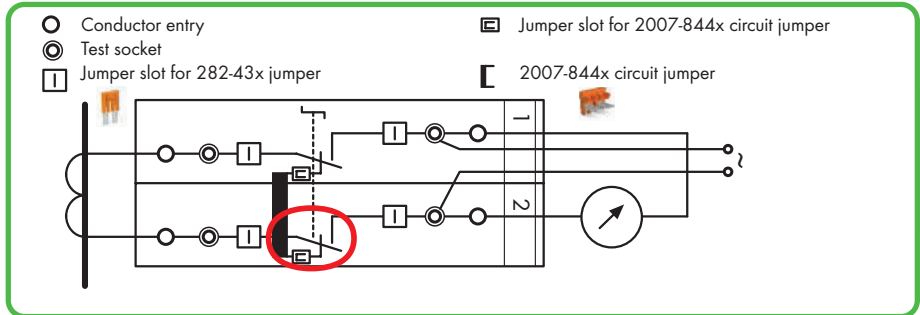
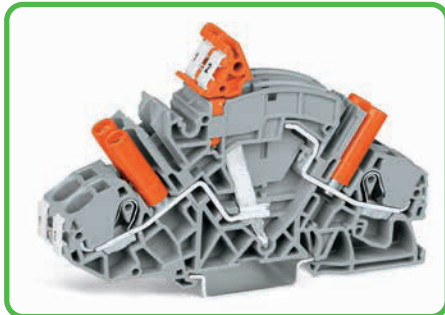

The measuring device/relay is electrically disconnected from the transformer. If required, an external voltage can be applied to the measuring device/relay via the test socket.

Measurement testing via both test sockets

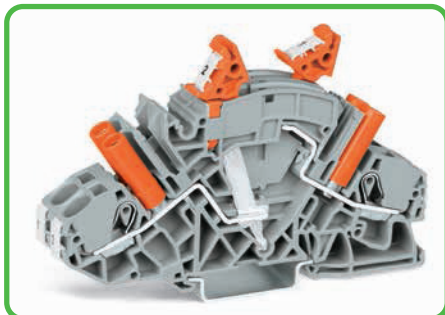

Terminal block 1: Disconnect link in operating position I
 Terminal block 2: Disconnect link in measuring position III

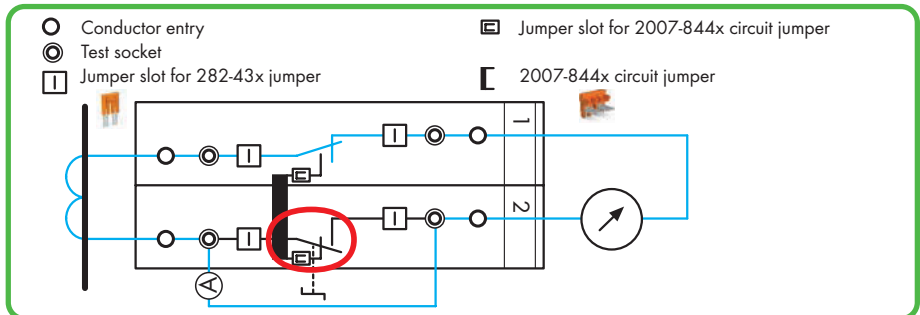

Measurement testing: First insert the reference current meter (A) into the test socket, then move the disconnect link into measurement position III (test current measurement).



fine-stranded, tip-bonded



fine-stranded, with ferrule (gastight crimped)



fine-stranded, with pin terminal (gastight crimped)

Examples for Current Transformer Circuits

70 Measuring set for a 3-phase current transformer

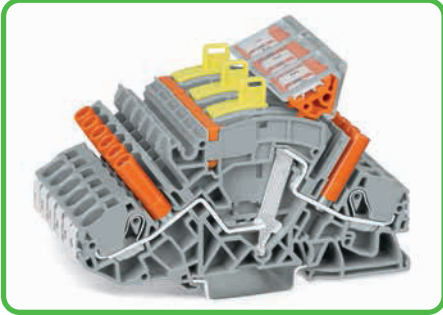

Terminal blocks required:
 6 x disconnect/test terminal block 2007-8821
 3 x circuit jumper, orange 2007-8442
 In addition: interlocking links, locking covers, lock-outs

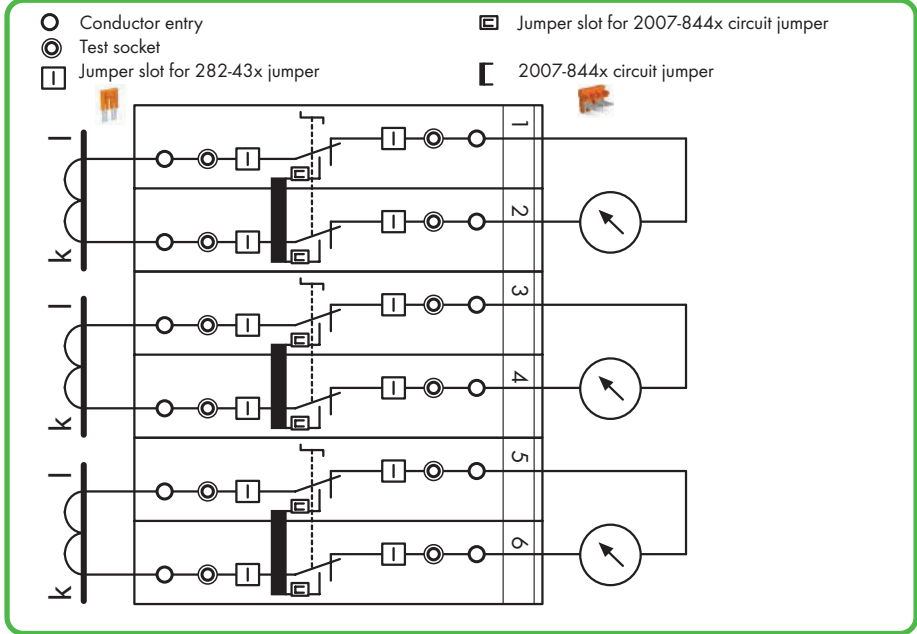

Pairs of disconnect links are interconnected via locking covers or interlocking links. Measurement testing is performed after the interlocking is released.

Measuring set for a 3-phase current transformer with 'Y' point

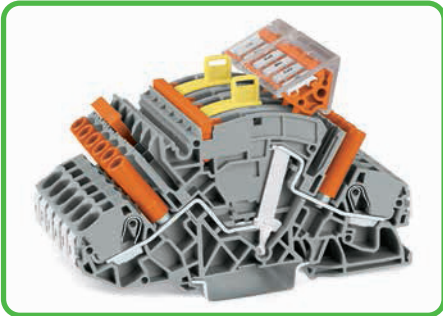

Terminal blocks required:
 6 x disconnect/test terminal block 2007-8821
 1 x circuit jumper, orange 2007-8446
 1 x jumper, orange 282-433
 In addition: interlocking links, locking covers, lock-outs

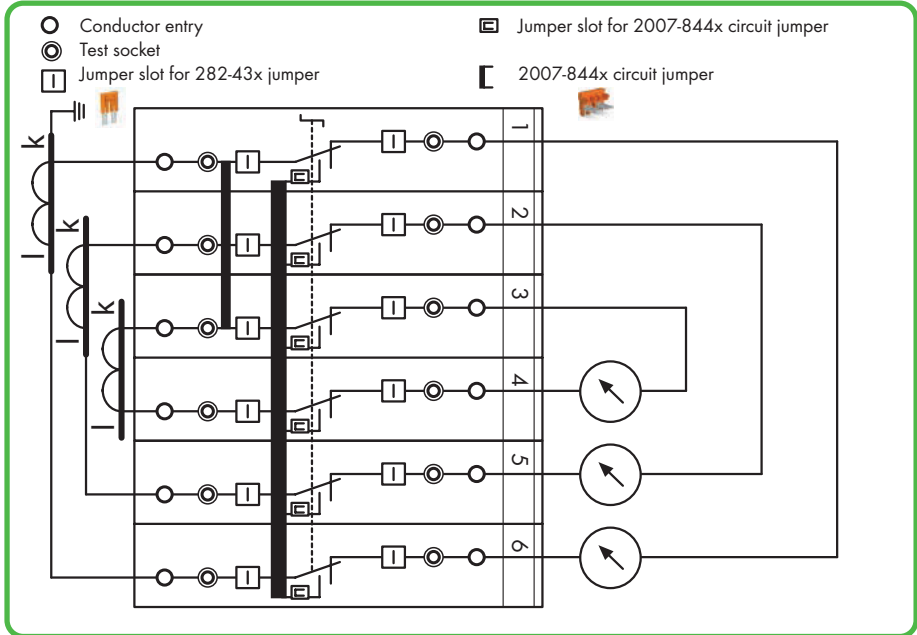

All 6 disconnect links are interconnected via via locking covers or interlocking links.

TOPJOB® S 2007-8811 Voltage Transformer Terminal Blocks (Light Gray Disconnect Link)

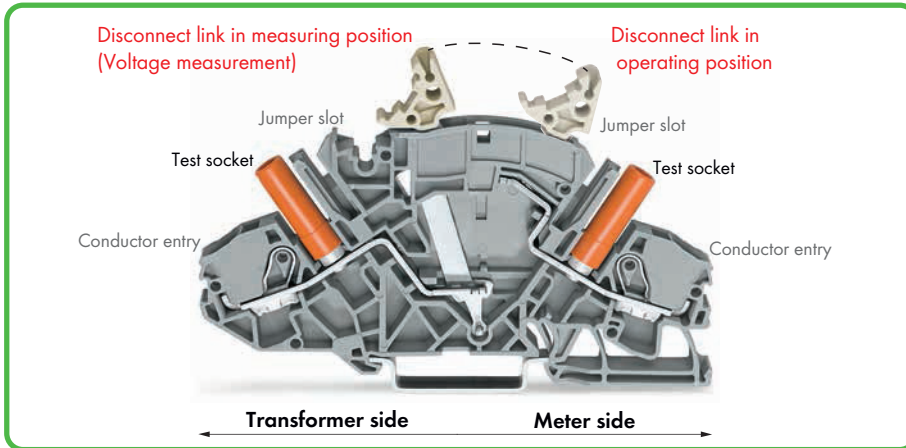

The TOPJOB® S voltage transformer (disconnect/test) terminal block (2007-8811) has been specially designed for voltage transformer circuits.

First, the voltage transformer must be disconnected from the circuit (from operating position to measuring position). Connecting a measuring device via test socket on the meter side can only be performed once circuit disconnection is completed (measuring position).

- For voltage transformer circuits (no circuit jumper slot required as for current transformer terminal block 2007-8821).
- Disconnect link provides intuitive and easy operation, as well as exact switching status indication.
- Combines high functionality with compact design (99.6 mm long and 8 mm wide).
- All 2007 Series terminal blocks are rated at 30 A/500 V (IEC) and 300 V (UL).
- With a terminal block width of 8 mm, the maximum cross-section for solid and fine-stranded conductors is 10 mm² (AWG 8) and 6 mm² (AWG 10) for ferruled conductors.
- Touch-proof test sockets for 4 mm Ø test plugs on transformer and meter side.
- Compatible with through and ground conductor terminal blocks of same profile.

Example for voltage transformer testing Measuring set for single-phase voltage transformer testing



Terminal blocks required:
 1 x disconnect/test terminal block 2007-8811
 1 x through terminal block 2007-8801
 1 x end plate, orange 2007-8892
 In addition: locking cover, lock-out

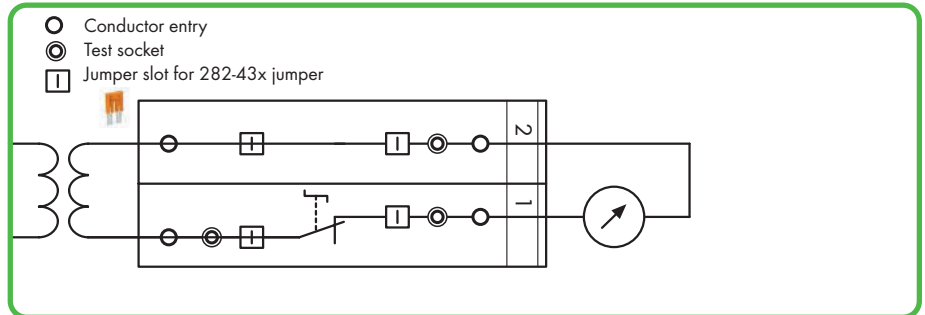

Disconnecting the voltage transformer from the circuit: Move disconnect link from operating position to measuring position.
 Voltage measurement: Connecting a measuring device via test socket on the meter side can only be performed after disconnection is completed (measuring position).

Marking

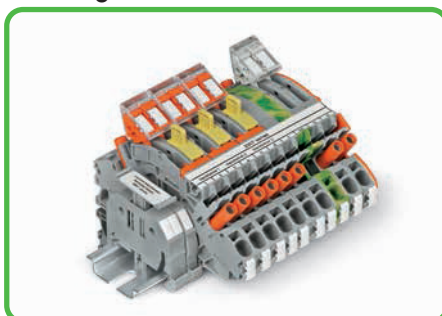

Marking via WMB Multi markers or marking strips.

Commoning



Additional commoning option via circuit-related jumpers or testing via test plug adapters (209-170) on transformer side



Locking cover for disconnect links





Multipole switching via snap-on type, transparent (locking) cover for disconnect links.

TOPJOB® S

Disconnect Terminal Blocks for Test and Measurement, 6 mm²/30 A, for Current and Voltage Transformer Circuits, 2007 Series

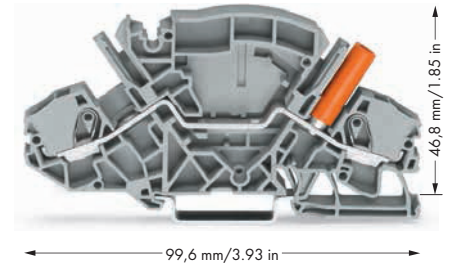
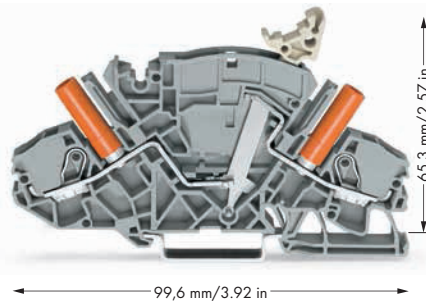
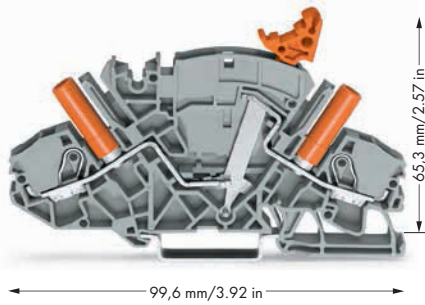
<p>0.5 - 6 (10) mm² ① AWG 20 - 8 500 V/6 kV/3 ② I_N 30 A</p> <p>Terminal block width 8 mm / 0.315 in  13 - 15 mm / 0.55 in ③</p>	<p>0.5 - 6 (10) mm² ① AWG 20 - 8 500 V/6 kV/3 ② I_N 30 A</p> <p>Terminal block width 8 mm / 0.315 in  13 - 15 mm / 0.55 in ③</p>	<p>0.5 - 6 (10) mm² ① AWG 20 - 8 500 V/6 kV/3 ② I_N 30 A</p> <p>Terminal block width 8 mm / 0.315 in  13 - 15 mm / 0.55 in ③</p>
--	---	---



Item No.	Pack. Unit	Item No.	Pack. Unit	Item No.	Pack. Unit
2-conductor disconnect terminal block for test and measurement , e.g., current transformer circuits, with receptacle for adjacent jumper with switch lever, with touch-proof test sockets, for 4 mm Ø test plug gray 2007-8821 20		2-conductor disconnect terminal block for test and measurement , e.g., voltage transformer circuits, with touch-proof test sockets, for 4 mm Ø test plug gray 2007-8811 20		2-conductor through terminal block , with touch-proof test socket, for 4 mm Ø test plug gray 2007-8801 20	
Item-Specific Accessories					
Adjacent jumper for switch lever , insulated, orange, I _N 30 A					
	2-way	2007-8442	50 (5x10)		
	3-way	2007-8443	50 (5x10)		
	4-way	2007-8444	50 (5x10)		
	5-way	2007-8445	50 (5x10)		
	6-way	2007-8446	50 (5x10)		
	7-way	2007-8447	50 (5x10)		
	8-way	2007-8448	50 (5x10)		

2006 Series Accessories

Appropriate marking systems: WMB/Marking strips (see Section 13)

End and separator plate , 1.5 mm thick, without use of lock-out seal orange 2007-8892 50 (5x10) gray 2007-8891 50 (5x10)	Jumper , insulated, I _N 30 A, orange 2-way 282-432 50 (5x10) 3-way 282-433 50 (5x10) 4-way 282-434 50 (5x10) 5-way 282-435 50 (5x10) 6-way 282-436 50 (5x10) 7-way 282-437 50 (5x10) 8-way 282-438 50 (5x10) 9-way 282-439 50 (5x10) 10-way 282-440 50 (5x10)	Jumper , special design, I _N 30 A, orange 1-3-5 282-435/011-000 1-2-4-6 282-436/301-000 1-3-5-7 282-437/011-000 1-4-7 282-437/012-000 1-2-5-8 282-438/300-000 1-4-7-8 282-438/301-000 1-3-5-7-9 282-439/011-000 50 (5x10)
End and separator plate , 1.5 mm thick, for use of lock-out seal orange 2007-8894 50 (5x10) gray 2007-8893 50 (5x10)	Jumper with safety lid , insulated, I _N 30 A, orange 2-way 282-432/100-000 3-way 282-433/100-000 4-way 282-434/100-000 50 (5x10)	Protective warning marker , with high-voltage symbol, black, for 5 terminal blocks yellow 2006-115 100 (4x25)
Lock-out , for disconnect link yellow 2007-8899 100 (5x20)	Interlocking link , mechanically locks multiple links, 1 m/3'3" long transparent 210-254 1	WMB Multi marking system , 10 strips with 10 markers per card, for terminal widths 5 - 17.5 mm plain 793-501 5
Locking cover , transparent, mechanically locks multiple links 1-pole 282-881 50 (5x10) 2-pole 282-882 50 (5x10) 3-pole 282-883 50 (5x10) 4-pole 282-884 50 (5x10) 5-pole 282-885 50 (5x10) 6-pole 282-886 50 (5x10) 7-pole 282-887 50 (5x10) 8-pole 282-888 50 (5x10)		Marking strip , plain, 11 mm wide, 50 m roll white 2009-110 1

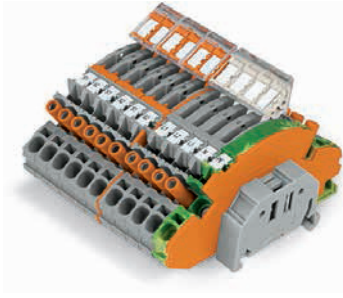
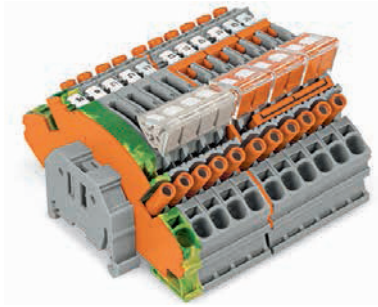

Item No. for 2007-8873	Description	Quantity
249-117	Screwless end stop, 10 mm wide	2
282-882	Locking cover, mechanically locks multiple links, 2-pole	3
282-884	Locking cover, mechanically locks multiple links, 4-pole	1
2007-8442	Adjacent jumper for switch lever, insulated, 2-way	3
2007-8807	2-conductor ground terminal block, with touch-proof test socket, for 4 mm Ø test plug	1
2007-8811	2-conductor disconnect terminal block for test and measurement, with touch-proof test sockets, for 4 mm Ø test plug	4
2007-8821	2-conductor disconnect terminal block for test and measurement, with touch-proof test sockets, for 4 mm Ø test plug	6
2007-8892	End and separator plate, 1.5 mm thick, without use of lock-out seal	2
209-135	WMB Inline, plain, stretchable 5 - 5.2 mm, 8,000 WMB markers, 5 mm, on roll	21 Markers
282-435/011-000	Jumper, insulated, 1-3-5	1
Assembly width incl. end stop		11.2 cm

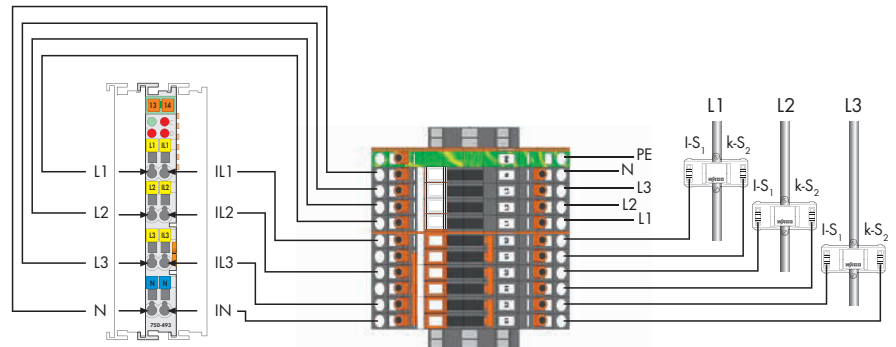

3-Phase Power Measurement Module
750 Series

Terminal Block Assembly for
Current and Voltage Transformers
2007 Series

Current Transformers
855 Series



Item No. for 2007-8876	Quantity
Description	
249-117 Screwless end stop, 10 mm wide	2
282-369 Collective carrier for jumpers, for DIN 35 rail, for jumpers for transverse switching terminal block (282-811) and longitudinal switching disconnect terminal block (282-821)	1
282-882 Locking cover, mechanically locks multiple links, 2-pole	3
2007-8442 Adjacent jumper for switch lever, insulated, 2-way	3
2007-8821 2-conductor disconnect terminal block for test and measurement, with touch-proof test sockets, for 4 mm Ø test plug	6
2007-8892 End and separator plate, 1.5 mm thick, without use of lock-out seal	1
2009-135 WMB Inline, plain, stretchable 5 - 5.2 mm, 8,000 WMB markers, 5 mm, on roll	12 Markers
282-435/011-000 Jumper, insulated, 1-3-5	1
Assembly width incl. end stop	8.5 cm

TOPJOB® S

2004 Series Fuse Plugs on 2002 Series Carrier Terminal Blocks

<p>Fuse plug with pull-tab for miniature fuses 5 x 20 mm 250 V / I_N 6.3 A Plug width 6.1 mm / 0.24 in</p>	<p>Fuse plug with pull-tab for miniature fuses 5 x 20 mm 250 V / I_N 6.3 A Plug width 6.1 mm / 0.24 in</p>
--	--

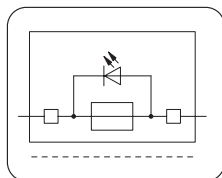
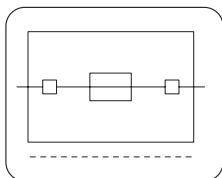

Accessories	
WMB Multi marking system,	
	10 strips with 10 markers per card, stretchable 5 - 5.2 mm plain 793-5501 5
WMB Multi marking system, plain,	
	10 strips with 10 markers per card, stretchable 5 - 5.2 mm
yellow	793-5501/000-002
red	793-5501/000-005
blue	793-5501/000-006
gray	793-5501/000-007
orange	793-5501/000-012
light green	793-5501/000-017
green	793-5501/000-023
violet	793-5501/000-024
5	

Item No.	Pack. Unit	Item No.	Pack. Unit
Fuse plug with pull-tab, for miniature fuses 5 x 20 mm Both nominal voltage and current are given by the fuse.		Fuse plug with pull-tab, for miniature fuses 5 x 20 mm, with indicator lamp, gray Both nominal voltage and current are given by the LED or fuse. Leakage current in case of blown fuse: LED 2mA	
● gray	2004-911 50	● 12 - 30 V	2004-911/1000-541 50
		● 30 - 65 V	2004-911/1000-542 50
		● 120 V	2004-911/1000-867 50
		● 230 V	2004-911/1000-836 50

Accessories	
Appropriate marking systems: WMB/Marking strips (see Section 13)	
2-conductor carrier terminal block, ① 0.25 - 2.5 (4) mm ² / AWG 22 - 12 Terminal block width 5.2 mm / 0.205 in gray 2002-1661 50	2-conductor carrier terminal block, ④ 0.25 - 2.5 (4) mm ² / AWG 22 - 12 Terminal block width 5.2 mm / 0.205 in gray 2002-1961 50
End and intermediate plate, 1 mm thick orange 2002-1692 100 (4x25) gray 2002-1691 100 (4x25)	End and intermediate plate, 1 mm thick orange 2002-1992 100 (4x25) gray 2002-1991 100 (4x25)
3-conductor carrier terminal block, ② 0.25 - 2.5 (4) mm ² / AWG 22 - 12 Terminal block width 5.2 mm / 0.205 in gray 2002-1761 50	Double-deck carrier terminal block, 0.25 - 2.5 (4) mm ² / AWG 22 - 12 Terminal block width 5.2 mm / 0.205 in L/L 2002-2961 50
End and intermediate plate, 1 mm thick orange 2002-1792 100 (4x25) gray 2002-1791 100 (4x25)	Double-deck carrier terminal block, 0.25 - 2.5 (4) mm ² / AWG 22 - 12 Terminal block width 5.2 mm / 0.205 in L/N 2002-2963 50
4-conductor carrier terminal block, ③ 0.25 - 2.5 (4) mm ² / AWG 22 - 12 Terminal block width 5.2 mm / 0.205 in gray 2002-1861 50	End and intermediate plate, 1 mm thick orange 2002-2992 100 (4x25) gray 2002-2991 100 (4x25)
End and intermediate plate, 1 mm thick orange 2002-1892 100 (4x25) gray 2002-1891 100 (4x25)	End plate for fuse terminal blocks, 2 mm thick orange 2002-992 100 (4x25) gray 2002-991 100 (4x25)
	Shorting link, 5 x 20 mm, if the fuse plug is used as disconnect plug I _N 6.3 A 281-503 250 (10x25)

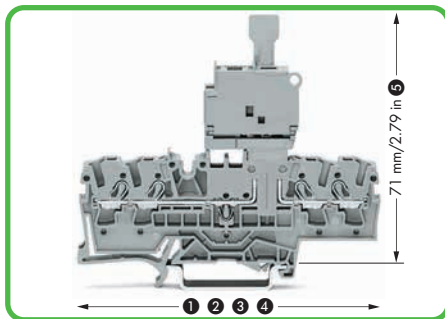

Fuse plug dimensions:

- 1 66.5 mm/2.62 in for 2002-1661
- 2 76.8 mm/3.02 in for 2002-1761
- 3 87.5 mm/3.45 in for 2002-1861
- 3 72.9 mm/2.87 in for 2002-1961
- 4 with inserted fuse plug

Using pluggable fuse holders with rail-mount terminal blocks for control circuit protection is highly advantageous for the user since the function and the wiring are accomplished by two separate parts:

- No additional cost for assembly and wiring
- No risk of accidental contact with live parts during disconnection of fuse plug
- If exchanging a defective fuse, the fuse plug is completely separated from the carrier terminal block. This provides safe fuse changeout away from current carrying parts.
- The fuse plug can be removed by service personnel, avoiding unintentional reclosing of the circuit by another person.
- Quick replacement a fuse by using a prepared "stand-by plug."

The following fuse plug features provide quick and safe handling:

- Optional LED indicates blown fuse
- Marking slot on the fuse plug for clear coordination to the correct carrier terminal block
- Two touch-proof test slots
- High density with only 6.1 mm width of terminal block/ fuse plug
- Instead of a fuse, a shorting link may be used as a disconnect plug.

Miniature fuses 5 x 20

Series Item No.	Overload and short circuit protection		Short circuit protection only	
	Individual argmt.	Group argmt.	Individual argmt.	Group argmt.
Fuse terminal blocks				
2004-911				
2004-911/.....	1.6 W	1.6 W	2.5 W	2.5 W

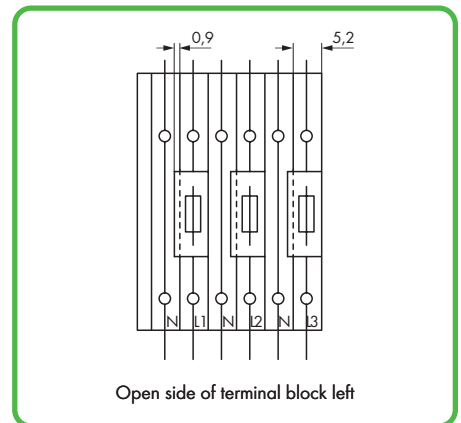

Please note:

The extra width of the plug (6.1 mm compared to 5.2 mm for carrier terminal blocks) must be compensated for by intermediate plates (1 mm) when building an assembly of carrier terminal blocks equipped with fuse plugs.

TOPJOB® S

Fuse Plugs on Carrier Terminal Blocks 6 (10) mm²

2006 Series

Fuse plug with pull-tab 800 V / I _N 10 A Plug width 7.4 mm / 0.291 in	Fuse plug with pull-tab 800 V / I _N 10 A Plug width 7.4 mm / 0.291 in	Fuse plug with pull-tab 800 V / I _N 10 A Plug width 10.4 mm / 0.409 in
---	---	--

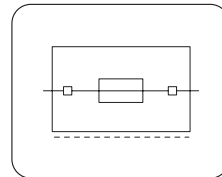
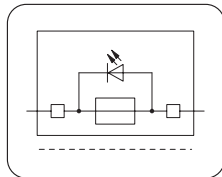
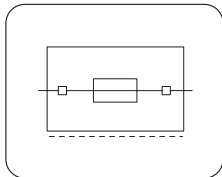

Item No.	Pack. Unit	Item No.	Pack. Unit	Item No.	Pack. Unit
Fuse plug with pull-tab Both nominal voltage and current are given by the fuse. for miniature fuses 5 x 20 mm		Fuse plug with pull-tab, gray, with indicator lamp Both nominal voltage and current are given by the LED or fuse. Leakage current in case of blown fuse: LED 2mA, for miniature fuses 5 x 20 mm		Fuse plug with pull-tab Both nominal voltage and current are given by the fuse. for miniature fuses 1/4" x 11/4"	
● gray	2006-911	25	● 12 - 30 V 2006-911/1000-541 25 ● 30 - 65 V 2006-911/1000-542 25 ● 120 V 2006-911/1000-867 25 ● 230 V 2006-911/1000-836 25	● gray	2006-931/099-000 25
for miniature fuses 5 x 30 mm		for miniature fuses 5 x 30 mm			
● gray	2006-921	25	● 12 - 30 V 2006-921/1000-541 25 ● 30 - 65 V 2006-921/1000-542 25 ● 120 V 2006-921/1000-867 25 ● 230 V 2006-921/1000-836 25 ● 380 - 500 V 2006-921/1000-859 25		
for miniature fuses 1/4" x 11/4"		for miniature fuses 1/4" x 11/4"			
● gray	2006-931	25	● 12 - 30 V 2006-931/1000-541 25 ● 30 - 65 V 2006-931/1000-542 25 ● 120 V 2006-931/1000-867 25 ● 230 V 2006-931/1000-836 25 ● 380 - 500 V 2006-931/1000-859 25		
Item-Specific Accessories		Item-Specific Accessories		Item-Specific Accessories	
End and intermediate plate, 1 mm thick orange 2006-1692 100 (4x25) gray 2006-1691 100 (4x25)		End and intermediate plate, 1 mm thick orange 2006-1692 100 (4x25) gray 2006-1691 100 (4x25)		Intermediate plate, 2.9 mm thick orange 2006-1696 100 (4x25) gray 2006-1695 100 (4x25)	
Accessories fuse plugs Appropriate marking systems: WMB/Marking strips (see Section 13)					
End plate for fuse terminal blocks, 2 mm thick orange 2006-992 100 (4x25) gray 2006-991 100 (4x25)		Shorting link, 5 x 20 mm, if the fuse plug is used as disconnect plug I _N 6.3 A 281-503 250 (10x25)		Screwless end stop, for DIN 35 rail, 6 mm wide gray 249-116 100 (4x25)	
2-conductor carrier terminal block, 0.5 - 6 (10) mm ² / AWG 20 - 8 Terminal block width 7.5 mm / 0.295 in gray 2006-1661 25		WMB Multi marking system, 10 strips with 10 markers per card, stretchable 5 - 5.2 mm plain 793-5501 5		Screwless end stop, for DIN 35 rail, 10 mm wide gray 249-117 50 (2x25)	

Certification organizations can be found in the overview on pages 622 and 623.

Fuse plug with pull-tab

800 V / I_N 10 A
Plug width 10.4 mm / 0.409 in



Using pluggable fuse holders with rail-mounted terminal blocks for control circuit protection is highly advantageous for the user, as the function and the wiring are accomplished by two separate parts:

- No additional cost for assembly and wiring
- No risk of accidental contact with live parts during disconnection of fuse plug
- If exchanging a defective fuse, the fuse plug is completely separated from the carrier terminal block. This provides changeout away from current carrying parts.
- The fuse plug can be removed by service personnel, avoiding unintentional reclosing of the circuit by another person
- Quick replacement a fuse by using a prepared "stand-by plug."

The following features of the fuse plug ensure quick and safe use:

- Optional LED indicates blown fuse
- Markable fuse plug for clear coordination to the correct carrier terminal block
- Two touch-proof test slots
- High density with only 7.5 mm width of terminal block and fuse plug width 7.4 (10.4) mm
- Instead of a fuse, a shorting link may be used as a disconnect plug

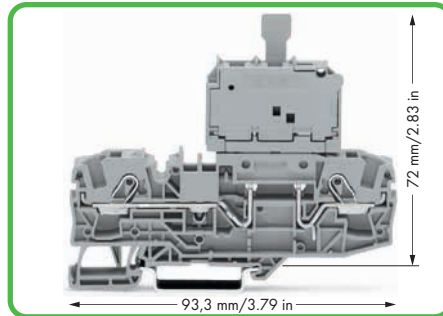
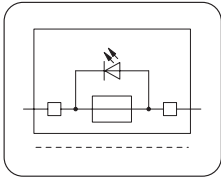

Fuse plug dimensions

Miniature fuses

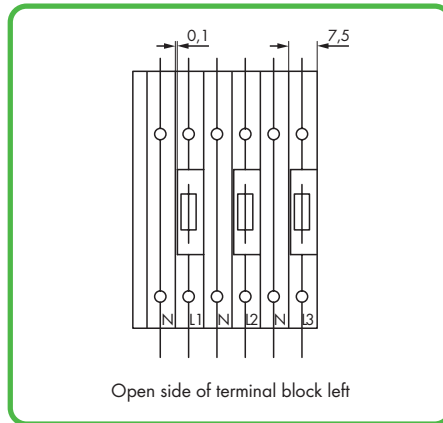

Series Item No.	Overload and short circuit protection		Short circuit protection only		
	Individual argmt.	Group argmt.	Individual argmt.	Group argmt.	
Fused disconnect terminal blocks					
2006-911	7.5	1.6 W	1.6 W	2.5 W	2.5 W
2006-921	7.5	1.6 W	1.6 W	2.5 W	2.5 W
2006-931	7.5	1.6 W	1.6 W	2.5 W	2.5 W
2006-931 /099...	10.4	2.5 W	2.5 W	2.5 W	2.5 W
2006-931 /1099...	10.4	2.5 W	2.5 W	2.5 W	2.5 W

Item No.	Pack. Unit
Fuse plug with pull-tab, gray, with indicator lamp	
Both nominal voltage and current are given by the LED or fuse. Leakage current in case of blown fuse: LED 2mA, for miniature fuses 1/4" x 11/4"	
○ 12 - 30 V	2006-931/1099-541 25
○ 30 - 65 V	2006-931/1099-542 25
○ 120 V	2006-931/1099-867 25
○ 230 V	2006-931/1099-836 25
○ 380 - 500 V	2006-931/1099-859 25



Open side of terminal block left

Item-Specific Accessories

Intermediate plate, 2.9 mm thick			
	orange	2006-1696	100 (4x25)
	gray	2006-1695	100 (4x25)

When using the 10.4 mm wide plug, please note:

The extra width of the plug (10.4 mm compared to 7.5 mm for carrier terminal blocks) must be compensated for by intermediate plates (2.9 mm) when building an assembly of carrier terminal blocks equipped with fuse plugs.

TOPJOB® S

Diode Terminal Blocks and LED Terminal Blocks 1.5 (2.5) mm²

2001 Series

<p>0.25 - 1.5 (2.5) mm² ① AWG 22 - 14 U_N 250 V, U_{RM} 1000 V 1N4007 - 0.5 A continuous current Terminal block width 4.2 mm / 0.165 in 9 - 11 mm / 0.39 in ②</p>	<p>0.25 - 1.5 (2.5) mm² ① AWG 22 - 14 U_N 250 V, U_{RM} 1000 V 1N4007 - 0.5 A continuous current Terminal block width 4.2 mm / 0.165 in 9 - 11 mm / 0.39 in ②</p>	<p>0.25 - 1.5 (2.5) mm² ① AWG 22 - 14 24 VDC I_F 0.025 A max. Terminal block width 4.2 mm / 0.165 in 9 - 11 mm / 0.39 in ②</p>
--	--	---

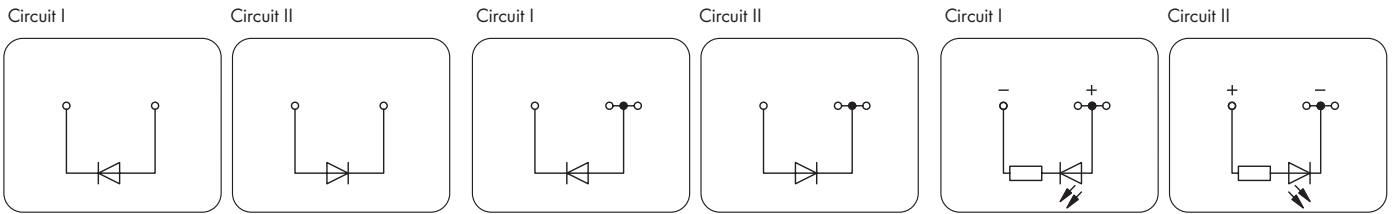
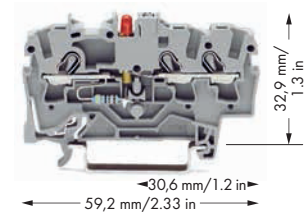
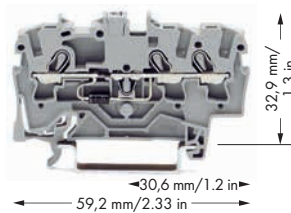
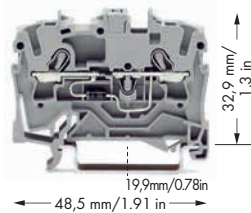

Item No.	Pack. Unit	Item No.	Pack. Unit	Item No.	Pack. Unit
2-conductor diode terminal block with 1N4007 diode, gray		3-conductor diode terminal block with 1N4007 diode, gray		3-conductor LED terminal block with red LED, 24 VDC, gray Notice: This LED terminal block cannot be commoned with push-in type jumper bars!	
○ Circuit I	2001-1211/1000-411 100	○ Circuit I	2001-1311/1000-411 100	○ Circuit I	2001-1321/1000-413 100
○ Circuit II	2001-1211/1000-410 100	○ Circuit II	2001-1311/1000-410 100	○ Circuit II	2001-1321/1000-434 100

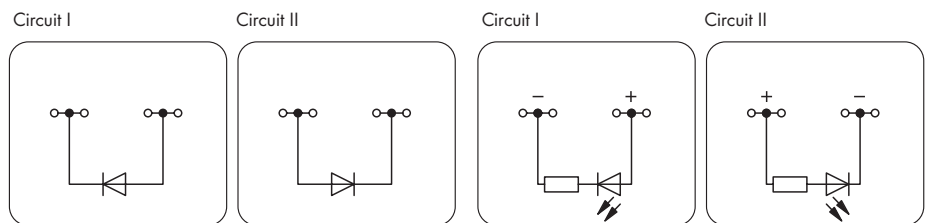
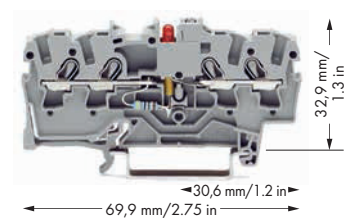
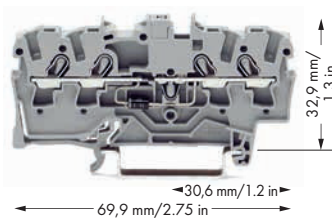

Item No.	Pack. Unit	Item No.	Pack. Unit
Through terminal blocks with same profile, see page 12		4-conductor diode terminal block with 1N4007 diode, gray	
○ Circuit I	2001-1411/1000-411 100	○ Circuit I	2001-1421/1000-413 100
○ Circuit II	2001-1411/1000-410 100	○ Circuit II	2001-1421/1000-434 100

Circuit Configuration Examples

Diode Terminal Blocks and LED Terminal Blocks

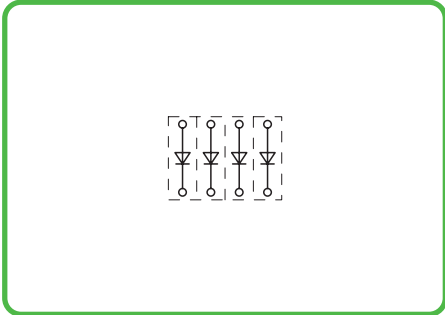

Open diode gates can be created using the following terminal blocks:
2001-1211/1000-410 or
2001-1211/1000-411

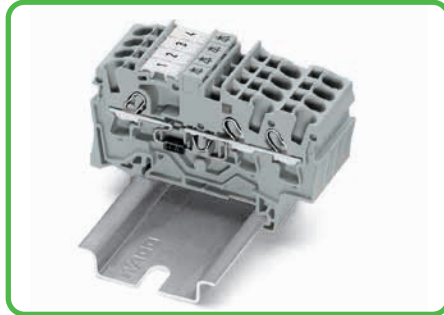

These diode terminal blocks have been specially developed for custom diode circuits, such as lamp test and collective fault signal circuits.
 Using LED terminal blocks, monitoring units can be designed, e.g., for control and operating circuits.

- ❶ Conductor sizes: 0.25 mm² - 2.5 mm² "s + f-st";
 Push-in conductor sizes: 0.5 mm² - 2.5 mm² "s"
 and 0.75 mm² - 1.5 mm²
 "insulated ferrules, 12 mm"
- ❷ Strip length, see packaging or instructions.

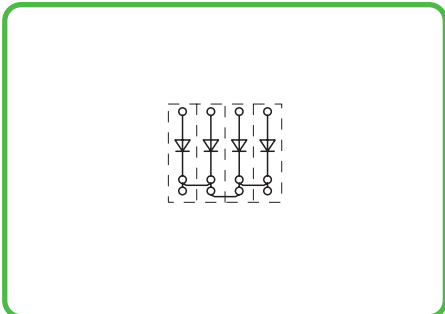

Polarized diode gates with common cathode can be created using the following terminal blocks:
2001-1311/1000-410 or
2001-1311/1000-411

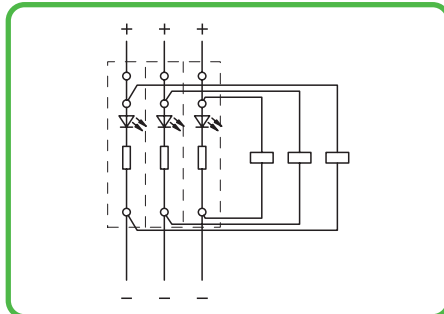

Circuit-related voltage indications can be created using the following terminal blocks:
2001-1321/1000-434 or
2001-1321/1000-413

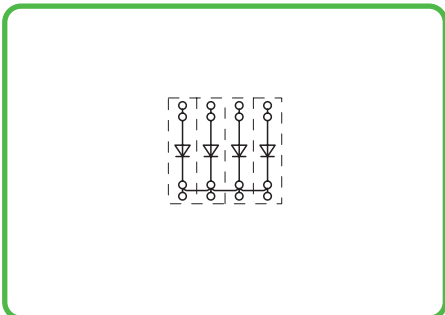

Polarized diode gates with common cathode can be created using the following terminal blocks:
2001-1411/1000-410 or
2001-1411/1000-411

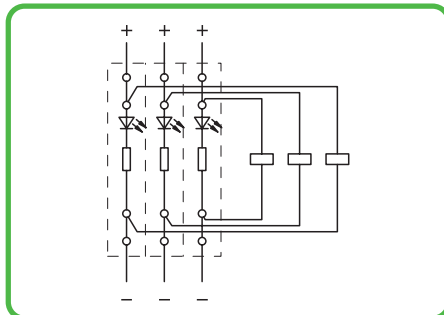

Circuit-related voltage indications can be created using the following terminal blocks:
2001-1421/1000-434 or
2001-1421/1000-413

2001 Series Accessories

Insulation stop,

	5 pcs/strip, 0.25 - 0.5 mm ² light gray	2001-171	200 (8x25)
--	--	-----------------	------------

Push-in type jumper bar, insulated,

	I _N 18 A, light gray		
	2-way	2001-402	200 (8x25)
	3-way	2001-403	200 (8x25)
	4-way	2001-404	200 (8x25)
	5-way	2001-405	100 (4x25)
	6-way	2001-406	100 (4x25)
	7-way	2001-407	100 (4x25)
	8-way	2001-408	100 (4x25)
	9-way	2001-409	100 (4x25)
	10-way	2001-410	100 (4x25)

Push-in type jumper bar, insulated,

	I _N 18 A, light gray		
	from 1 to 3	2001-433	200 (8x25)
	from 1 to 4	2001-434	200 (8x25)
	from 1 to 5	2001-435	100 (4x25)
	from 1 to 6	2001-436	100 (4x25)
	from 1 to 7	2001-437	100 (4x25)
	from 1 to 8	2001-438	100 (4x25)
	from 1 to 9	2001-439	100 (4x25)
	from 1 to 10	2001-440	100 (4x25)

<p>0.25 - 2.5 (4) mm² ① AWG 22 - 12 U_N 250 V, U_{RM} 1000 V 1N4007 - 0.5 A continuous current Terminal block width 5.2 mm / 0.205 in 10 - 12 mm / 0.43 in ②</p>	<p>0.25 - 2.5 (4) mm² ① AWG 22 - 12 U_N 250 V, U_{RM} 1000 V 1N4007 - 0.5 A continuous current Terminal block width 5.2 mm / 0.205 in 10 - 12 mm / 0.43 in ②</p>	<p>0.25 - 2.5 (4) mm² ① AWG 22 - 12 24 VDC I_F 0.025 A max. Terminal block width 5.2 mm / 0.205 in 10 - 12 mm / 0.43 in ②</p>
---	---	--

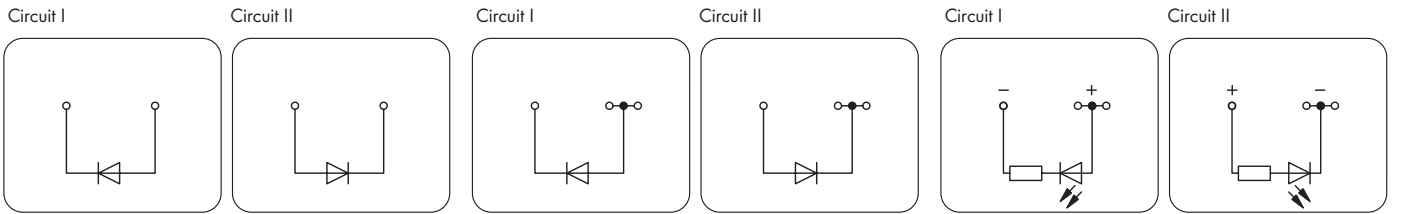
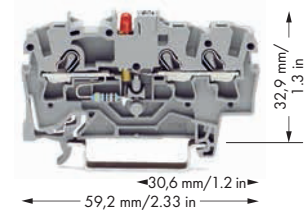
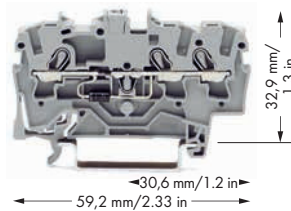
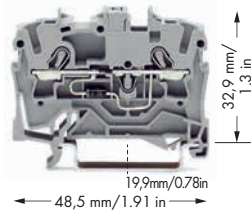

Item No.	Pack. Unit	Item No.	Pack. Unit	Item No.	Pack. Unit
2-conductor diode terminal block with 1N4007 diode, gray		3-conductor diode terminal block with 1N4007 diode, gray		3-conductor LED terminal block with red LED, 24 VDC, gray Notice: This LED terminal block cannot be commoned with push-in type jumper bars!	
○ Circuit I	2002-1211/1000-411 100	○ Circuit I	2002-1311/1000-411 100	○ Circuit I	2002-1321/1000-413 100
○ Circuit II	2002-1211/1000-410 100	○ Circuit II	2002-1311/1000-410 100	○ Circuit II	2002-1321/1000-434 100

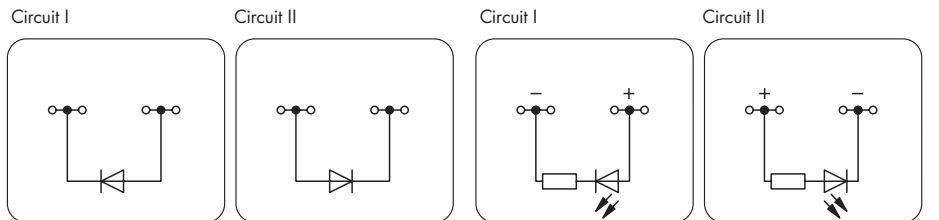
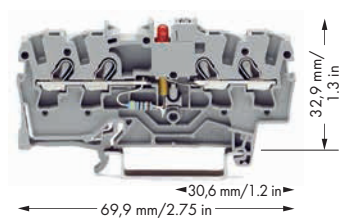
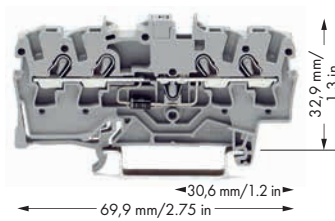

Item No.	Pack. Unit	Item No.	Pack. Unit
Through terminal blocks with same profile, see page 14		4-conductor diode terminal block with 1N4007 diode, gray	
○ Circuit I	2002-1411/1000-411 100	○ Circuit I	2002-1421/1000-413 100
○ Circuit II	2002-1411/1000-410 100	○ Circuit II	2002-1421/1000-434 100

Circuit Configuration Examples

Diode Terminal Blocks and LED Terminal Blocks

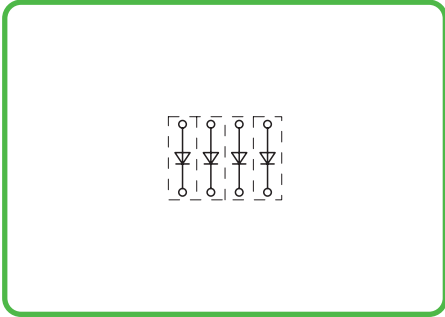

Open diode gates can be created using the following terminal blocks:
 2002-1211/1000-410 or
 2002-1211/1000-411

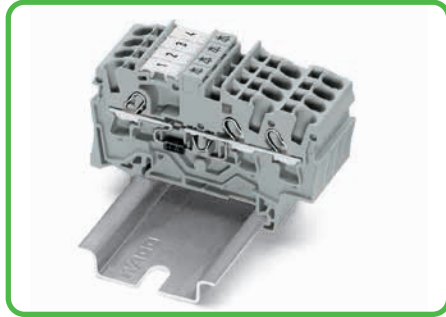

These diode terminal blocks have been specially developed for custom diode circuits, such as lamp test and collective fault signal circuits.

- ① Conductor sizes: 0.25 mm² - 4 mm² "s + f-st";
 Push-in conductor sizes: 0.75 mm² - 4 mm² "s"
 and 0.75 mm² - 2.5 mm²
 "insulated ferrules, 12 mm"
- ② Strip length, see packaging or instructions.

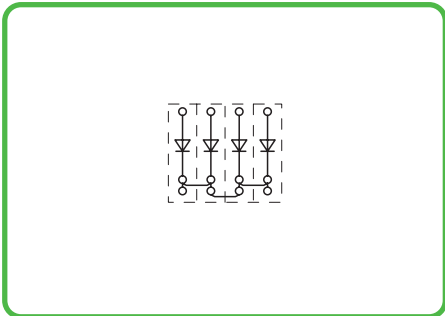

Polarized diode gates with common cathode can be created using the following terminal blocks:
 2002-1311/1000-410 or
 2002-1311/1000-411

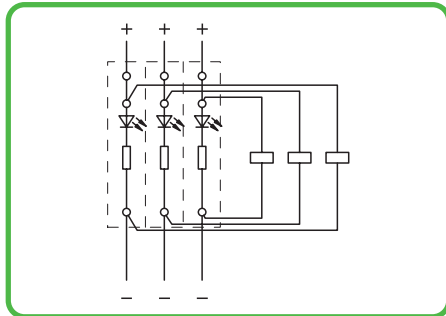

Circuit-related voltage indications can be created using the following terminal blocks:
 2002-1321/1000-434 or
 2002-1321/1000-413

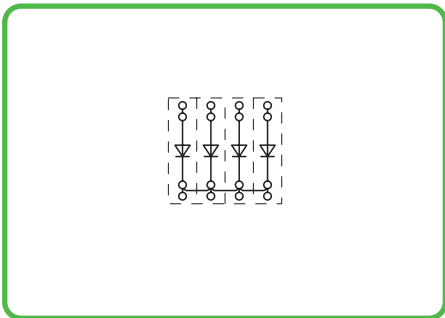

Polarized diode gates with common cathode can be created using the following terminal blocks:
 2002-1411/1000-410 or
 2002-1411/1000-411

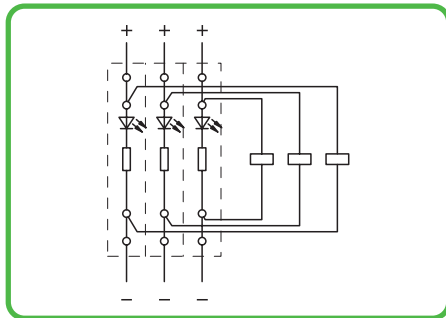

Circuit-related voltage indications can be created using the following terminal blocks:
 2002-1421/1000-434 or
 2002-1421/1000-413

2002 Series Accessories

Insulation stop,			
	5 pcs/strip, 0.25 - 0.5 mm ² light gray	2002-171	200 (8x25)

Insulation stop,			
	5 pcs/strip, 0.75 - 1 mm ² dark gray	2002-172	200 (8x25)



Push-in type jumper bar, insulated,			
	I _N 25 A, light gray		
	2-way	2002-402	200 (8x25)
	3-way	2002-403	200 (8x25)
	4-way	2002-404	200 (8x25)
	5-way	2002-405	100 (4x25)
	6-way	2002-406	100 (4x25)
	7-way	2002-407	100 (4x25)
	8-way	2002-408	100 (4x25)
	9-way	2002-409	100 (4x25)
	10-way	2002-410	100 (4x25)

Push-in type jumper bar, insulated,			
	I _N 25 A, light gray		
	from 1 to 3	2002-433	200 (8x25)
	from 1 to 4	2002-434	200 (8x25)
	from 1 to 5	2002-435	100 (4x25)
	from 1 to 6	2002-436	100 (4x25)
	from 1 to 7	2002-437	100 (4x25)
	from 1 to 8	2002-438	100 (4x25)
	from 1 to 9	2002-439	100 (4x25)
	from 1 to 10	2002-440	100 (4x25)

TOPJOB® S

Diode Terminal Blocks 4 (6) mm²

2004 Series

<p>0.5 - 4 (6) mm² ① AWG 20 - 10 U_N 250 V, U_{RM} 1000 V 1N5408 - 1.5 A continuous current Terminal block width 6.2 mm / 0.244 in  11 - 13 mm / 0.47 in ②</p>	<p>0.5 - 4 (6) mm² ① AWG 20 - 10 U_N 250 V, U_{RM} 1000 V 1N5408 - 1.5 A continuous current Terminal block width 6.2 mm / 0.244 in  11 - 13 mm / 0.47 in ②</p>
---	--

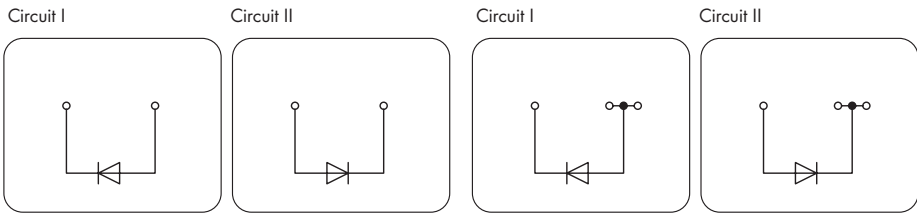
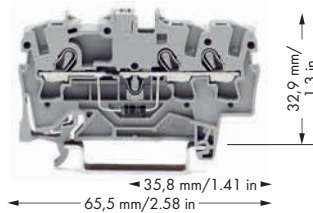
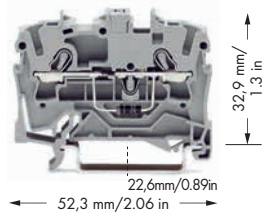

Item No.	Pack. Unit	Item No.	Pack. Unit
2-conductor diode terminal block with 1N5408 diode, gray		3-conductor diode terminal block with 1N5408 diode, gray	
● Circuit I	2004-1211/1000-401 50	● Circuit I	2004-1311/1000-401 50
● Circuit II	2004-1211/1000-400 50	● Circuit II	2004-1311/1000-400 50

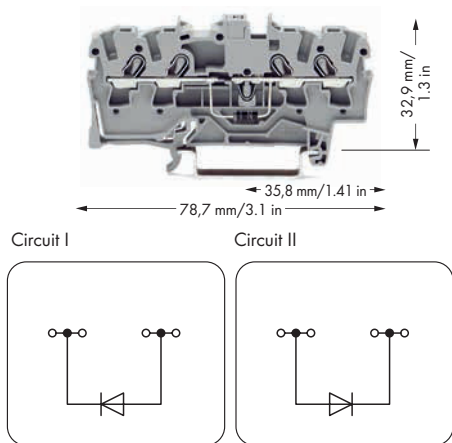

Item No.	Pack. Unit
Through terminal blocks with same profile, see page 18	
4-conductor diode terminal block with 1N5408 diode, gray	
● Circuit I	2004-1411/1000-401 50
● Circuit II	2004-1411/1000-400 50

Circuit Configuration Examples Diode Terminal Blocks

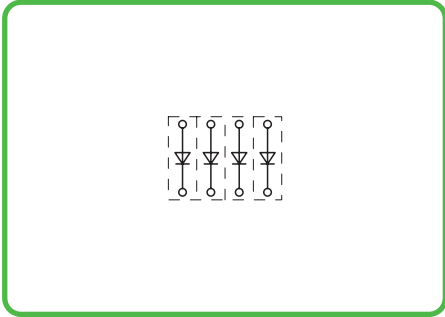

Open diode gates can be created using the following terminal blocks:
2004-1211/1000-400 or
2004-1211/1000-401

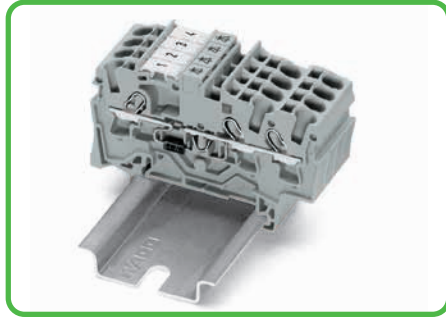

These diode terminal blocks have been specially developed for custom diode circuits, such as lamp test and collective fault signal circuits.

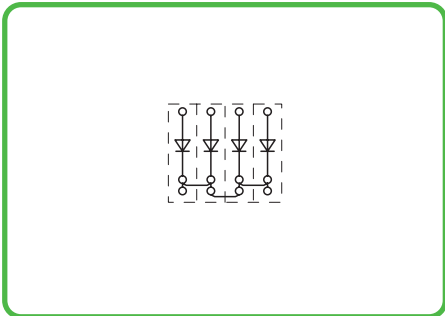



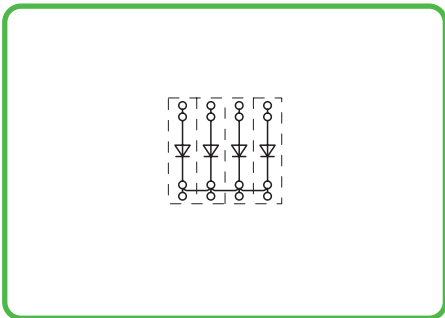



Polarized diode gates with common cathode can be created using the following terminal blocks:
2004-1311/1000-400 or
2004-1311/1000-401



Polarized diode gates with common cathode can be created using the following terminal blocks:
2004-1411/1000-400 or
2004-1411/1000-401

- ① Conductor sizes: 0.5 mm² - 6 mm² "s + fst";
Push-in conductor sizes: 1 mm² - 6 mm² "s"
and 0.75 mm² - 2.5 mm²
"insulated ferrule, 1.2 mm"
- ② Strip length, see packaging or instructions.

2004 Series Accessories

Insulation stop,			
	5 pcs/strip, 0.25 - 0.5 mm ² light gray	2004-171	200 (8x25)
Insulation stop,			
	5 pcs/strip, 0.75 - 1 mm ² dark gray	2004-172	200 (8x25)
Push-in type jumper bar, insulated,			
	I _N 32 A, light gray		
	2-way	2004-402	200 (8x25)
	3-way	2004-403	200 (8x25)
	4-way	2004-404	100 (4x25)
	5-way	2004-405	100 (4x25)
	6-way	2004-406	100 (4x25)
	7-way	2004-407	100 (4x25)
	8-way	2004-408	100 (4x25)
	9-way	2004-409	100 (4x25)
	10-way	2004-410	100 (4x25)
Push-in type jumper bar, insulated,			
	I _N 32 A, light gray		
	from 1 to 3	2004-433	200 (8x25)
	from 1 to 4	2004-434	200 (8x25)
	from 1 to 5	2004-435	100 (4x25)
	from 1 to 6	2004-436	100 (4x25)
	from 1 to 7	2004-437	100 (4x25)
	from 1 to 8	2004-438	100 (4x25)
	from 1 to 9	2004-439	100 (4x25)
	from 1 to 10	2004-440	100 (4x25)
Wire commoning chain, 50 connections,			
	insulated, I _N 8 A black	210-103	1
Wire commoning chain, 50 connections,			
	insulated, I _N 8 A blue	210-123	1

TOPJOB® S

Double-Deck Diode Terminal Blocks and LED Terminal Blocks 2.5 (4) mm²

2002 Series

<p>0.25 - 2.5 (4) mm² ① AWG 22 - 12 U_N 250 V, U_{RM} 1000 V 1N4007 - 0.5 A continuous current Terminal block width 5.2 mm / 0.205 in ☐ 10 - 12 mm / 0.43 in ②</p>	<p>0.25 - 2.5 (4) mm² ① AWG 22 - 12 U_N 250 V, U_{RM} 1000 V 1N4007 - 0.5 A continuous current Terminal block width 5.2 mm / 0.205 in ☐ 10 - 12 mm / 0.43 in ②</p>	<p>0.25 - 2.5 (4) mm² ① AWG 22 - 12 24 VDC I_F 0.025 A max. Terminal block width 5.2 mm / 0.205 in ☐ 10 - 12 mm / 0.43 in ②</p>
---	---	--

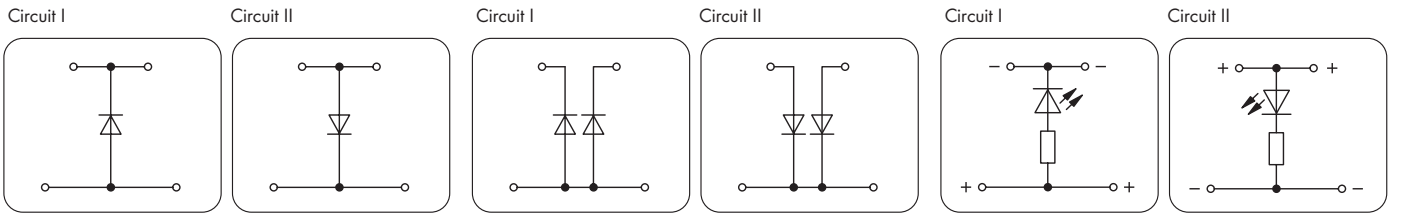
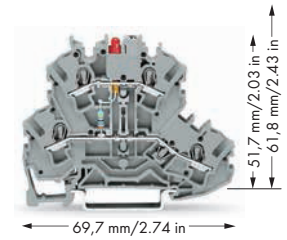
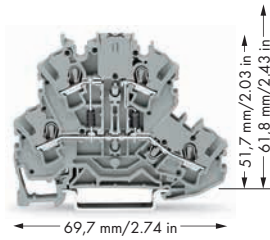
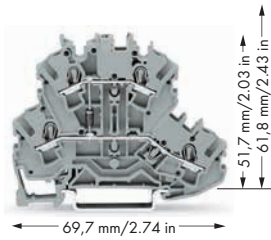

Item No.	Pack. Unit	Item No.	Pack. Unit	Item No.	Pack. Unit
Double-deck diode terminal block with 1N4007 diode, gray		Double-deck diode terminal block with 2 diodes 1N4007, gray		Double-deck LED terminal block with red LED, 24 VDC, gray	
● Circuit I	2002-2211/1000-410 50	● Circuit I	2002-2213/1000-487 50	● Circuit I	2002-2221/1000-434 50
● Circuit II	2002-2211/1000-411 50	● Circuit II	2002-2213/1000-488 50	● Circuit II	2002-2221/1000-413 50

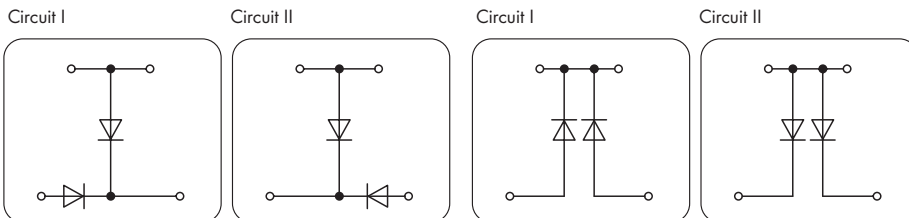
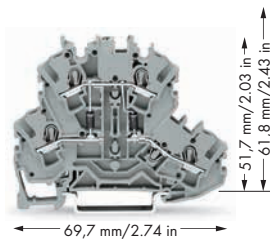
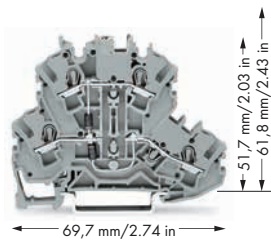

Item No.	Pack. Unit	Item No.	Pack. Unit	
Double-deck diode terminal block with 2 diodes 1N4007, gray		Double-deck diode terminal block with 2 diodes 1N4007, gray		Through terminal blocks with same profile, see page 28
● Circuit I	2002-2214/1000-492 50	● Circuit I	2002-2214/1000-489 50	
● Circuit II	2002-2214/1000-491 50	● Circuit II	2002-2214/1000-490 50	

Circuit Configuration Examples

Double-Deck Diode and LED Terminal Blocks

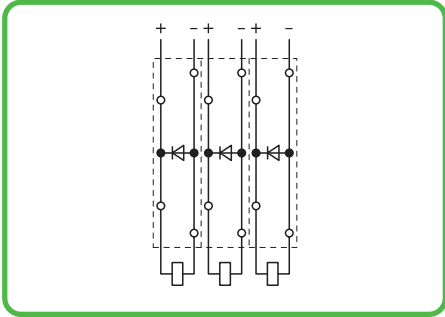

Recovery diodes can be created using the following terminal blocks:
2002-2211/1000-410 or
2002-2211/1000-411

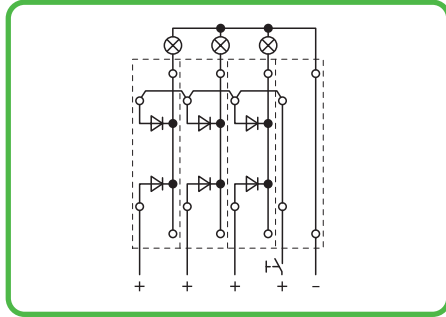

Lamp test circuits can be created using the following terminal blocks:
2002-2213/1000-487 or
2002-2213/1000-488

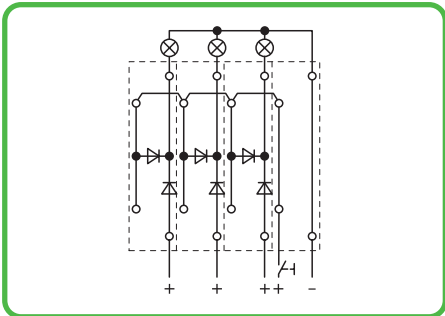

Lamp test circuits can be created using the following terminal blocks:
2002-2214/1000-492 or
2002-2214/1000-491

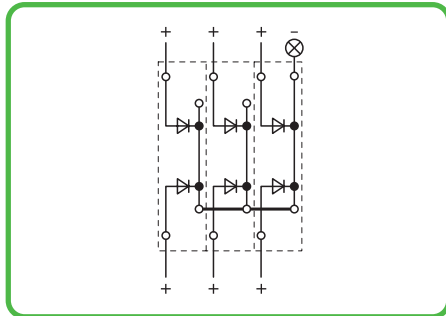

Collective fault signals can be created using the following terminal blocks:
2002-2214/1000-489 or
2002-2214/1000-490

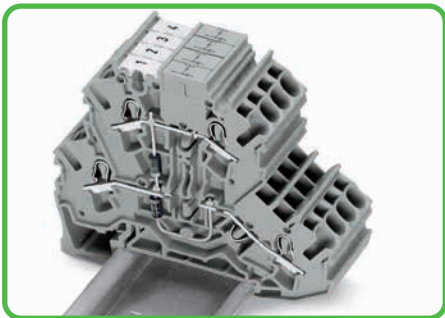



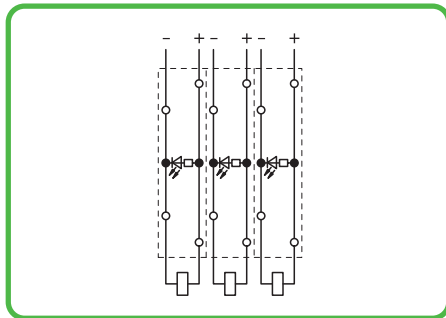



Double-deck diode terminal blocks have been specially developed for custom diode circuits, such as lamp test and collective fault signal circuits. Using LED terminal blocks, monitoring units can be designed, e.g., for control and operating circuits. The terminal blocks provide high-density wiring, while maintaining a width of only 5 mm. Push-in type jumper bars provide additional options for custom circuit design.



Circuit-related voltage indications can be created using the following terminal blocks:
2002-2221/1000-434 or
2002-2221/1000-413

- ① Conductor sizes: 0.25 mm² - 4 mm² "s + f-st"; Push-in conductor sizes: 0.75 mm² - 4 mm² "s" and 0.75 mm² - 2.5 mm² "insulated ferrules, 12 mm"
- ② Strip length, see packaging or instructions.

2002 Series Accessories

End and intermediate plate, 0.8 mm thick			
	orange	2002-2292	100 (4x25)
	gray	2002-2291	100 (4x25)
Double-deck marker carrier,			
	pivoting		
	gray	2002-121	50 (2x25)
Insulation stop,			
	5 pcs/strip,		
	0.25 - 0.5 mm ²		
	light gray	2002-171	200 (8x25)
Insulation stop,			
	5 pcs/strip,		
	0.75 - 1 mm ²		
	dark gray	2002-172	200 (8x25)
Push-in type jumper bar, insulated,			
	I _N 25 A,		
	light gray		
	2-way	2002-402	200 (8x25)
	3-way	2002-403	200 (8x25)
	4-way	2002-404	200 (8x25)
	5-way	2002-405	100 (4x25)
	6-way	2002-406	100 (4x25)
	7-way	2002-407	100 (4x25)
	8-way	2002-408	100 (4x25)
	9-way	2002-409	100 (4x25)
	10-way	2002-410	100 (4x25)
Push-in type jumper bar, insulated,			
	I _N 25 A,		
	light gray		
	from 1 to 3	2002-433	200 (8x25)
	from 1 to 4	2002-434	200 (8x25)
	from 1 to 5	2002-435	100 (4x25)
	from 1 to 6	2002-436	100 (4x25)
	from 1 to 7	2002-437	100 (4x25)
	from 1 to 8	2002-438	100 (4x25)
	from 1 to 9	2002-439	100 (4x25)
	from 1 to 10	2002-440	100 (4x25)

TOPJOB® S Triple-Deck Diode Terminal Blocks and LED Terminal Blocks 2.5 (4) mm² 2002 Series

<p>0.25 - 2.5 (4) mm² ① AWG 22 - 12 U_N 250 V, U_{RM} 1000 V 1N4007 - 0.5 A continuous current Terminal block width 5.2 mm / 0.205 in 10 - 12 mm / 0.43 in ②</p>	<p>0.25 - 2.5 (4) mm² ① AWG 22 - 12 U_N 250 V, U_{RM} 1000 V 1N4007 - 0.5 A continuous current Terminal block width 5.2 mm / 0.205 in 10 - 12 mm / 0.43 in ②</p>	<p>0.25 - 2.5 (4) mm² ① AWG 22 - 12 24 VDC I_F 0.025 A max. Terminal block width 5.2 mm / 0.205 in 10 - 12 mm / 0.43 in ②</p>
--	--	---

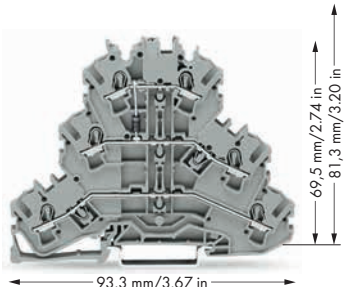

93,3 mm / 3.67 in

69,5 mm / 2.74 in
81,3 mm / 3.20 in

Circuit I Circuit II

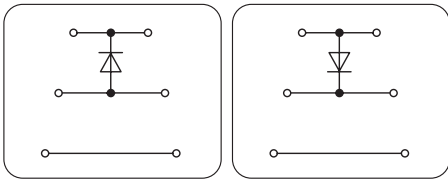

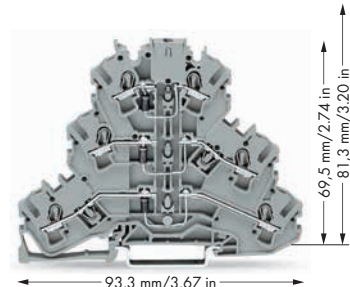

93,3 mm / 3.67 in

69,5 mm / 2.74 in
81,3 mm / 3.20 in

Circuit I Circuit II

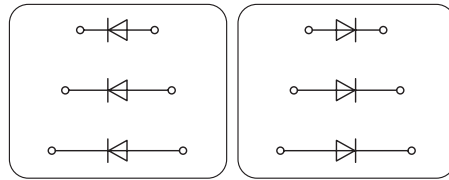

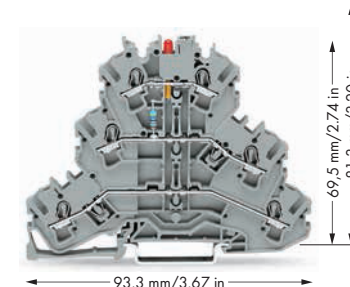

93,3 mm / 3.67 in

69,5 mm / 2.74 in
81,3 mm / 3.20 in

Circuit I Circuit II

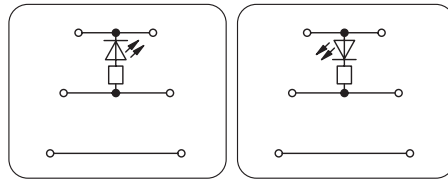

Item No.	Pack. Unit	Item No.	Pack. Unit	Item No.	Pack. Unit
Triple-deck diode terminal block with 1N4007 diode, gray		Triple-deck diode terminal block with 3 diodes 1N4007, gray		Triple-deck LED terminal block with red LED, 24 VDC, gray	
● Circuit I	2002-3211/1000-410 50	● Circuit I	2002-3212/1000-673 50	● Circuit I	2002-3221/1000-434 50
● Circuit II	2002-3211/1000-411 50	● Circuit II	2002-3212/1000-674 50	● Circuit II	2002-3221/1000-413 50

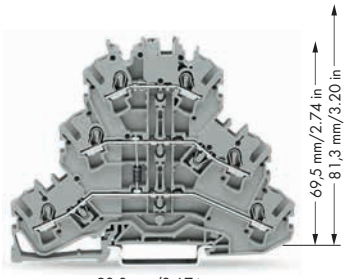

93,3 mm / 3.67 in

69,5 mm / 2.74 in
81,3 mm / 3.20 in

Circuit I Circuit II

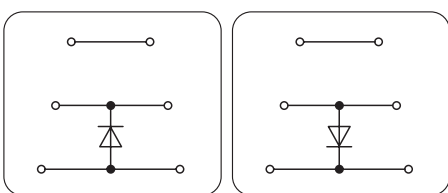

Item No.	Pack. Unit	Item No.	Pack. Unit
Triple-deck diode terminal block with 1N4007 diode, gray		Through terminal blocks with same profile, see page 38	
● Circuit I	2002-3211/1000-675 50		
● Circuit II	2002-3211/1000-676 50		

Circuit Configuration Example Triple-Deck Diode Terminal Blocks

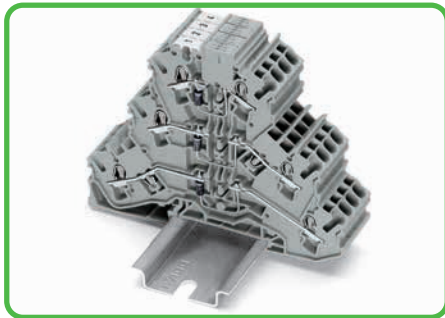

Triple-deck diode terminal blocks have been specially developed for custom diode circuits, such as lamp test and collective fault signal circuits. Using LED terminal blocks, monitoring units can be designed, e.g., for control and operating circuits. The terminal blocks provide high-density wiring, while maintaining a width of only 5.2 mm. Push-in type jumper bars provide additional options for custom circuit design.

- ❶ Conductor sizes: 0.25 mm² – 4 mm² "s + f-st"; Push-in conductor sizes: 0.75 mm² – 4 mm² "s" and 0.75 mm² – 2.5 mm² "insulated ferrules, 12 mm"
- ❷ Strip length, see packaging or instructions.

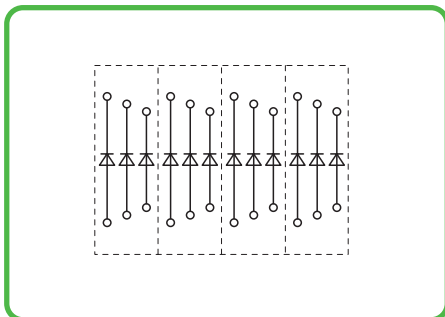



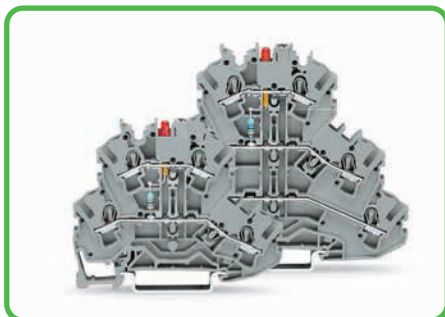















Open diode gates can be created, which can be connected individually using the following terminal blocks:
2002-3212/1000-673 or 2002-3212/1000-674
 Using push-in type jumper bars, individual levels can be turned into polarized diode gates.



Double-deck and triple-deck LED terminal blocks

2002 Series Accessories

Appropriate marking systems: WMB/WMB Inline/Marking strips
 (see Section 13)

End and intermediate plate, 0.8 mm thick  orange 2002-3292 100 (4x25) gray 2002-3291 100 (4x25)	End plate,  for modular TOPJOB®S connectors, 1.5 mm thick gray 2002-541 100 (4x25)
Triple-deck marker carrier,  pivoting gray 2002-131 50 (2x25)	Test plug,  with 500 mm cable, 2 mm Ø red 210-136 50
Insulation stop,  5 pcs/strip, 0.25 - 0.5 mm ² light gray 2002-171 200 (8x25)	Test plug adapter,  for 4 mm Ø test plug gray 2009-174 100 (4x25)
Insulation stop,  5 pcs/strip, 0.75 - 1 mm ² dark gray 2002-172 200 (8x25)	Testing tap,  for max. 2.5 mm ² gray 2009-182 100 (4x25)
Push-in type jumper bar, insulated,  I _N 25 A, light gray 2-way 2002-402 200 (8x25) 3-way 2002-403 200 (8x25) 4-way 2002-404 200 (8x25) 5-way 2002-405 100 (4x25) 6-way 2002-406 100 (4x25) 7-way 2002-407 100 (4x25) 8-way 2002-408 100 (4x25) 9-way 2002-409 100 (4x25) 10-way 2002-410 100 (4x25)	Banana plug,  for socket 4 mm Ø, color mixed 215-111 50
	WMB Multi marking system,  10 strips with 10 markers per card, stretchable 5 - 5.2 mm plain 793-5501 5
	WMB Inline, plain,  stretchable 5 - 5.2 mm, 1,500 WMB markers, 5 mm, on roll white 2009-115 1
Push-in type jumper bar, insulated,  I _N 25 A, light gray from 1 to 3 2002-433 200 (8x25) from 1 to 4 2002-434 200 (8x25) from 1 to 5 2002-435 100 (4x25) from 1 to 6 2002-436 100 (4x25) from 1 to 7 2002-437 100 (4x25) from 1 to 8 2002-438 100 (4x25) from 1 to 9 2002-439 100 (4x25) from 1 to 10 2002-440 100 (4x25)	Marking strip, plain,  11 mm wide, 50 m roll white 2009-110 1
	TOPJOB®S group marker carrier,  snap-on type for jumper slot, 5 mm wide gray 2009-191 50 (2x25)
	Screwless end stop,  for DIN 35 rail, 6 mm wide gray 249-116 100 (4x25)
Modular TOPJOB®S connector,  can be snapped together, for jumper contact slot gray 2002-511 100 (4x25)	Screwless end stop,  for DIN 35 rail, 10 mm wide gray 249-117 50 (2x25)
Spacer module, can be snapped together,  e.g., for bridging commoned terminal blocks gray 2002-549 100 (4x25)	

Diode module
with 1N4007 diode
U_N 250 V, U_{RM} 1000 V

I_N 1 A
Plug width 5.2 mm / 0.205 in

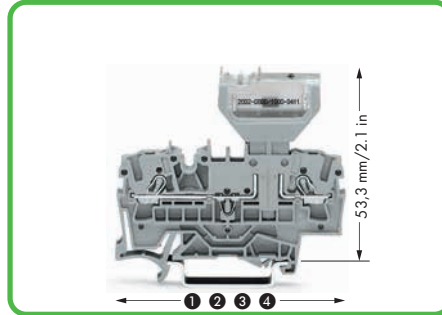

These diode have been designed for use in lamp test circuits or collective fault indicating systems, and offer the following advantages:

- Separation into functional and wiring level
- Polarized direction of switching
- Quick and easy exchange of modules
- High density with only 5.2 mm width of terminal block and module

- 1 Length of 2002-1661: 66.5 mm / 2.62 in
2-conductor carrier terminal block
- 2 Length of 2002-1761: 76.8 mm / 3.02 in
3-conductor carrier terminal block
- 3 Length of 2002-1861: 87.5 mm / 3.45 in
4-conductor carrier terminal block
- 4 Length of 2002-1961: 72.9 mm / 2.87 in
2-conductor carrier terminal block with additional jumper position
- 5 See application notes for:
Colored push-in type jumper bars, page 101
Staggered jumper, page 104
Push-in type wire jumper, page 102

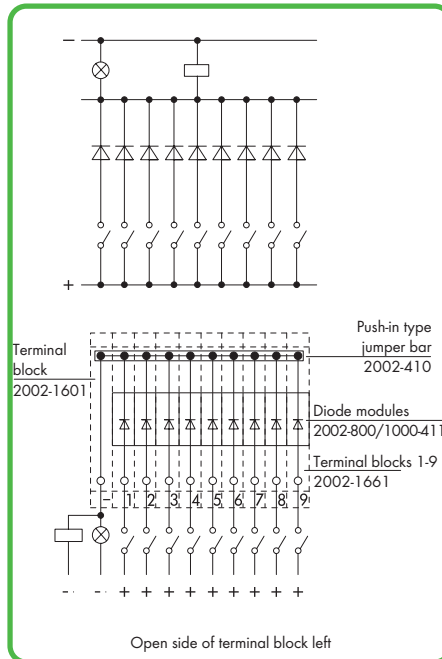
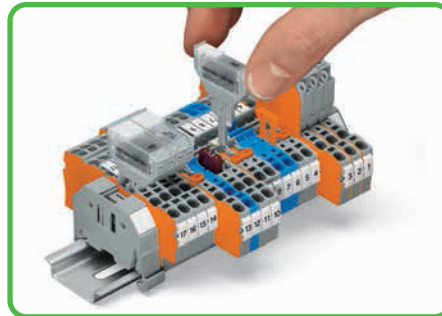
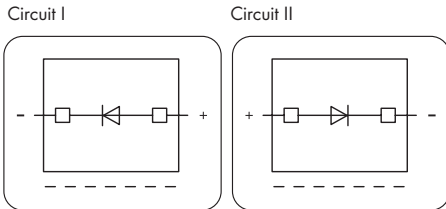

Diode gate for collective fault indication

Item No.	Pack. Unit
Diode module, with 1N4007 diode, max. operating temperature: 85 °C, gray, 5.2 mm wide	
○ Circuit I 2002-800/1000-411	100
○ Circuit II 2002-800/1000-410	100
Carrier Term. Blocks and Accessories Appropriate marking system: WMB/Marking strips	
2-conductor carrier terminal block, 1 0.25 - 2.5 (4) mm ² / AWG 22 - 12 Terminal block width 5.2 mm / 0.205 in gray 2002-1661 50	
End and intermediate plate, 1 mm thick orange 2002-1692 100 (4x25) gray 2002-1691 100 (4x25)	
3-conductor carrier terminal block, 2 0.25 - 2.5 (4) mm ² / AWG 22 - 12 Terminal block width 5.2 mm / 0.205 in gray 2002-1761 50	
End and intermediate plate, 1 mm thick orange 2002-1792 100 (4x25) gray 2002-1791 100 (4x25)	
4-conductor carrier terminal block, 3 0.25 - 2.5 (4) mm ² / AWG 22 - 12 Terminal block width 5.2 mm / 0.205 in gray 2002-1861 50	
End and intermediate plate, 1 mm thick orange 2002-1892 100 (4x25) gray 2002-1891 100 (4x25)	
2-conductor carrier terminal block, 4 0.25 - 2.5 (4) mm ² / AWG 22 - 12 Terminal block width 5.2 mm / 0.205 in gray 2002-1961 50	
End and intermediate plate, 1 mm thick orange 2002-1992 100 (4x25) gray 2002-1991 100 (4x25)	

Accessories

Push-in type wire jumper, 5 insulated, I _N 18 A, wire size 1.5 mm ²			
L = 60 mm	2009-412	100	(10x10)
L = 110 mm	2009-414	100	(10x10)
L = 250 mm	2009-416	100	(10x10)

Push-in type jumper bar, insulated, 5 I _N 25 A, light gray			
2-way	2002-402	200	(8x25)
3-way	2002-403	200	(8x25)
4-way	2002-404	200	(8x25)
5-way	2002-405	100	(4x25)
6-way	2002-406	100	(4x25)
7-way	2002-407	100	(4x25)
8-way	2002-408	100	(4x25)
9-way	2002-409	100	(4x25)
10-way	2002-410	100	(4x25)

Push-in type jumper bar, insulated, I _N 25 A, light gray			
from 1 to 3	2002-433	200	(8x25)
from 1 to 4	2002-434	200	(8x25)
from 1 to 5	2002-435	100	(4x25)
from 1 to 6	2002-436	100	(4x25)
from 1 to 7	2002-437	100	(4x25)
from 1 to 8	2002-438	100	(4x25)
from 1 to 9	2002-439	100	(4x25)
from 1 to 10	2002-440	100	(4x25)

Staggered jumper, 5 insulated, I _N 25 A, light gray			
2-way	2002-472	100	(4x25)
3-way	2002-473	100	(4x25)
4-way	2002-474	100	(4x25)
5-way	2002-475	50	(2x25)
6-way	2002-476	50	(2x25)
7-way	2002-477	50	(2x25)
8-way	2002-478	50	(2x25)
9-way	2002-479	50	(2x25)
10-way	2002-480	50	(2x25)
11-way	2002-481	50	(2x25)
12-way	2002-482	50	(2x25)

TOPJOB® S

Pluggable Diode Modules and Empty Component Plug Housing on Through Terminal Blocks 2.5 (4) mm², 2002 Series

Diode module
with 1N4007 diode as free-wheeling diode
U_N 250 V, U_{RM} 1000 V
I_N 1 A
Plug width 10.4 mm / 0.409 in

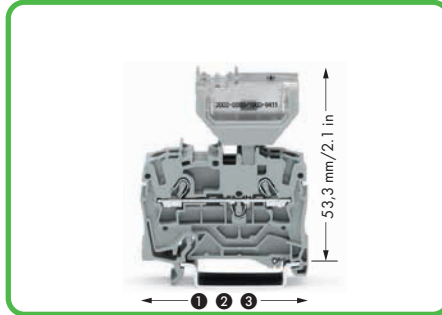

Similar to a push-in jumper, these diode modules are simply pushed into the contact slots of the current bars for two adjacent through terminal blocks.

This offers the following advantages:

- These modules are suitable for **all 2001 to 2006** Series through terminal blocks equipped with jumper slots (please note the module's width).
- Easily retrofit terminal blocks with diode modules.

- ① Length of 2002-1201: 48.5 mm / 1.91 in 2-conductor carrier terminal block
- ② Length of 2002-1301: 59.5 mm / 2.34 in 3-conductor carrier terminal block
- ③ Length of 2002-1401: 70 mm / 2.76 in 4-conductor carrier terminal block
- ④ See application notes for:
Colored push-in type jumper bars, page 101
Staggered jumper, page 104
Push-in type wire jumper, page 102

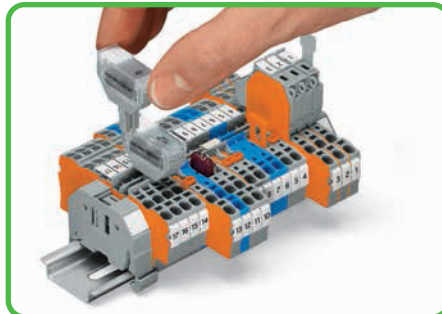
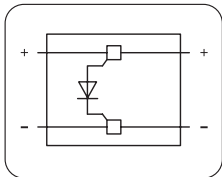

Plugging a diode module into a through terminal block.

Additional advantages:

- Separation into functional and wiring level
- Modules can be replaced quickly by other types of modules
- Solder-free assembly of diodes, resistors, etc.



Opening the cover via operating tool (blade width 2.5 mm).

Accessories

Insulation stop,			
	5 pcs/strip, 0.75 - 1 mm ² dark gray	2002-172	200 (8x25)

Protective warning marker,			
with high-voltage symbol, black, for 5 terminal blocks			
	yellow	2002-115	100 (4x25)

Push-in type wire jumper,			
④ insulated, I _N 18 A,			
	wire size 1.5 mm ² L = 60 mm	2009-412	100 (10x10)
	L = 110 mm	2009-414	100 (10x10)
	L = 250 mm	2009-416	100 (10x10)

Push-in type jumper bar, insulated,			
④ I _N 25 A, light gray			
	2-way	2002-402	200 (8x25)
	3-way	2002-403	200 (8x25)
	4-way	2002-404	200 (8x25)
	5-way	2002-405	100 (4x25)
	6-way	2002-406	100 (4x25)
	7-way	2002-407	100 (4x25)
	8-way	2002-408	100 (4x25)
	9-way	2002-409	100 (4x25)
	10-way	2002-410	100 (4x25)

Push-in type jumper bar, insulated,			
I _N 25 A, light gray			
	from 1 to 3	2002-433	200 (8x25)
	from 1 to 4	2002-434	200 (8x25)
	from 1 to 5	2002-435	100 (4x25)
	from 1 to 6	2002-436	100 (4x25)
	from 1 to 7	2002-437	100 (4x25)
	from 1 to 8	2002-438	100 (4x25)
	from 1 to 9	2002-439	100 (4x25)
	from 1 to 10	2002-440	100 (4x25)

Staggered jumper,			
④ insulated, I _N 25 A, light gray			
	2-way	2002-472	100 (4x25)
	3-way	2002-473	100 (4x25)
	4-way	2002-474	100 (4x25)
	5-way	2002-475	50 (2x25)

Item No.	Pack. Unit
Diode module,	
with 1N4007 diode as free-wheeling diode, max. operating temperature: 85 °C, 10.4 mm wide	
○ gray	2002-880/1000-411 50
Empty component plug housing type 4,	
2-pole, 10.4 mm wide	
○ gray	2002-880 50
Through Term. Blocks and Accessories	
Appropriate marking system: WMB/Marking strips	
2-conductor through terminal block,	
①	0.25 - 2.5 (4) mm ² / AWG 22 - 12 Terminal block width 5.2 mm / 0.205 in gray 2002-1201 100
End and intermediate plate, 0.8 mm thick	
	orange 2002-1292 100 (4x25) gray 2002-1291 100 (4x25)
3-conductor through terminal block,	
②	0.25 - 2.5 (4) mm ² / AWG 22 - 12 Terminal block width 5.2 mm / 0.205 in gray 2002-1301 100
End and intermediate plate, 0.8 mm thick	
	orange 2002-1392 100 (4x25) gray 2002-1391 100 (4x25)
4-conductor through terminal block,	
③	0.25 - 2.5 (4) mm ² / AWG 22 - 12 Terminal block width 5.2 mm / 0.205 in gray 2002-1401 100
End and intermediate plate, 0.8 mm thick	
	orange 2002-1492 100 (4x25) gray 2002-1491 100 (4x25)
Insulation stop,	
	5 pcs/strip, 0.25 - 0.5 mm ² light gray 2002-171 200 (8x25)

TOPJOB® S Pluggable LED Modules on Carrier Terminal Blocks 2.5 (4) mm² 2002 Series



LED module
 $I_N \leq 3 \text{ mA}$

Plug width 5.2 mm / 0.205 in

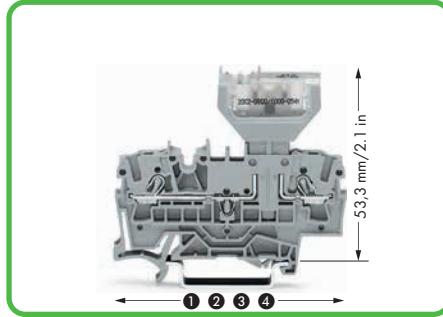

The monitoring of control and operating current circuits with LED modules on rail-mounted terminal blocks provides several advantages to the user:

- No additional cost for assembly and wiring
- Separation into functional and wiring level
- Modules can be replaced quickly and easily by other types of modules

- 1 Length of 2002-1661: 66.5 mm / 2.62 in
2-conductor carrier terminal block
- 2 Length of 2002-1761: 76.8 mm / 3.02 in
3-conductor carrier terminal block
- 3 Length of 2002-1861: 87.5 mm / 3.45 in
4-conductor carrier terminal block
- 4 Length of 2002-1961: 72.9 mm / 2.87 in
2-conductor carrier terminal block with additional jumper position
- 5 See application notes for:
Colored push-in type jumper bars, page 101
Staggered jumper, page 104
Push-in type wire jumper, page 102

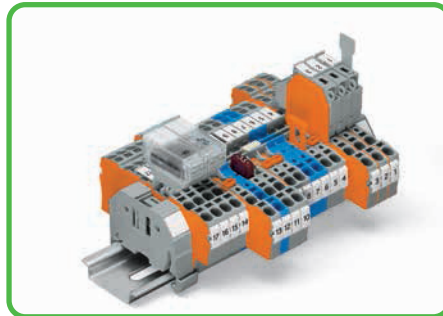
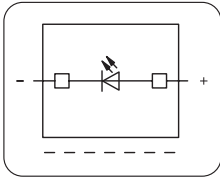

- Additional advantages:
- Polarized direction of switching
 - High density with only 5.2 mm width of terminal block and module

Item No.	Pack. Unit
LED module, with red LED, max. operating temperature: 85°C, 5.2 mm wide	
12 - 30 V 2002-800/1000-541	100
30 - 65 V 2002-800/1000-542	100
230 V 2002-800/1000-836	100
Carrier Term. Blocks and Accessories	
Appropriate marking system: WMB/Marking strips	
2-conductor carrier terminal block,	
1 0.25 - 2.5 (4) mm ² / AWG 22 - 12	
Terminal block width 5.2 mm / 0.205 in gray	2002-1661 50
End and intermediate plate, 1 mm thick	
orange	2002-1692 100 (4x25)
gray	2002-1691 100 (4x25)
32-conductor carrier terminal block,	
2 0.25 - 2.5 (4) mm ² / AWG 22 - 12	
Terminal block width 5.2 mm / 0.205 in gray	2002-1761 50
End and intermediate plate, 1 mm thick	
orange	2002-1792 100 (4x25)
gray	2002-1791 100 (4x25)
4-conductor carrier terminal block,	
3 0.25 - 2.5 (4) mm ² / AWG 22 - 12	
Terminal block width 5.2 mm / 0.205 in gray	2002-1861 50
End and intermediate plate, 1 mm thick	
orange	2002-1892 100 (4x25)
gray	2002-1891 100 (4x25)
2-conductor carrier terminal block,	
4 0.25 - 2.5 (4) mm ² / AWG 22 - 12	
Terminal block width 5.2 mm / 0.205 in gray	2002-1961 50
End and intermediate plate, 1 mm thick	
orange	2002-1992 100 (4x25)
gray	2002-1991 100 (4x25)

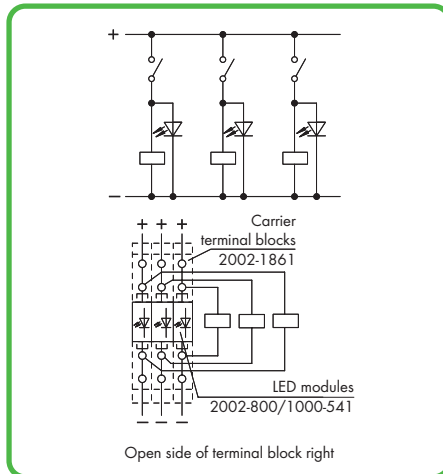

Accessories

Push-in type wire jumper,			
5	insulated, I_N 18 A, wire size 1.5 mm ²		
L = 60 mm	2009-412	100	(10x10)
L = 110 mm	2009-414	100	(10x10)
L = 250 mm	2009-416	100	(10x10)

Push-in type jumper bar, insulated,			
5	I_N 25 A, light gray		
2-way	2002-402	200	(8x25)
3-way	2002-403	200	(8x25)
4-way	2002-404	200	(8x25)
5-way	2002-405	100	(4x25)
6-way	2002-406	100	(4x25)
7-way	2002-407	100	(4x25)
8-way	2002-408	100	(4x25)
9-way	2002-409	100	(4x25)
10-way	2002-410	100	(4x25)

Push-in type jumper bar, insulated,			
	I_N 25 A, light gray		
from 1 to 3	2002-433	200	(8x25)
from 1 to 4	2002-434	200	(8x25)
from 1 to 5	2002-435	100	(4x25)
from 1 to 6	2002-436	100	(4x25)
from 1 to 7	2002-437	100	(4x25)
from 1 to 8	2002-438	100	(4x25)
from 1 to 9	2002-439	100	(4x25)
from 1 to 10	2002-440	100	(4x25)

Staggered jumper,			
5	insulated, I_N 25 A, light gray		
2-way	2002-472	100	(4x25)
3-way	2002-473	100	(4x25)
4-way	2002-474	100	(4x25)
5-way	2002-475	50	(2x25)
6-way	2002-476	50	(2x25)
7-way	2002-477	50	(2x25)
8-way	2002-478	50	(2x25)
9-way	2002-479	50	(2x25)
10-way	2002-480	50	(2x25)
11-way	2002-481	50	(2x25)
12-way	2002-482	50	(2x25)

TOPJOB® S Pluggable LED Modules on Through Terminal Blocks 2.5 (4) mm² 2002 Series

LED module
I_N ≤ 3 mA

Plug width 10.4 mm / 0.409 in

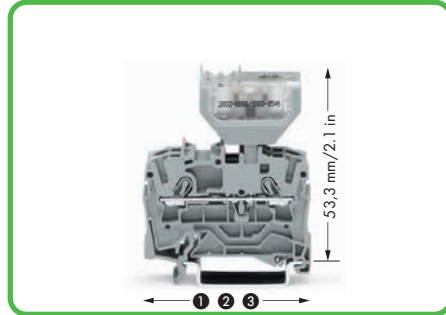

Similar to a push-in jumper, these LED modules are inserted into the current bar contact slots of two adjacent through terminal blocks.

These modules are suitable for all 2001 to 2006 Series through terminal blocks equipped with jumper slots (please note the module's width).

- Easily retrofit terminal blocks with diode modules.

- ① Length of 2002-1201: 48.5 mm / 1.91 in 2-conductor carrier terminal block
- ② Length of 2002-1301: 59.5 mm / 2.34 in 3-conductor carrier terminal block
- ③ Length of 2002-1401: 70 mm / 2.76 in 4-conductor carrier terminal block

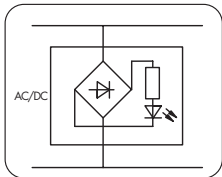

Marking using WMB Multi markers and marker strips.

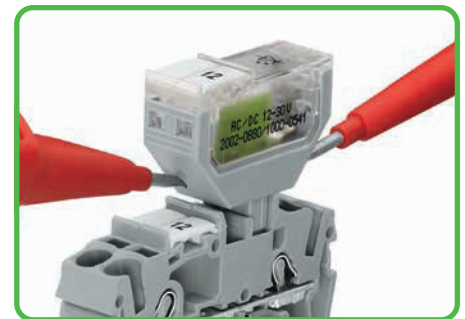

Testing

can also be performed using 2-pole test plugs.

Item No.	Pack. Unit
LED module, with red LED, max. operating temperature: 85° C, 10.4 mm wide	
● 12 - 30 V 2002-880/1000-541	50
● 30 - 65 V 2002-880/1000-542	50
● 230 V 2002-880/1000-836	50
Through Term. Blocks and Accessories	
Appropriate marking system: WMB/Marking strips	
2-conductor through terminal block,	
①	0.25 - 2.5 (4) mm ² / AWG 22 - 12 Terminal block width 5.2 mm / 0.205 in gray 2002-1201 100
End and intermediate plate, 0.8 mm thick	
	orange 2002-1292 100 (4x25)
	gray 2002-1291 100 (4x25)
3-conductor through terminal block,	
②	0.25 - 2.5 (4) mm ² / AWG 22 - 12 Terminal block width 5.2 mm / 0.205 in gray 2002-1301 100
End and intermediate plate, 0.8 mm thick	
	orange 2002-1392 100 (4x25)
	gray 2002-1391 100 (4x25)
4-conductor through terminal block,	
③	0.25 - 2.5 (4) mm ² / AWG 22 - 12 Terminal block width 5.2 mm / 0.205 in gray 2002-1401 100
End and intermediate plate, 0.8 mm thick	
	orange 2002-1492 100 (4x25)
	gray 2002-1491 100 (4x25)
Insulation stop,	
	5 pcs/strip, 0.25 - 0.5 mm ² light gray 2002-171 200 (8x25)
Insulation stop,	
	5 pcs/strip, 0.75 - 1 mm ² dark gray 2002-172 200 (8x25)

Additional advantages:

- Separation into functional and wiring level
- Modules can be replaced quickly by other types of modules

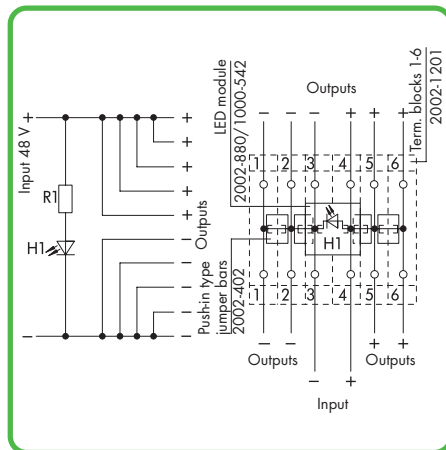

Multiple outputs with indicator lamp

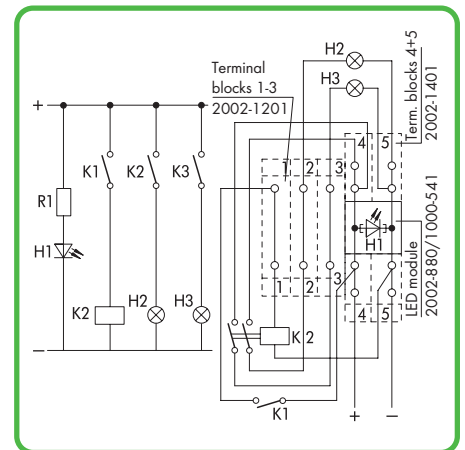









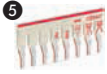



Control unit

Empty component plug housing	Empty component plug housing
Plug width 5.2 mm / 0.205 in	Plug width 10.4 mm / 0.409 in



- ① Length of 2002-1661: 66.5 mm / 2.62 in
2-conductor carrier terminal block
- ② Length of 2002-1761: 76.8 mm / 3.02 in
3-conductor carrier terminal block
- ③ Length of 2002-1861: 87.5 mm / 3.45 in
4-conductor carrier terminal block
- ④ Length of 2002-1961: 72.9 mm / 2.87 in
2-conductor carrier terminal block with additional
jumper position
- ⑤ See application notes for:
Colored push-in type jumper bars, page 101
Staggered jumper, page 104
Push-in type wire jumper, page 102

Item No.	Pack. Unit	Item No.	Pack. Unit	Accessories
Empty component plug housing type 1, 2-pole, 5.2 mm wide ● gray	2002-800 100	Empty component plug housing type 2, 2-pole, 10.4 mm wide ● gray	2002-810 50	Staggered jumper, ⑤  insulated, I _N 25 A, light gray 2-way 2002-472 100 (4x25) 3-way 2002-473 100 (4x25) 4-way 2002-474 100 (4x25) 5-way 2002-475 50 (2x25) 6-way 2002-476 50 (2x25) 7-way 2002-477 50 (2x25) 8-way 2002-478 50 (2x25) 9-way 2002-479 50 (2x25) 10-way 2002-480 50 (2x25) 11-way 2002-481 50 (2x25) 12-way 2002-482 50 (2x25)
		Empty component plug housing type 3, 4-pole, 10.4 mm wide ● gray	2002-820 50	
Carrier Term. Blocks and Accessories Appropriate marking system: WMB/Marking strips (see Section 13)				
2-conductor carrier terminal block, ①  0.25 - 2.5 (4) mm ² / AWG 22 - 12 Terminal block width 5.2 mm / 0.205 in gray	2002-1661 50	Push-in type wire jumper, ⑤  insulated, I _N 18 A, wire size 1.5 mm ² L = 60 mm	2009-412 100 (10x10)	WMB Multi marking system,  10 strips with 10 markers per card, stretchable 5 - 5.2 mm plain 793-5501 5
End and intermediate plate, 1 mm thick orange	2002-1692 100 (4x25)	L = 110 mm	2009-414 100 (10x10)	
gray	2002-1691 100 (4x25)	L = 250 mm	2009-416 100 (10x10)	WMB Multi marking system, plain,  10 strips with 10 markers per card, stretchable 5 - 5.2 mm yellow 793-5501/000-002 red 793-5501/000-005 blue 793-5501/000-006 gray 793-5501/000-007 orange 793-5501/000-012 light green 793-5501/000-017 green 793-5501/000-023 violet 793-5501/000-024 5
3-conductor carrier terminal block, ②  0.25 - 2.5 (4) mm ² / AWG 22 - 12 Terminal block width 5.2 mm / 0.205 in gray	2002-1761 50	Push-in type jumper bar, insulated, ⑤  I _N 25 A, light gray 2-way 2002-402 200 (8x25) 3-way 2002-403 200 (8x25) 4-way 2002-404 200 (8x25) 5-way 2002-405 100 (4x25) 6-way 2002-406 100 (4x25) 7-way 2002-407 100 (4x25) 8-way 2002-408 100 (4x25) 9-way 2002-409 100 (4x25) 10-way 2002-410 100 (4x25)		
End and intermediate plate, 1 mm thick orange	2002-1792 100 (4x25)			
gray	2002-1791 100 (4x25)			
4-conductor carrier terminal block, ③  0.25 - 2.5 (4) mm ² / AWG 22 - 12 Terminal block width 5.2 mm / 0.205 in gray	2002-1861 50	Push-in type jumper bar, insulated,  I _N 25 A, light gray from 1 to 3 2002-433 200 (8x25) from 1 to 4 2002-434 200 (8x25) from 1 to 5 2002-435 100 (4x25) from 1 to 6 2002-436 100 (4x25) from 1 to 7 2002-437 100 (4x25) from 1 to 8 2002-438 100 (4x25) from 1 to 9 2002-439 100 (4x25) from 1 to 10 2002-440 100 (4x25)		
End and intermediate plate, 1 mm thick orange	2002-1892 100 (4x25)			
gray	2002-1891 100 (4x25)			
2-conductor carrier terminal block, ④  0.25 - 2.5 (4) mm ² / AWG 22 - 12 Terminal block width 5.2 mm / 0.205 in gray	2002-1961 50			
End and intermediate plate, 1 mm thick orange	2002-1992 100 (4x25)			
gray	2002-1991 100 (4x25)			
Protective warning marker,  with high-voltage symbol, black, for 5 terminal blocks yellow	2002-115 100 (4x25)	Multi-purpose operating tool,  for component plugs 2002-116 5		

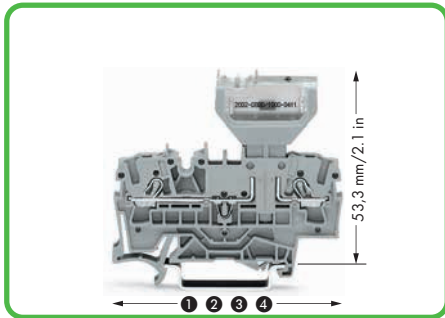

Application example showing a pluggable diode module.



Opening the cover via multi-purpose operating tool for component plugs.



When closing the cover, please insert cover as shown in the illustration.

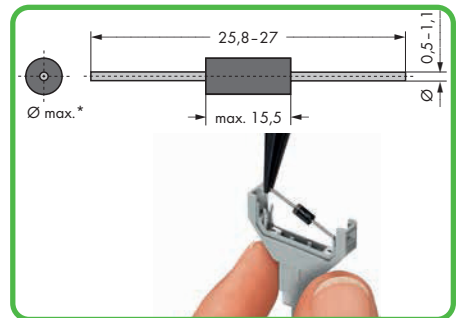

* Ø max. 3.4 mm at 5.2 mm module width and
 * Ø max. 5.4 mm at 10.4 mm module width
Notice: Reconnection only possible with similar or larger wire diameter. Smaller wire diameters must be soldered. Component plugs for building custom circuits. Solder-free assembly of diodes, resistors, etc. Picture shows 1N4007 diode.

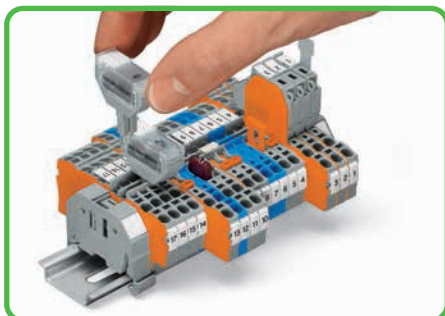

Plugging a diode module into a through terminal block.

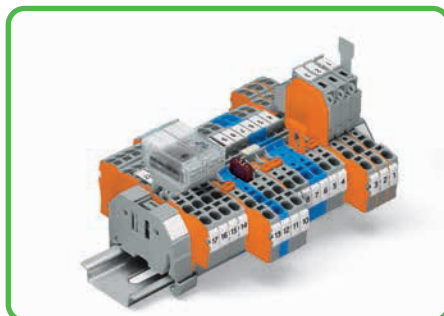

Diode module inserted in a through terminal block.

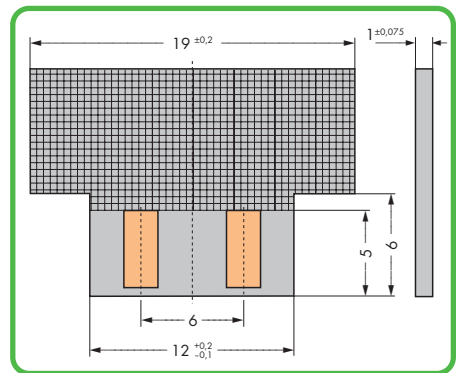

Dimensions of self-assembled PCBs
 Module height 2 mm at 5.2 mm module width and
 module height 3.3 mm at 10.4 mm module width



Cutting component to the proper length.

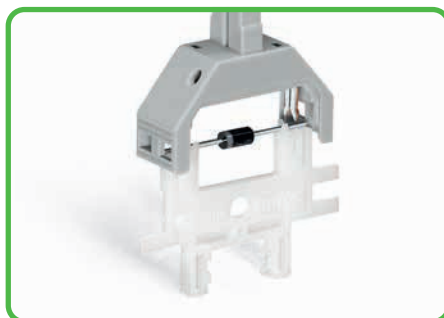

Pressing component into plug contact via operating tool.





Pushing PCB into plug contact via operating tool.









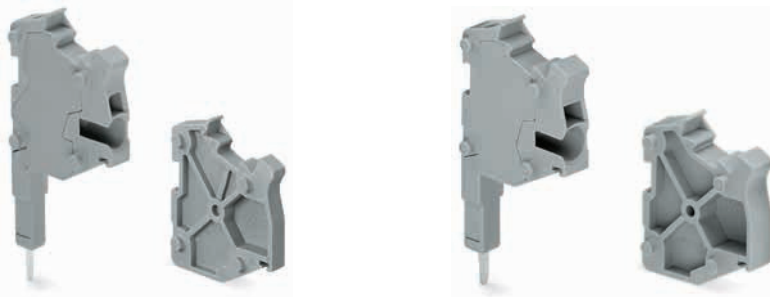



TOPJOB® S

Connectors and Connector Strips

2001/2002 Series

0.25 - 1.5 (2.5) mm ² ① AWG 22 - 14 500 V/6 kV/3 ③ I _N 18 A Terminal block width 4.2 mm / 0.165 in  9 - 11 mm / 0.39 in ④	0.25 - 2.5 (4) mm ² ② AWG 22 - 12 500 V/6 kV/3 ③ I _N 24 A Terminal block width 5.2 mm / 0.205 in  10 - 12 mm / 0.43 in ④
--	--



Item No.	Pack. Unit	Item No.	Pack. Unit	Accessories
Modular TOPJOB®S connector, for jumper contact slot, can be snapped together, gray ● 1-pole 2001-511 100 (4x25)		Modular TOPJOB®S connector, for jumper contact slot, can be snapped together, gray ● 1-pole 2002-511 100 (4x25)		Appropriate marking systems: WMB/Marking
Spacer module, can be snapped together, e.g., for bridging commoned terminal blocks ● gray 2001-549 100 (4x25)		Spacer module, can be snapped together, e.g., for bridging commoned terminal blocks ● gray 2002-549 100 (4x25)		
TOPJOB®S connector strip, for jumper contact slot, gray ● 2-pole 2001-552 25 ● 3-pole 2001-553 25 ● 4-pole 2001-554 25 ● 5-pole 2001-555 10 ● 6-pole 2001-556 10 ● 7-pole 2001-557 10 ● 8-pole 2001-558 10 ● 9-pole 2001-559 10 ● 10-pole 2001-560 10		TOPJOB®S connector strip, for jumper contact slot, gray ● 2-pole 2002-552 25 ● 3-pole 2002-553 25 ● 4-pole 2002-554 25 ● 5-pole 2002-555 10 ● 6-pole 2002-556 10 ● 7-pole 2002-557 10 ● 8-pole 2002-558 10 ● 9-pole 2002-559 10 ● 10-pole 2002-560 10		Test plug,  with 500 mm cable, 2.3 mm Ø yellow 210-137 50
Item-Specific Accessories		Item-Specific Accessories		Test plug,  with 500 mm cable, 2 mm Ø red 210-136 50
End plate,  for modular TOPJOB®S connectors, 1.5 mm thick gray 2002-541 100 (4x25)		End plate,  for modular TOPJOB®S connectors, 1.5 mm thick gray 2002-541 100 (4x25)		Strain relief plate, gray  35 mm width 734-326 100 (4x25) 6 mm wide 734-327 100 (4x25) 12.5 mm width 734-328 100 (4x25) 25 mm wide 734-329 100 (4x25)
WMB Inline, plain,  stretchable 4 - 4.2 mm, 2,000 WMB markers, 4 mm, on roll white 2009-114 1		WMB Inline, plain,  stretchable 5 - 5.2 mm, 1,500 WMB markers, 5 mm, on roll white 2009-115 1		Marking strip, plain,  11 mm wide, 50 m roll white 2009-110 1
WMB Multi marking system,  10 strips with 10 markers per card, stretchable 4 - 4.2 mm plain 793-4501 5		WMB Multi marking system,  10 strips with 10 markers per card, stretchable 5 - 5.2 mm plain 793-5501 5		
WMB Multi marking system, plain,  10 strips with 10 markers per card, stretchable 4 - 4.2 mm yellow 793-4501/000-002 red 793-4501/000-005 blue 793-4501/000-006 gray 793-4501/000-007 orange 793-4501/000-012 light green 793-4501/000-017 green 793-4501/000-023 violet 793-4501/000-024 5		WMB Multi marking system, plain,  10 strips with 10 markers per card, stretchable 5 - 5.2 mm yellow 793-5501/000-002 red 793-5501/000-005 blue 793-5501/000-006 gray 793-5501/000-007 orange 793-5501/000-012 light green 793-5501/000-017 green 793-5501/000-023 violet 793-5501/000-024 5		
		Miniature WSB Quick marking system,  10 strips with 10 markers per card, 5 mm wide markers plain 248-501 5		

- Handling - TOPJOB® S Connectors

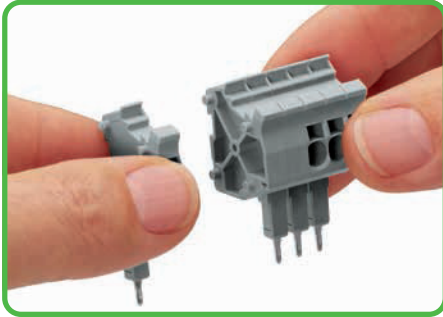

Snapping connectors and spacer modules together to assemble a multipole connector.

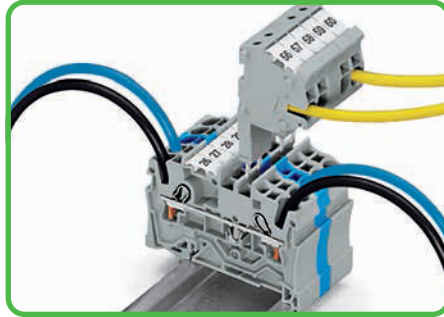

These modular connectors provide an additional connection option for conductors of the same cross section range as the terminal blocks being used.

- ❶ Conductor sizes: 0.25 mm² - 2.5 mm² "s + f-st";
Push-in conductor sizes: 0.5 mm² - 2.5 mm² "s"
and 0.75 mm² - 1.5 mm²
"insulated ferrule, 12 mm"
- ❷ Conductor sizes: 0.25 mm² - 4 mm² "s + f-st";
Push-in conductor sizes: 0.75 mm² - 4 mm² "s"
and 0.75 mm² - 2.5 mm²
"insulated ferrule, 12 mm"
- ❸ 500 V = rated voltage
6 kV = rated surge voltage
3 = pollution degree
(see Section 14)
- ❹ Strip length, see packaging or instructions.

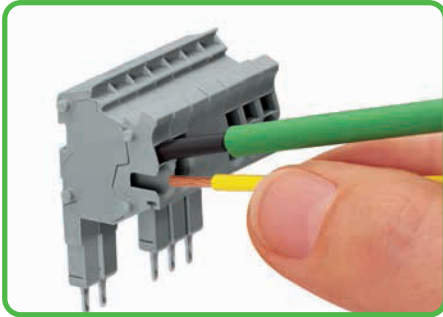

Conductor termination:
- Using an operating tool for unferruled, fine-stranded conductors
- Push-in connection of solid conductors

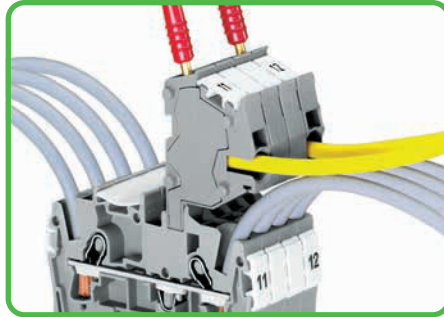

The connectors have a test socket for 2 mm Ø or 2.3 mm Ø test plugs.

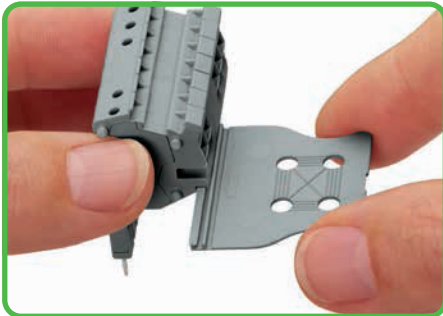

Snapping on a strain relief plate.

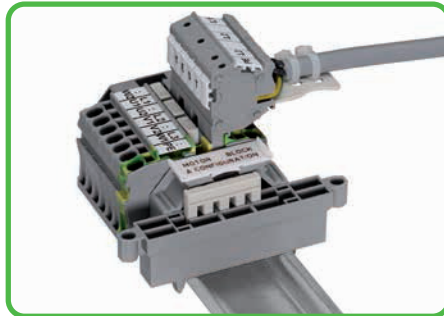





Rail-mounted terminal block assembly for electric motor wiring.

TOPJOB® S

Connectors 4 (6) mm²

2004/2006/2010/2016 Series



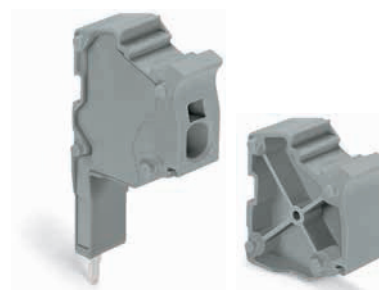

0.5 - 4 (6) mm² ① AWG 20 - 10 500 V/6 kV/3 ② 300 V, 30 A  I _N 32 A Terminal block width 6.2 mm / 0.244 in  11 - 13 mm / 0.47 in ③	0.5 - 4 (6) mm² ① AWG 20 - 10 500 V/6 kV/3 ② I _N 32 A Terminal block width 7.5 mm / 0.295 in  11 - 13 mm / 0.47 in ③	0.5 - 4 (6) mm² ① AWG 20 - 10 500 V/6 kV/3 ② I _N 32 A Terminal block width 10 mm / 0.394 in  11 - 13 mm / 0.47 in ③
--	---	--



Item No.	Pack. Unit	Item No.	Pack. Unit	Item No.	Pack. Unit
Modular TOPJOB®S connector, for jumper contact slot, can be snapped together, gray ● 1-pole 2004-511 100 (4x25)		Modular TOPJOB®S connector, for jumper contact slot, can be snapped together, gray ● 1-pole 2006-511 50 (2x25)		Modular TOPJOB®S connector, for jumper contact slot, can be snapped together, gray ● 1-pole 2010-511 50 (2x25)	
Spacer module, can be snapped together, e.g., for bridging commoned terminal blocks ● gray 2004-549 100 (4x25)		Spacer module, can be snapped together, e.g., for bridging commoned terminal blocks ● gray 2006-549 50 (2x25)		Spacer module, can be snapped together, e.g., for bridging commoned terminal blocks ● gray 2010-549 50 (2x25)	
TOPJOB®S connector strip, for jumper contact slot, gray ● 2-pole 2004-552 25 ● 3-pole 2004-553 25 ● 4-pole 2004-554 25 ● 5-pole 2004-555 10					
Item-Specific Accessories					
Test plug,  with 500 mm cable, 2.3 mm Ø yellow 210-137 50					

Accessories

Appropriate marking systems: WMB/Marking strips
(see Section 13)

End plate,  for modular TOPJOB®S connectors, 1.5 mm thick gray 2004-541 100 (4x25)	Strain relief plate, gray  35 mm width 734-326 100 (4x25) 6 mm wide 734-327 100 (4x25) 12.5 mm width 734-328 100 (4x25) 25 mm wide 734-329 100 (4x25)	Marking strip, plain,  11 mm wide, 50 m roll white 2009-110 1
Test plug,  with 500 mm cable, 2 mm Ø red 210-136 50		WMB Multi marking system,  10 strips with 10 markers per card, stretchable 5 - 5.2 mm plain 793-5501 5

TOPJOB® S

L-Type Test Plug Modules for Testing Rail-Mounted Terminal Blocks Terminal Block Width 5.2 mm via Conductor Wire Opening, 2002 Series



0.25 - 2.5 (4) mm² ① | AWG 22 - 12
500 V/6 kV/3 ②
I_N 18 A

Terminal block width 5.2 mm / 0.205 in
③ 10 - 12 mm / 0.43 in

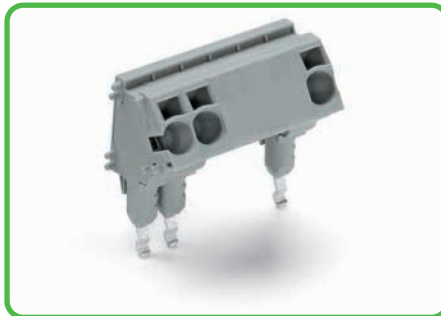

TOPJOB® S L-type test plug assembly consisting of:
L-test plug modules and spacer modules

- ① Conductor sizes: 0.25 mm² - 4 mm² "s + f-st";
Push-in conductor sizes: 0.75 mm² - 4 mm² "s"
and 0.75 mm² - 2.5 mm²
"insulated ferrule, 12 mm"
- ② 500 V = rated voltage
6 kV = rated surge voltage
3 = pollution degree
(see Section 14)
- ③ Strip length, see packaging or instructions.

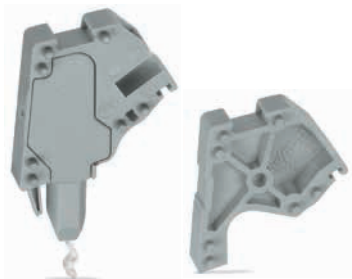

Item No.	Pack. Unit
TOPJOB® S L-test plug module , can be snapped together, gray	
According to EN 61984, connectors without current interrupting capacity shall not be mated and unmated when live or under load.	
○ 1-pole	2002-611 100 (4x25)
TOPJOB® S L-type spacer module , can be snapped together, e.g., for bridging commoned terminal blocks	
○ gray	2002-649 100 (4x25)
Accessories L-Type Test Plug Modules Appropriate marking systems: WMB/Marking strips/WMB Inline	
End plate , for modular TOPJOB® S test plugs, 1.5 mm thick	
	gray 2002-641 100 (4x25)
Test plug , with 500 mm cable, 2 mm Ø red	
	210-136 50
Test plug , with 500 mm cable, 2.3 mm Ø yellow	
	210-137 50
Strain relief plate , gray	
	35 mm width 734-326 100 (4x25)
	6 mm wide 734-327 100 (4x25)
	12.5 mm width 734-328 100 (4x25)
	25 mm wide 734-329 100 (4x25)
WMB Inline , plain, stretchable 5 - 5.2 mm, 1,500 WMB markers, 5 mm, on roll white	
	2009-115 1
WMB Multi marking system , 10 strips with 10 markers per card, stretchable 5 - 5.2 mm plain	
	793-5501 5

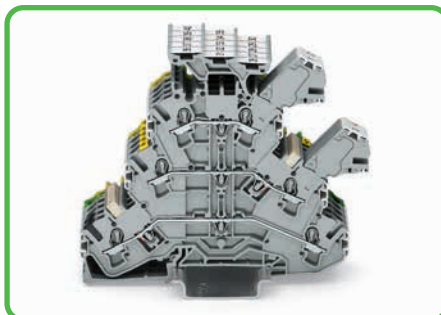

L-type test plug modules fitted in a triple-deck terminal block

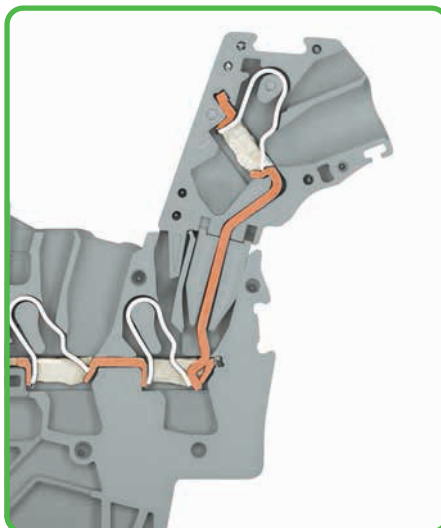

L-type test plug module, cross-sectional view of contact

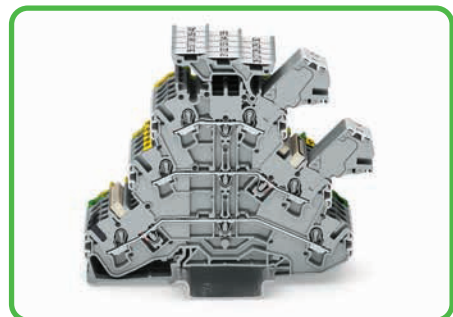

TOPJOB® S

Adjacent Jumpers for Continuous Commoning and Colored Push-In Type Jumper Bars, 2002 Series

Adjacent jumper for continuous commoning	Push-in type jumper bar	Push-in type jumper bar
--	-------------------------	-------------------------



Item No.	Pack. Unit	Item No.	Pack. Unit	Item No.	Pack. Unit	
Adjacent jumper for continuous commoning, insulated,		Push-in type jumper bar, insulated,		Push-in type jumper bar, insulated,		
I _N 25 A, light gray		I _N 25 A, red		I _N 25 A, blue		
○ 2-way	2002-400	100 (4x25)	● 2-way	2002-402/000-005	● 2-way	
			● 3-way	2002-403/000-005	● 3-way	
			● 4-way	2002-404/000-005	● 4-way	
				200 (8x25)	200 (8x25)	
			● 5-way	2002-405/000-005	● 5-way	
			● 6-way	2002-406/000-005	● 6-way	
			● 7-way	2002-407/000-005	● 7-way	
			● 8-way	2002-408/000-005	● 8-way	
			● 9-way	2002-409/000-005	● 9-way	
			● 10-way	2002-410/000-005	● 10-way	
				100 (4x25)	100 (4x25)	
			Push-in type jumper bar, insulated,		Push-in type jumper bar, insulated,	
			I _N 14 A, red		I _N 14 A, blue	
			● 2-way	2000-402/000-005	● 2-way	2000-402/000-006
			● 3-way	2000-403/000-005	● 3-way	2000-403/000-006
			● 4-way	2000-404/000-005	● 4-way	2000-404/000-006
				200 (8x25)		200 (8x25)
			● 5-way	2000-405/000-005	● 5-way	2000-405/000-006
			● 6-way	2000-406/000-005	● 6-way	2000-406/000-006
			● 7-way	2000-407/000-005	● 7-way	2000-407/000-006
			● 8-way	2000-408/000-005	● 8-way	2000-408/000-006
			● 9-way	2000-409/000-005	● 9-way	2000-409/000-006
			● 10-way	2000-410/000-005	● 10-way	2000-410/000-006
				100 (4x25)		100 (4x25)

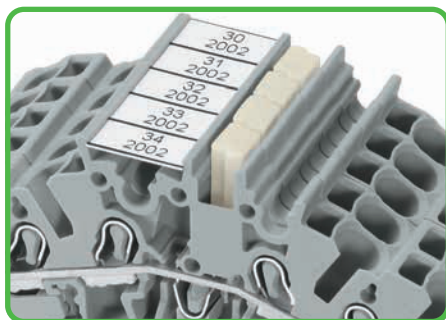

Adjacent jumpers for continuous commoning

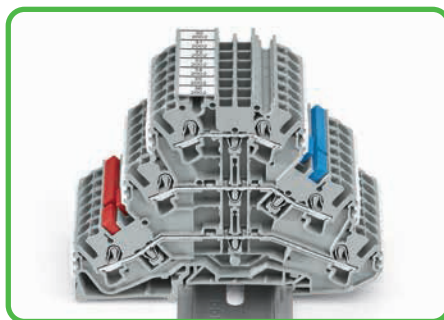

Colored push-in type jumper bars are used with sensor terminal blocks.

TOPJOB® S Push-In Type Wire Jumpers

Push-in type wire jumper I _N 9 A Conductor size 0.75 mm ²	Push-in type wire jumper I _N 18 A Conductor size 1.5 mm ²
--	--



Item No.	Pack. Unit	Item No.	Pack. Unit
Push-in type wire jumper , insulated, conductor cross section 0.75 mm ² , suitable for 2000 and 2020 Series rail-mounted terminal blocks		Push-in type wire jumper , insulated, conductor cross section 1.5 mm ² , suitable for 2001, 2002, 2003 and 2022 Series rail-mounted terminal blocks	
L = 60 mm 2009-402	100 (10x10)	L = 60 mm 2009-412	100 (10x10)
L = 110 mm 2009-404	100 (10x10)	L = 110 mm 2009-414	100 (10x10)
L = 250 mm 2009-406	100 (10x10)	L = 250 mm 2009-416	100 (10x10)

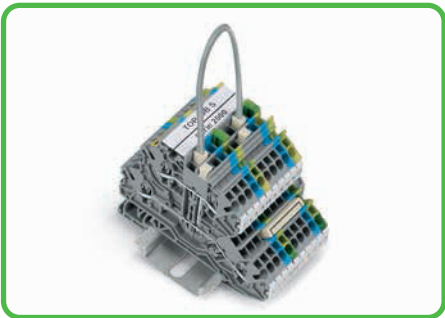

Push down the wire jumper until fully inserted.
Lift the jumper with an operating tool for rewiring.

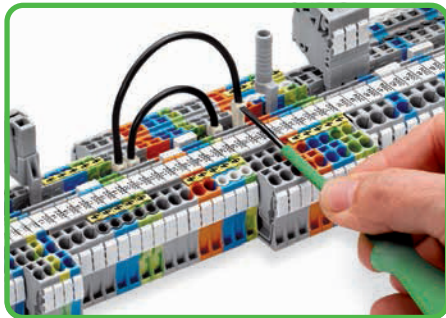

Push down the wire jumper until fully inserted.
Lift the jumper with an operating tool for rewiring.

TOPJOB® S

Star Point Jumpers and Delta Jumpers

Star point jumper 800 V/8 kV/3 $I_N = I_N$ terminal block	Delta jumper 800 V/8 kV/3 $I_N = I_N$ terminal block
--	---



Item No.	Pack. Unit	Item No.	Pack. Unit
Star point jumper, insulated,		Delta jumper, insulated,	
1-3-5,		1-2 3-4 5-6,	
light gray		light gray	
<input type="radio"/>	2000-405/011-000	<input type="radio"/>	2000-406/020-000
<input type="radio"/>	2001-405/011-000	<input type="radio"/>	2001-406/020-000
<input type="radio"/>	2002-405/011-000	<input type="radio"/>	2002-406/020-000
<input type="radio"/>	2004-405/011-000	<input type="radio"/>	2004-406/020-000
	100 (4x25)		100 (4x25)
<input type="radio"/>	2006-405/011-000		
<input type="radio"/>	2010-405/011-000		
<input type="radio"/>	2016-405/011-000		
	50 (2x25)		

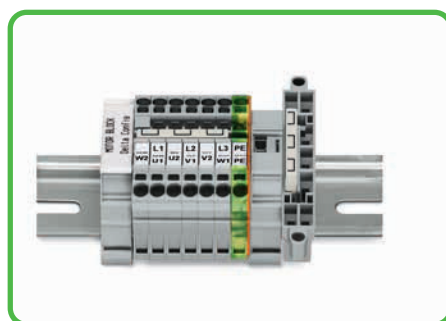
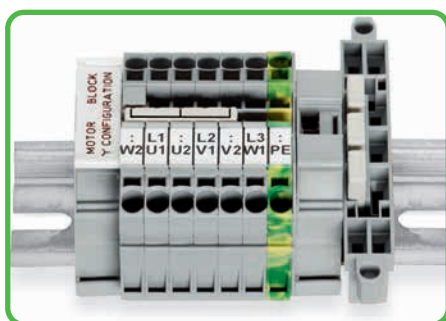

This jumper has been specially developed to create a "star point" and is used on motor terminal boards equipped with TOPJOB®S rail-mount terminal blocks.

This jumper has been specially developed to create a "delta" configuration and is used on motor terminal boards equipped with TOPJOB®S rail-mounted terminal blocks.

TOPJOB® S Staggered Jumpers 2002 Series

Staggered jumper
400 V/6 kV/3
I_N 25 A

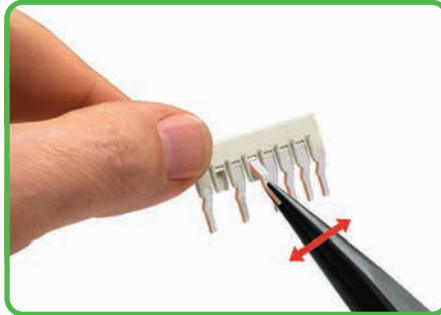

Staggered jumper with 7 contacts
Breaking off contact lugs - Individual jumper contacts can be broken off by bending them. The remaining piece of insulation will meet requirements for clearances and creepage distances.

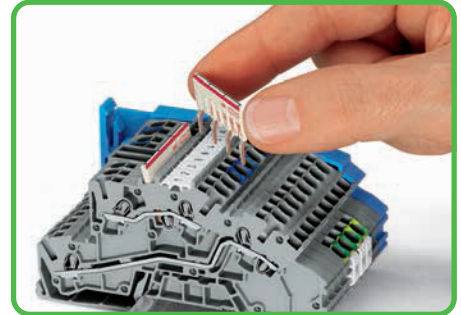

Insert staggered jumper
Push staggered jumper down until fully inserted.

Item No.	Pack. Unit
Staggered jumper, insulated, suitable for 2002, 2003 and 2022 Series rail-mounted terminal blocks, light gray	
○ 2-way	2002-472 100 (4x25)
○ 3-way	2002-473 100 (4x25)
○ 4-way	2002-474 100 (4x25)
○ 5-way	2002-475 50 (2x25)
○ 6-way	2002-476 50 (2x25)
○ 7-way	2002-477 50 (2x25)
○ 8-way	2002-478 50 (2x25)
○ 9-way	2002-479 50 (2x25)
○ 10-way	2002-480 50 (2x25)
○ 11-way	2002-481 50 (2x25)
○ 12-way	2002-482 50 (2x25)

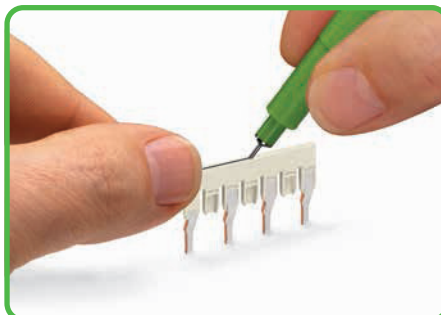

Staggered jumper 1 - 3 - 5 - 7
Marking with a felt-tip pen.

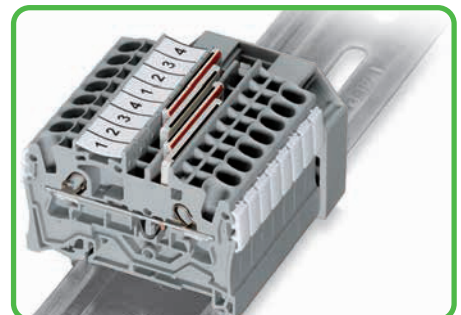

Locate red stripes of the staggered jumpers on the inside

Commoning using staggered jumpers

Individual jumper contacts can be broken off by bending them. The remaining piece of insulation will meet the requirements for clearances and creepage distances. This makes it possible to create custom staggered jumpers, e.g. for bridging over a terminal block with a different potential. When creating the jumpers, ensure only one contact lug is in contact with the terminal block. The contact lugs of the customized staggered jumpers contact the terminal blocks via the gaps created in the second jumper. Insert and press jumper into the jumper slot until it hits the backstop.

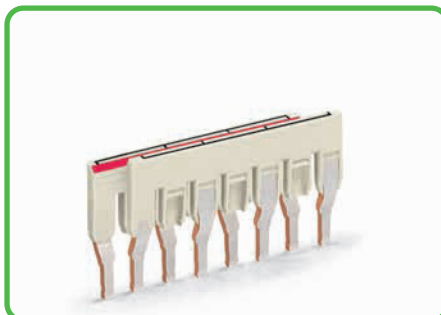

Jumpers staggered in a jumper slot
Custom staggered jumpers can be created, e.g., for bridging over a terminal block with a different potential. Make sure only one contact lug is in contact with the terminal block.

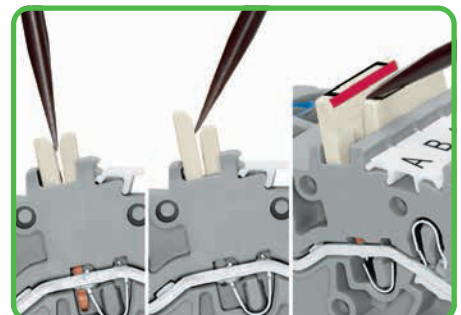

Staggered jumper removal
Insert the operating tool between the jumpers and lift up the jumper.

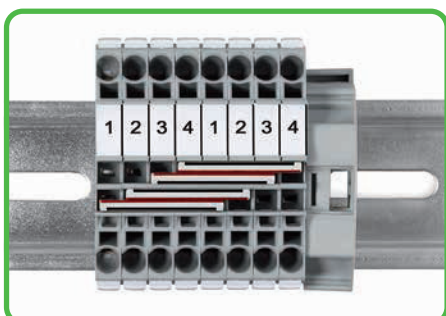

Staggered jumpers for sophisticated circuit requirements.

That way, staggered jumpers are created with contact lugs that will make contact to the terminal block in the gaps of the second jumper. Insert the ready-made jumper assembly into the jumper slot until it hits the stop.

TOPJOB® S Vertical Jumpers 2000 and 2002 Series

Double-deck vertical jumper 500 V/6 kV/3 I _N 13.5 A	Double-deck vertical jumper 500 V/6 kV/3 I _N 24 A	Triple-deck vertical jumper 500 V/6 kV/3 I _N 24 A
--	--	--



Item No.	Pack. Unit	Item No.	Pack. Unit	Item No.	Pack. Unit
Double-deck vertical jumper, insulated		Double-deck vertical jumper, insulated		Triple-deck vertical jumper, insulated	
○ light gray 2000-492	100 (4x25)	○ light gray 2002-492	100 (4x25)	○ light gray 2002-493	100 (4x25)
		● orange 2002-492/000-012	100 (4x25)		

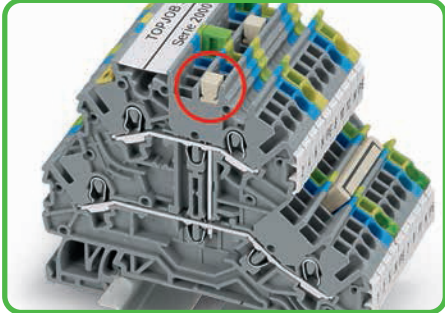

Double-deck vertical jumper, inserted.

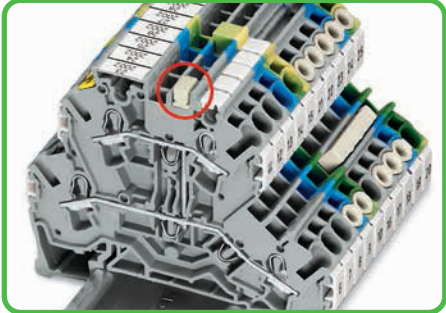

Double-deck vertical jumper, inserted.

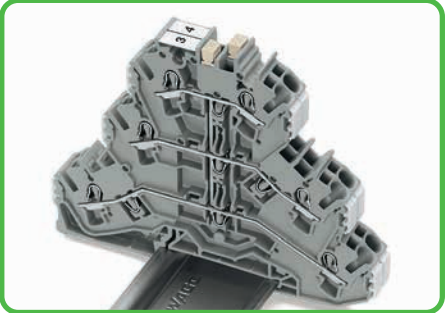

Triple-deck vertical jumper, inserted.

TOPJOB[®] S Disconnect Plugs for Carrier Terminal Blocks

Disconnect plug for carrier terminal blocks 400 V/6 kV/3 I _N 10 A	Disconnect plug for carrier terminal blocks 800 V/8 kV/3 I _N 30 A
--	--



Item No.	Pack. Unit	Item No.	Pack. Unit
Disconnect plug for carrier terminal blocks, suited when using a carrier terminal block as disconnect terminal block		Disconnect plug for carrier terminal blocks, suited when using a carrier terminal block as disconnect terminal block	
orange ●	2002-401	100 (4x25)	orange ●
		2006-401	100 (4x25)

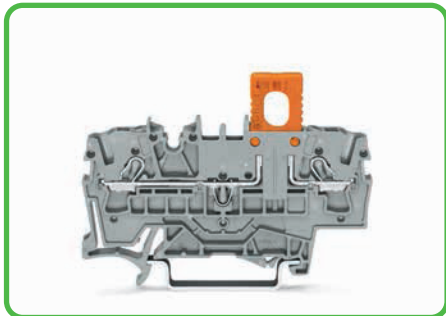

Carrier terminal block with disconnect plug in operating position.

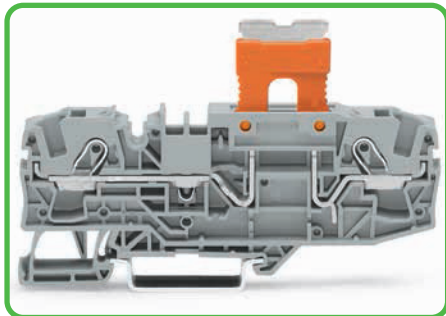

Carrier terminal block with disconnect plug in parked position.

TOPJOB® S
Lockout Caps

Lockout cap

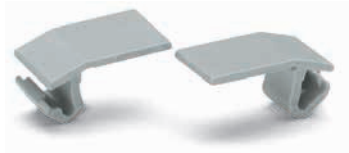

	Item No.	Pack. Unit
Lockout cap, for conductor entry hole and operating slot		
<input type="radio"/> gray	2006-191	25

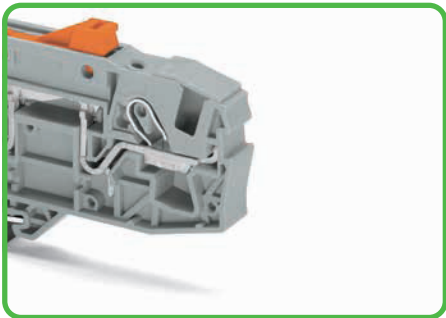

Lockout cap for covering unused clamping units of 2006 Series TOPJOB®S terminal blocks.

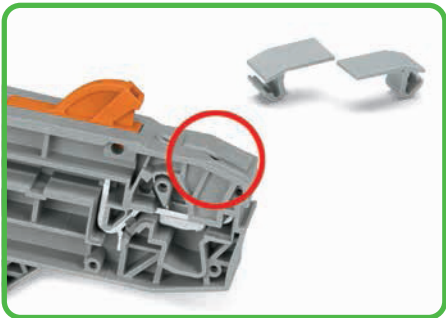

Lockout cap for covering unused clamping units of 2006 Series TOPJOB®S terminal blocks.

TOPJOB® S
WMB Inline, Mini-WSB Inline and Marking Strips

WMB Inline	Mini-WSB Inline	Marking strip
-------------------	------------------------	----------------------



Similar to picture



Item No.	Pack. Unit	Item No.	Pack. Unit	Item No.	Pack. Unit
WMB Inline , plain, stretchable 5 - 5.2 mm, 1,500 WMB markers, 5 mm, on roll ○ white 2009-115 1		Mini-WSB Inline , plain, stretchable 5 - 5.2 mm, 1,700 WMB markers, 5 mm, on roll ○ white 2009-145 1		Marking strip , plain, 11 mm wide, white ○ 50 m roll 2009-110 1	
WMB Inline , plain, stretchable 5 - 5.2 mm, 8,000 WMB markers, 5 mm, on roll ○ white 2009-135 1					
WMB Inline , plain, stretchable 4 - 4.2 mm, 2,000 WMB markers, 4 mm, on roll ○ white 2009-114 1					

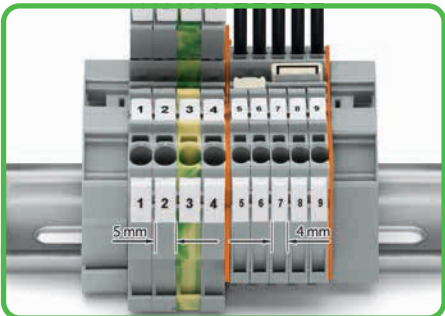

WMB Inline
2009-115 markers for 5 - 5.2 mm wide terminal blocks compared to 2009-114 markers for 4 - 4.2 mm wide terminal blocks



WMB Inline
WMB markers on roll

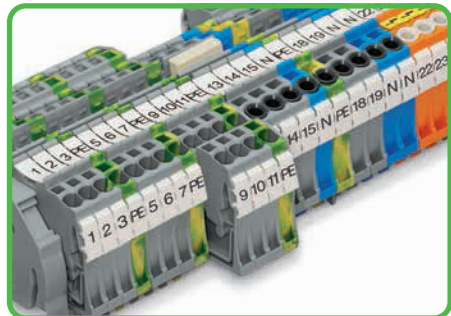

Marker strips for center marking

TOPJOB® S

Group Marker Carriers and Marker Carriers

Group marker carrier	Marker carrier
----------------------	----------------

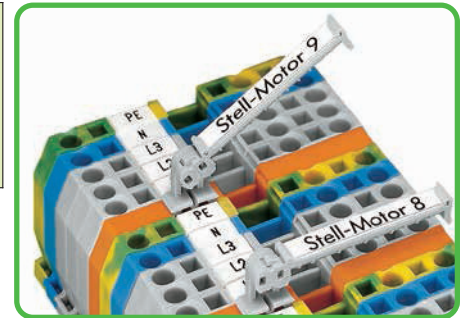

This pivoting group marker carrier has been developed for group marking of rail-mount terminal blocks to satisfy several customer requirements:

- Can be used in all multiprofile marker slots for rail-mount terminal blocks from 5 mm on or in spacer housings as shown above.
- Improves marking visibility due to difficult mounting conditions by pivoting into one of seven stable positions.

Item No.	Pack. Unit	Item No.	Pack. Unit
TOPJOB®S group marker carrier, snap-on type for jumper slot, gray		Marker carrier, for jumper slots 2002 Series, 5 mm wide	
○ 5 mm wide 2009-191	50 (2x25)	○ gray 2002-161	100 (4x25)
○ 10 mm wide 2009-192	50 (2x25)		
○ 15 mm wide 2009-193	50 (2x25)		
TOPJOB®S group marker carrier, snap-on type for jumper slot, gray			
○ 10 mm wide 2009-196	50 (2x25)		

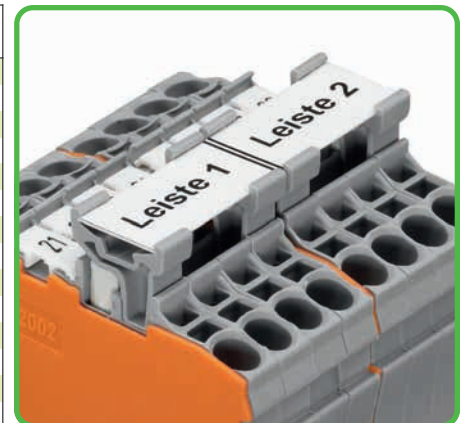

Marking strip carriers
for use in jumper slots

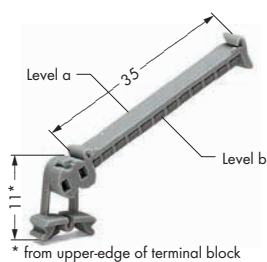

Item No.	Pack. Unit	Item No.	Pack. Unit
Pivoting group marker carrier		Marker carrier, for lateral marker receptacle, 5 mm wide	
○ gray 249-105	50 (2x25)	○ gray 2009-198	200 (8x25)
Marker card, 4 x 30 markers per sheet			
○ white 209-183	1		
Protection cover			
transparent 209-184	50		



Marking strip carriers
for use in lateral marker slots

TOPJOB® S

Ferrules for Rail-Mounted Terminal Blocks and Crimping Tools



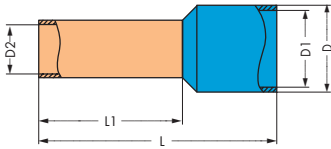





Ferrule, insulated, tin-plated, electrolytic copper, gastight crimped	Variocrimp 4 crimping tool for insulated and uninsulated ferrules 0.25 mm ² - 4 mm ² /AWG 24 - 12	Variocrimp 16 crimping tool for insulated and uninsulated ferrules 6 mm ² - 16 mm ² /AWG 10 - 6
---	---	---



Item No.	Pack. Unit	Item No.	Pack. Unit	Item No.	Pack. Unit	
Ferrule, insulated, according to DIN 46228, part 4/09.90		Variocrimp 4 crimping tool, 0.25 mm ² - 4 mm ² /AWG 24 - 12		Variocrimp 16 crimping tool, 6 mm ² - 16 mm ² /AWG 10 - 6		
○ white	216-241	1000	206-204	1	206-216	1
○ gray	216-242	1000				
○ gray	216-262	1000				
● red	216-243	1000				
● red	216-263	1000				
● black	216-244	1000				
● black	216-264	1000				
● black	216-284	1000				
● blue	216-246	1000				
● blue	216-266	1000				
● blue	216-286	1000				
○ gray	216-267	1000				
○ gray	216-287	500				
● yellow	216-208	100				
● yellow	216-288	500				
● blue	216-289	500				
● blue	216-210	100				

Ferrules

Technical Data

Ferrule, insulated,	Ferrule, insulated,	Ferrule, insulated,
 sleeve for 0.5 mm ² /AWG 22, 12 mm strip length, L: 16 mm, L1: 10 mm, D: 3.1 mm, D1: 2.6 mm, D2: 1 mm white 216-241	 sleeve for 1 mm ² /AWG 18, 12 mm strip length, L: 16 mm, L1: 10 mm, D: 3.5 mm, D1: 3 mm, D2: 1.4 mm red 216-243	 sleeve for 1.5 mm ² /AWG 16, 14 mm strip length, L: 18 mm, L1: 12 mm, D: 4 mm, D1: 3.5 mm, D2: 1.7 mm black 216-264
 sleeve for 0.75 mm ² /AWG 20, 12 mm strip length, L: 16 mm, L1: 10 mm, D: 3.3 mm, D1: 2.8 mm, D2: 1.2 mm gray 216-242	 sleeve for 1 mm ² /AWG 18, 14 mm strip length, L: 18 mm, L1: 12 mm, D: 3.5 mm, D1: 3 mm, D2: 1.4 mm red 216-263	 sleeve for 1.5 mm ² /AWG 16, 20 mm strip length, L: 24 mm, L1: 18 mm, D: 4 mm, D1: 3.5 mm, D2: 1.7 mm black 216-284
 sleeve for 0.75 mm ² /AWG 20, 14 mm strip length, L: 18 mm, L1: 12 mm, D: 3.3 mm, D1: 2.8 mm, D2: 1.2 mm gray 216-262	 sleeve for 1.5 mm ² /AWG 16, 12 mm strip length, L: 16 mm, L1: 10 mm, D: 4 mm, D1: 3.5 mm, D2: 1.7 mm black 216-244	 sleeve for 2.5 mm ² /AWG 14, 12 mm strip length, L: 17 mm, L1: 10 mm, D: 4.7 mm, D1: 4.2 mm, D2: 2.2 mm blue 216-246











Insert ferruled conductor into crimping station.



Squeeze handles until ratchet mechanism is released.

Application notes:

- With "Variocrimp 4," the built-in crimping pressure control automatically adjusts force to the conductor cross section used. With "Variocrimp 16," it is necessary to select the wire gauge on the tool before crimping.
- Only one crimping station is needed to handle the specified conductor size range.
- Uniform compact crimping from all four sides for high conductor retention.
- No need to center the conductor into the ferrule.
- Conductor and ferrule insertion possible from both sides (for left- and right-handers).
- Built-in ratchet mechanism ensures gastight crimp connection.
- Crimping tools open automatically after crimping operation is complete.
- Comfortable handles for operator.

Ferrules	
Technical Data	
<p>Ferrule, insulated,</p>  <p>Sleeve for 2.5 mm² / AWG 14, 14 mm strip length, L: 19 mm, L1: 12 mm, D: 4.7 mm, D1: 4.2 mm, D2: 2.2 mm blue 216-266</p>	<p>Ferrule, insulated,</p>  <p>Sleeve for 10 mm² / AWG 8, 20 mm strip length, L: 28 mm, L1: 18 mm, D: 8.4 mm, D1: 7.6 mm, D2: 4.5 mm blue 216-289</p>
<p>Ferrule, insulated,</p>  <p>Sleeve for 2.5 mm² / AWG 14, 20 mm strip length, L: 25 mm, L1: 18 mm, D: 4.7 mm, D1: 4.2 mm, D2: 2.2 mm blue 216-286</p>	<p>Ferrule, insulated,</p>  <p>Sleeve for 16 mm² / AWG 6, 23 mm strip length, L: 29 mm, L1: 18 mm, D: 9.6 mm, D1: 8.8 mm, D2: 5.8 mm blue 216-210</p>
<p>Ferrule, insulated,</p>  <p>Sleeve for 4 mm² / AWG 12, 14 mm strip length, L: 20 mm, L1: 12 mm, D: 5.4 mm, D1: 4.8 mm, D2: 2.8 mm gray 216-267</p>	
<p>Ferrule, insulated,</p>  <p>Sleeve for 4 mm² / AWG 12, 20 mm strip length, L: 26 mm, L1: 18 mm, D: 5.4 mm, D1: 4.8 mm, D2: 2.8 mm gray 216-287</p>	
<p>Ferrule, insulated,</p>  <p>Sleeve for 6 mm² / AWG 10, 14 mm strip length, L: 20 mm, L1: 12 mm, D: 6.8 mm, D1: 6.2 mm, D2: 3.5 mm yellow 216-208</p>	
<p>Ferrule, insulated,</p>  <p>Sleeve for 6 mm² / AWG 10, 20 mm strip length, L: 26 mm, L1: 18 mm, D: 6.9 mm, D1: 6.3 mm, D2: 3.5 mm yellow 216-288</p>	

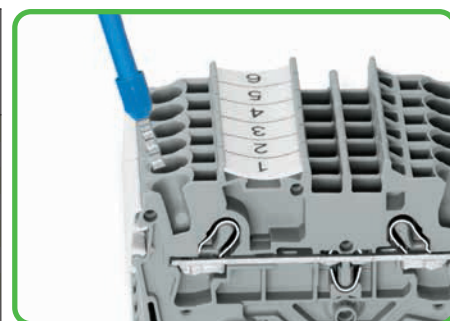

Stranded conductors with ferrules

from at least two sizes below the rated cross section up to the rated cross section can be simply pushed in – without tools.

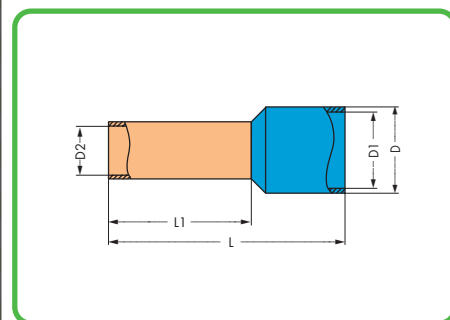

For dimensions of insulated ferrules, see technical data.