



# Wireless Technology

## Wireless Technology

- Bluetooth®
- WLAN
- EnOcean®

## Section 9 ▶

### TO-PASS® telecontrol technology

- For applications that go beyond site boundaries
- Telecontrol technology based on GSM/GPRS

		<b>Page</b>	
<b>General Product Information</b>		540	
<b>Interfaces and Configurations</b>		541	
<b>Description</b>		<b>Item No.</b>	
<b>Bluetooth® Application and Installation Instructions</b>		542	
		750-644	544
		758-915	545
		757-801	546
		750-921	547
<b>WLAN Application and Installation Instructions</b>		548	
		758-916	549
	<ul style="list-style-type: none"> <li>• 2.4 GHz</li> <li>• 5 GHz</li> </ul>	758-917	
<b>EnOcean® Application and Installation Instructions</b>		550	
		789-601	551
	<ul style="list-style-type: none"> <li>• 4-Channel Radio Receiver, 4 Make Contact, 16 A</li> <li>• 4-Channel Radio Receiver, 4 Changeover Contact, 8 A</li> </ul>	789-602	
		770-629/101-000	552
	<ul style="list-style-type: none"> <li>• 4-Channel Radio Receiver, 4 Make Contact</li> <li>• 2-Channel Radio Receiver, Sunblind Outputs</li> </ul>	770-629/102-000	
		750-642	553
		758-940/001-000	554
	<ul style="list-style-type: none"> <li>• 2-Channel Lighting Control</li> <li>• 4-Channel Lighting Control</li> <li>• 2-Channel Blind Control</li> <li>• 4-Channel Blind Control</li> </ul>	758-940/003-000	
	<ul style="list-style-type: none"> <li>• 2-Channel Blind Control</li> <li>• 4-Channel Blind Control</li> </ul>	758-940/002-000	
	<ul style="list-style-type: none"> <li>• 4-Channel Blind Control</li> </ul>	758-940/004-000	
	<b>Accessories</b>		
			555

### Wireless Technology in the Industrial Environment

Wireless technology can support wired applications or enable completely new applications. In mobile or movable systems, wireless technology is the first choice when greater distances or obstacles must be overcome. It is an alternative for applications in which wired solutions are not economical or technically feasible.

Various wireless technologies can be used depending on the application.



**Bluetooth® – Robust, Flexible, High-Performance**

Well-known in consumer electronics, *Bluetooth®* technology is also well-suited to industrial use with its internationally approved frequency range, a very robust transmission technology (frequency hopping), real-time response and a range of up to 1000 m. It makes wireless process data communication between two stations possible (point-to-point communication), and also enables the setup of a piconet in which a *Bluetooth®* master can communicate with up to seven slaves, e.g., decentralized mobile sensors. In addition, *Bluetooth®* can be used as the radio system for commissioning.

Features:

- Secure transmission (encrypted)
- AFH (Adaptive Frequency Hopping)
- Adaptive transmission power
- Uses the license-free 2.4GHz frequency band

### GPRS for Remote Connections

For applications that go beyond site boundaries, *TO-PASS®* telecontrol technology provides the right solution. More detailed information on *TO-PASS®* is available in Section 9.



**WLAN – Full IT Integration**

WLAN makes it easy to setup a wireless transmission link for ETHERNET protocols. This can be standard ETHERNET protocols, e.g., for communication between a smartphone and automation components. Industrial fieldbus protocols such as PROFINET, MODBUS/TCP or Ethernet/IP can also be used to link mobile equipment with stationary equipment. Ranges up to 400 m are possible depending on the transmission technology used.



**enocean®**

**EnOcean® – The Radio Standard in Building Automation**

Wireless switches and sensors based on EnOcean® technology harvest available energy to power themselves, e.g., kinetic energy from actuating a switch or sensors powered by ambient light. This energy harvesting completely eliminates maintenance of the radio transmitter at a range of up to 300 m in open air (30 m in buildings).

- Always the right radio system for the industry and application
- Industrial design: high-performance, robust and safe
- Tightly integrated into WAGO automation technology



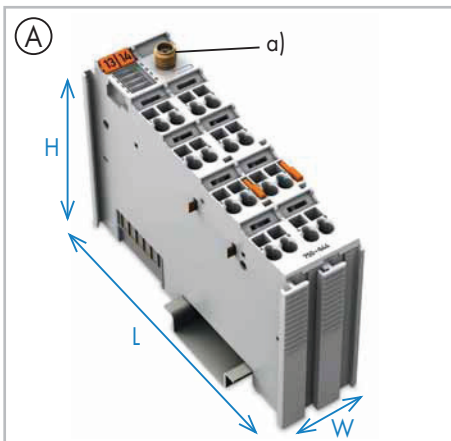

**Communication Module for I/O-System (A)**

- For use with
  - Programmable fieldbus controllers (PFC)
  - Fieldbus coupler (FC) I/O-System 750 Series
- Antenna connection (a)
- W x H x L (mm) 24 x 64 x 100, height from upper edge of DIN-rail, plus approx. 6.5 mm of excess length with antenna socket

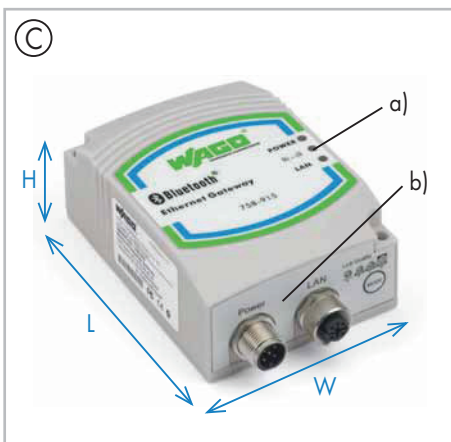

**Radio Adapter (B)**

- For use with
  - PFC, 750 XTR Series PFC, FC, 750 XTR Series FC
  - JUMPFLEX® Signal Conditioners, 2857 + 857 Series
- Integrated antenna
- Diagnostic LED (a)
- W x H x L (mm) 15 x 50 x 19

**ETHERNET Gateway (C)**

- Integrated converter from ETHERNET protocols to radio technology
- Integrated antenna
- Diagnostic LEDs (a)
- Connections with M12 pluggable connectors (b)
- Degree of protection: IP65
- W x H x L (mm) 66 x 36.2 x 91

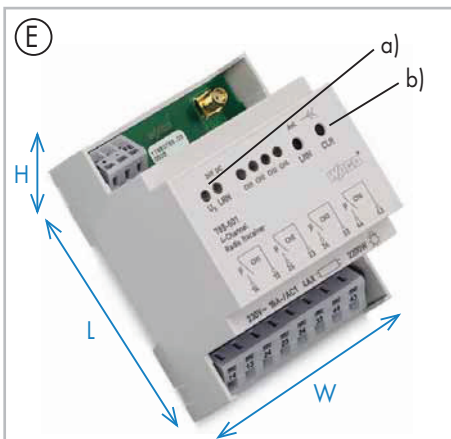
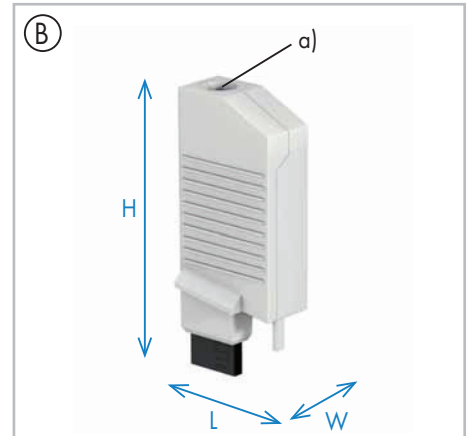

**RS-232, IP67 Module (D)**

- Bluetooth® / RS-232 converter
- Diagnostic LEDs (a)
- Connecting cable
- Degree of protection: IP67
- W x H x L (mm) 30 x 20 x 117

**DIN-Rail Mount Enclosure (E)**

- For installation in sub-distribution panels
- Diagnostic LEDs (a)
- Learn (LRN) button, Clear (CLR) button (b)
- Degree of protection: IP20
- W x H x L (mm) 70 x 55 x 90

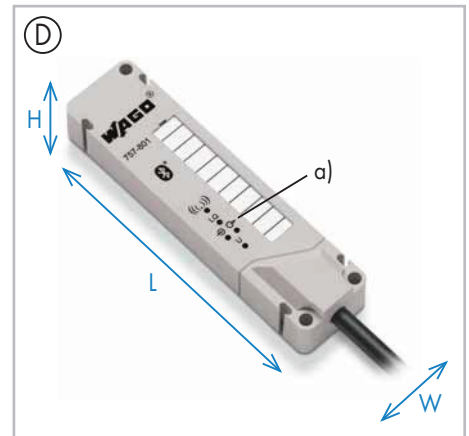

**WINSTA® Pluggable Connection System (F)**

- Ready-to-use functional unit for building automation
- For wall, floor and ceiling mounting
- Complete pluggable connection technology
- Degree of protection: IP20
- W x H x L (mm) 195 x 145 x 30
- More information on WINSTA® in the catalog volume 5

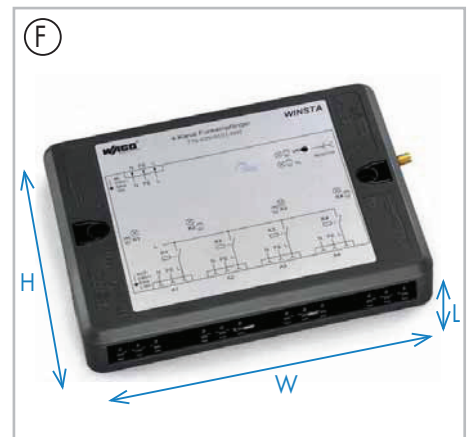

**Contact Units (G)**

- Universal contact units for standard switch series in building automation
- Compatible with manufacturer programs from BERKER, GIRA, JUNG, MERTEN



**Wireless Engineering**

- Commissioning, maintenance
- For connecting WAGO software on a PC/notebook to a product's service interface
- Programmable fieldbus controller
- Programmable fieldbus controller XTR
- Fieldbus coupler I/O-System 750
- Fieldbus coupler I/O-System 750 XTR
- Temporary install via compact Bluetooth® adapter
- Permanent installation with high degree of protection

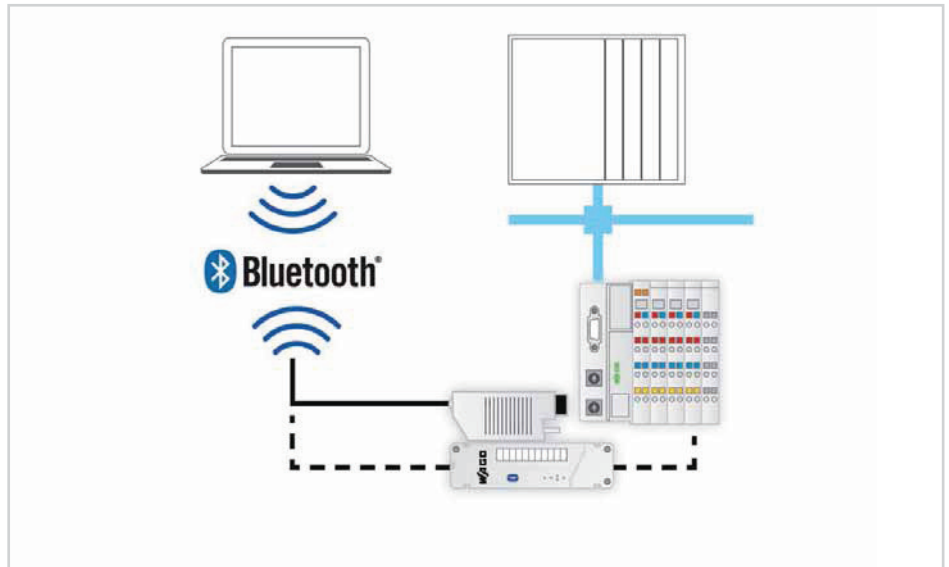

**Integration of Mobile Sensors/Actuators**

- Data exchange between up to eight modules
- Radio transmitter/receiver in the I/O module
- Operation on
  - Programmable fieldbus controllers
  - Fieldbus couplers
- Cycle time < 30 ms
- Range up to 1000 m in open air

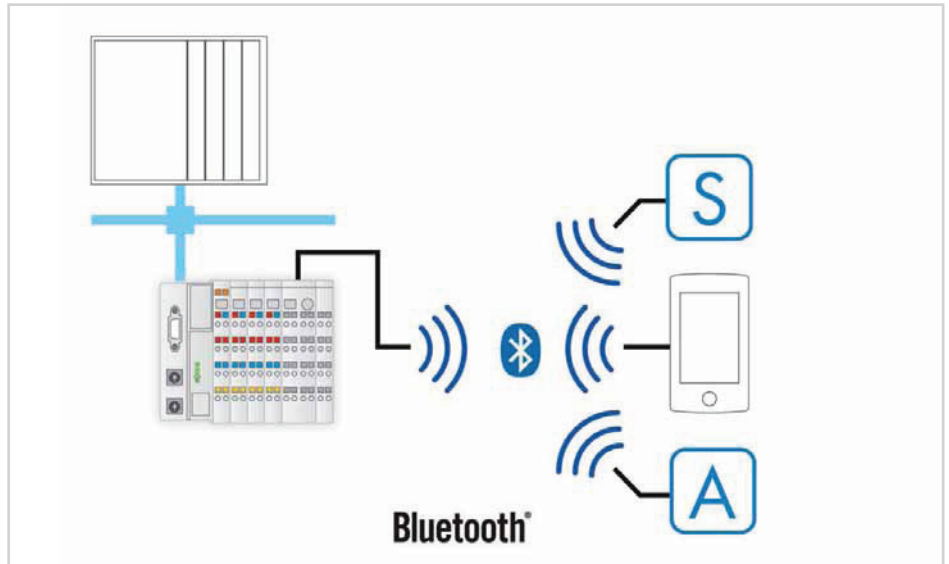

**Coupling of Mobile Systems and Data Exchange between Two or More Stations**

- Fieldbus-independent coupling of I/O stations (up to eight) or programmable fieldbus controllers
- Example: for coupling a mobile unit with a stationary basic system
- Or for wireless data exchange between several stations over long distances
- Process data coupling
- Cycle time < 30 ms
- Range up to 1000 m in open air

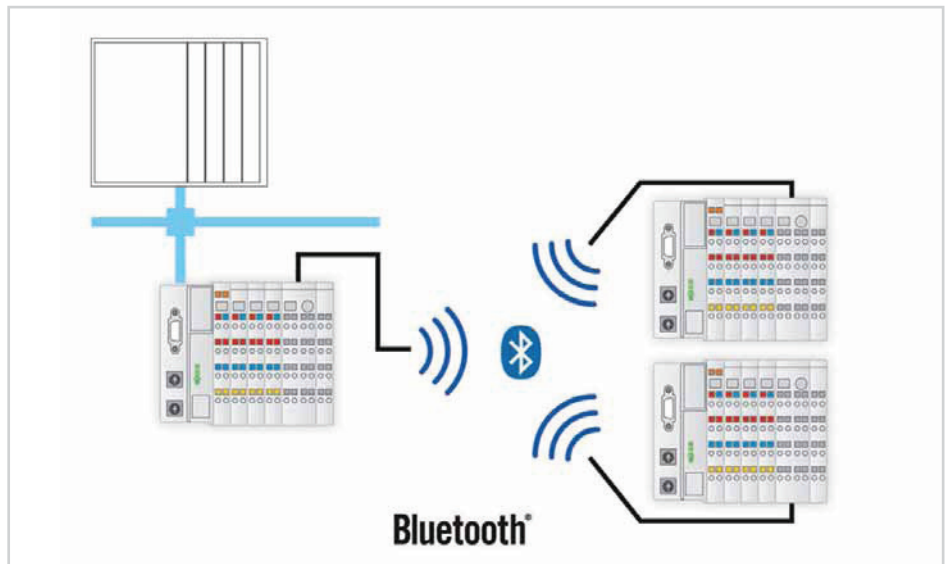

### Tunneling of ETHERNET Fieldbuses

- Point-to-point connection, e.g., connecting mobile units to a central controller or for connecting fixed stations
- Tunneling PROFINET, MODBUS/TCP, Ethernet/IP, etc. via Bluetooth® wireless technology
- Process data coupling
- Range up to 400 m in open air

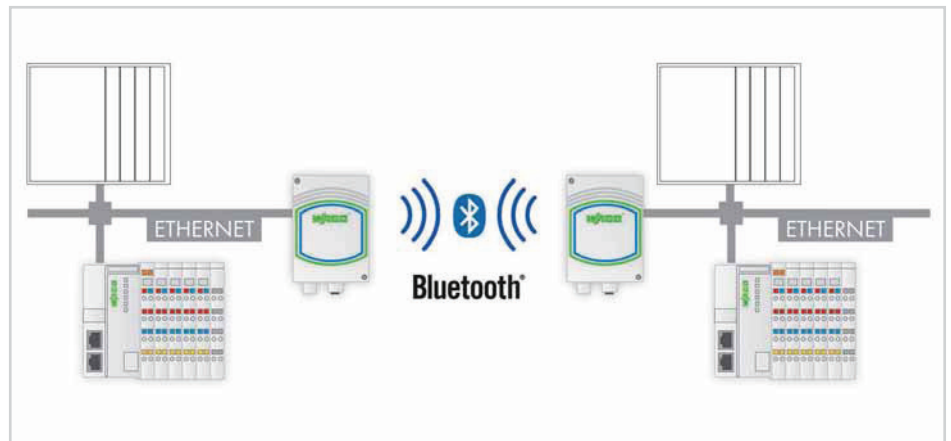

### Coupling of Mobile Systems (IP67)

- Fieldbus-independent coupling of I/O stations or programmable fieldbus controllers
- Example: for coupling a mobile unit with a stationary basic system
- Process data coupling
- Range up to 100 m in open air

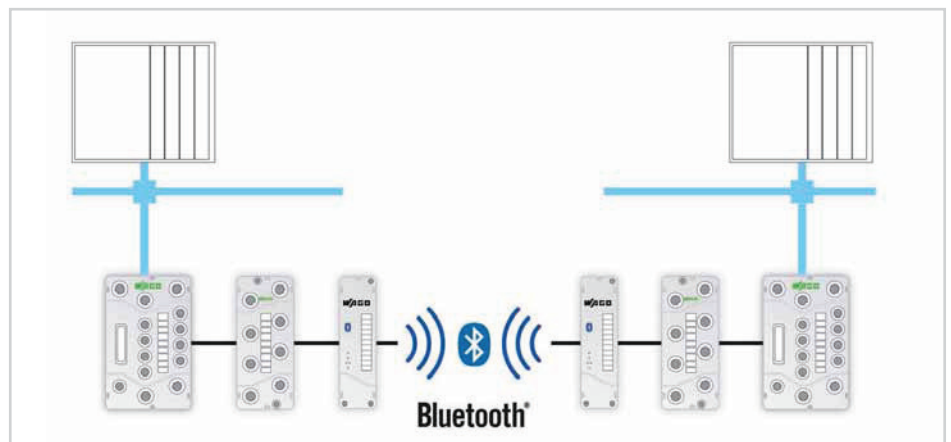

### Coupling of Mobile Systems

- Tunneling ETHERNET telegrams via Bluetooth® wireless technology
- Point-to-point connection, e.g., for coupling a mobile unit with a stationary basic system
- Process data coupling
- Range up to 400 m in open air

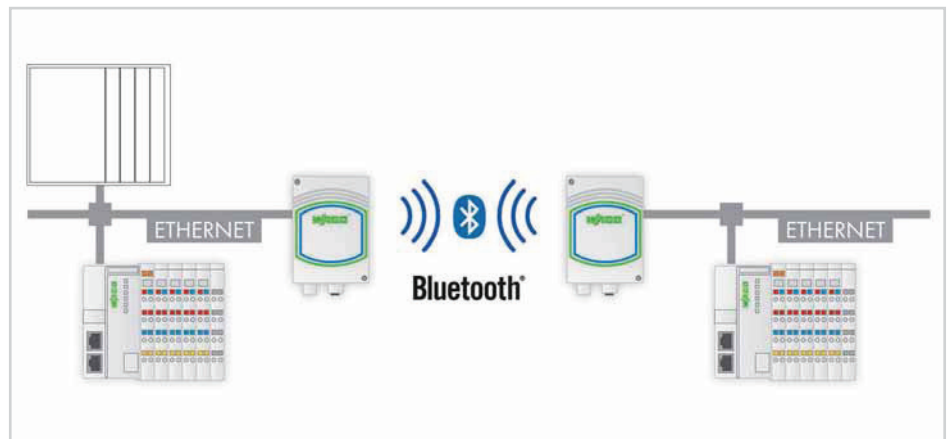

### Radio Connection for Serial Devices

- Coupling of standard devices with RS-232 interface
- Example: printer to a mobile unit controlled by a stationary basic system
- Or to a portable RFID reader
- Range up to 100 m in open air

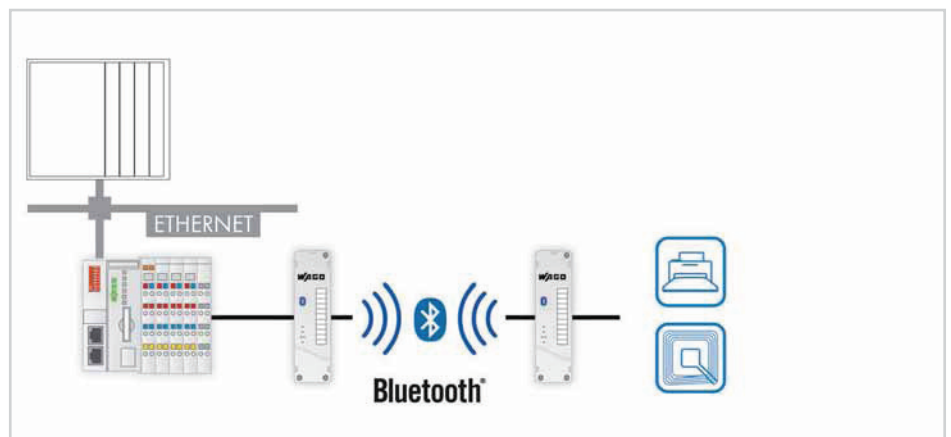

# Bluetooth®/RF Transceiver

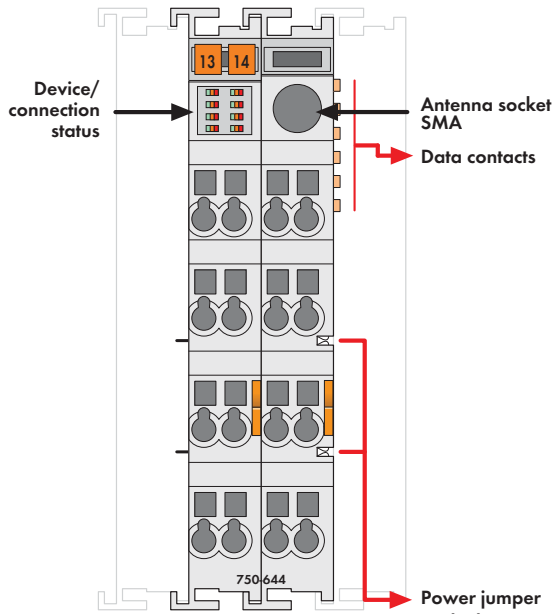

Delivered without miniature WSB markers

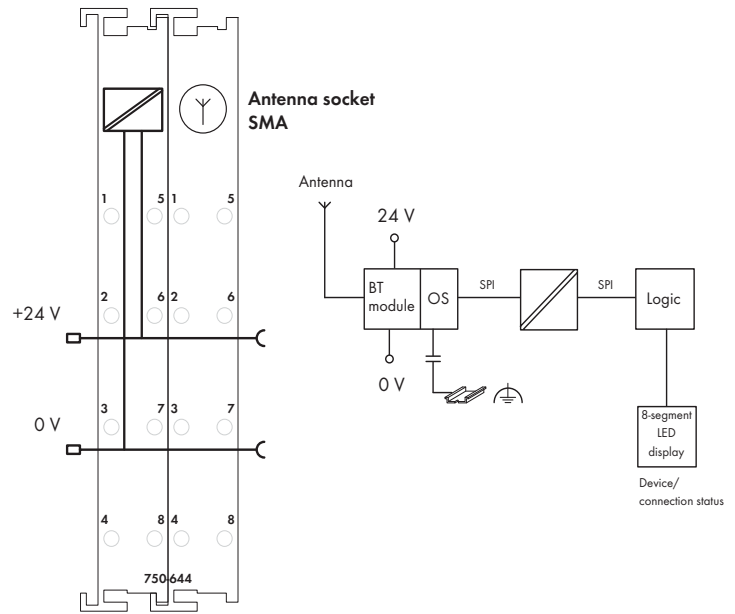



The 750-644 I/O Module permits the wireless exchange of process data with up to seven other devices via Bluetooth® 2.0 radio technology. Interoperability with Bluetooth devices is made non-proprietary via PAN and SPP Bluetooth® profiles. A special profile for time-sensitive applications is also available.

The I/O module can be operated with all standard fieldbus couplers/controllers from the WAGO-I/O-SYSTEM 750. Module configuration is performed locally via WAGO-I/O-CHECK.

Reliable connections over distances of up to 1000m are possible using the WAGO 758-912 external antenna.

The module's extended diagnostic functions include cyclic and acyclic state information. For quick on-site diagnostics, main information on operational status and radio connection is also displayed via 8 LEDs.

Description	Item No.	Pack. Unit
Bluetooth®/RF Transceiver	750-644	1
<b>Accessories</b>		
<b>Miniature WSB Quick marking system</b>		
 plain	248-501	5
with marking	see Section 11	
<b>External antenna</b> WLAN/Bluetooth 2.4 GHz	758-912	1
<b>Approvals</b>		
<b>FC</b>	FCC approval (This device complies with part 15 of FCC rules)	
<b>Bluetooth</b>	Bluetooth® approval	
Conformity marking	CE	
Korea Certification		
UL 508		
ANSI/ISA 12.12.01	Class I, Div. 2, Grp. ABCD, T4	
TÜV 07 ATEX 554086 X	I M2 Ex d I Mb, II 3 G Ex nA IIC T4 Gc, II 3 D Ex tc IIIC T135°C Dc	
Permissible ambient temperature	0 °C ... +60 °C	
IECEx TUN 09.0001 X	Ex d I Mb, Ex nA IIC T4 Gc, Ex tc IIIC T135°C Dc	
Permissible ambient temperature	0 °C ... +60 °C	

Technical Data	
Wireless technology	Bluetooth® 2.0 + EDR
Topology	Piconet (1 master, max. 7 slaves)
Coexistence	AFH and adaptive transmission power
Profiles	SPP, PAN
Operating modes	Communication mode with ad-hoc profile for high connectivity and real-time profile for time-critical applications, as well as configuration mode
Frequency band	2402-2480 MHz (license-free ISM band)
Transmitter power	up to 20 dBm (Bluetooth® Class 1)
Receiver sensitivity	-94 dBm
Transmission range	max. 1000 m in open field, 100 m in buildings (using a WAGO external antenna, item no. 758-912)
Voltage supply (Bluetooth)	via 24 V DC field supply
Voltage supply (internal)	via system voltage DC/DC
Current consumption (Bluetooth)	approx. 8 mA, max. 35 mA
Current consumption (internal)	approx. 20 mA
Isolation	500 V antenna/system
Internal bit width	12, 24, 48 bytes configurable; incl. 1 byte control/status
Diagnostics (via visual indicator)	Device status, connection status <sup>1)</sup>
Diagnostics (via process image)	Device status, connection status <sup>1)</sup> , time monitoring
Configuration	WAGO-I/O-CHECK and WAGO-I/O-PRO CAA
Dimensions (mm) W x H x L	24 x 64* x 100; *+ excess length of the SMA socket approx. 6.5 mm
Weight	85 g
EMC immunity of interference	acc. to EN 61000-6-2, EN 61131-2
EMC emission of interference	acc. to EN 61000-6-3, EN 61131-2

<sup>1)</sup> Quality of radio connection, signal strength, interference

# Bluetooth® ETHERNET Gateway

Wireless transmission link for ETHERNET protocols



#### Power connector:

M12 plug, A-coded



- 1: Vin + (DC 9 ... 30 V)
- 2: External Trigger Ground
- 3: Vin GND (0 V)
- 4: External Trigger + (DC 9 ... 30 V)
- 5: n.c.

#### ETHERNET connector:

M12 socket, D-coded



- 1: Transmit +
- 2: Receive +
- 3: Transmit -
- 4: Receive -

The 758-915 Bluetooth® ETHERNET gateway simplifies creation of a wireless transmission link for ETHERNET protocols (e.g., PROFINET, MODBUS/TCP, Ethernet/IP).

The gateway is used as a cable substitute to create a robust, industry-proven Bluetooth® 2.0 link between two automation devices.

The IP65 housing and circularly polarized antenna allow the gateway to be used even in harsh industrial environments. Simple, push-button operation provides very fast connection between two Bluetooth® ETHERNET gateways. Additional settings can be made via Web-based management.

Bluetooth® Adaptive Frequency Hopping (AFH) and Low Emission Mode™ provide excellent coexistence with other wireless systems, such as WLAN.

#### Note:

Two Bluetooth® ETHERNET gateways are required to establish a point-to-point connection.

Description	Item No.	Pack. Unit
Bluetooth® ETHERNET Gateway	758-915	1
Accessories	Item No.	
IP67 cables and connectors	see Section 11	
Approvals		
Standards/specifications	R&TTE (Europe)	
	FCC/CFR 47 part 15	
	IC (Industry Canada)	
Conformity marking	CE	

Technical Data	
Wireless technology	Bluetooth® 2.0
Topology	Point-to-point connection
Coexistence	AFH, Low Emission Mode™
Profiles supported	Generic Access Profile (GAP), Personal Area Networking Profile (PANU, NAP)
Frequency band	License-free ISM band, 2402-2480 MHz
Transmission range	up to 400 m (class 1)
Antenna	Internal, circularly polarized, directional antenna
Voltage supply	24 V DC
Voltage range	9 V ... 30 V DC
Current consumption	46 mA at 24 V DC
Ports	<b>ETHERNET connector:</b> M12 socket, D-coded <b>Power connector:</b> M12 plug, A-coded
Configuration	Simple, push-button operation and Web-based management
Number of inputs	1 (trigger input)
Dimensions (mm) W x H x L	66 x 36.2 x 91
Weight	120 g
Operating temperature	-30 °C ... +65 °C
Storage temperature	-40 °C ... +85 °C
Degree of protection	IP65
EMC immunity of interference	acc. to EN 61000-6-2
EMC emission of interference	acc. to EN 61000-6-3





WAGO's 757-801 Bluetooth® Module wirelessly connects a serial interface to external Bluetooth® devices (e.g., PCs/notebooks with Bluetooth®). Data is exchanged via Bluetooth® SPP (Serial Port Profile).

Substitute cabling between two serial devices by automatically restoring the outgoing wireless connection (e.g., to a second Bluetooth® module). High protection class provides enhanced, wireless Bluetooth® module's installation outside of control cabinets.

Coexistence properties:

- AFH (Adaptive Frequency Hopping)
- Adaptive transmission power with configurable upper limits for data exchange and device discovery
- Configurable channel blacklist for FHSS (Frequency Hopping Spread Spectrum)
- Coexistence optimized device discovery supported (media allocation < 5 %, allocation duration < 100 ms)

Description	Item No.	Pack. Unit
Bluetooth® Module	757-801	1
<b>Accessories</b>		
	Item No.	
Marking strips, felt-tip pen	see Section 10	
<b>Approvals</b>		
Conformity marking	CE	
 Bluetooth	Bluetooth® approval	
<b>Technical Data</b>		
Version	2.1	
Radio class	Class 1/max. 100 m	
Antenna	integrated	
RF output power	max. +10 dBm	
RF input sensitivity	typ. -82 dBm	
Frequency range	2.402 ... 2.483 GHz (ISM band)	
Type of communication	Point-to-point connection	
Profiles supported	Serial Port Profile (SPP)	
Security encryption	Bluetooth® security mode 4 "Secure Simple Pairing" 128-bit encryption	
Dimensions (mm) W x H x L	30 x 20 x 117 (without cable)	
Weight	418 g	
Fixing	Screw mounting	
Ports	RS-232 interface (RX/TX) with hardware flow control (CTS/RTS) Bluetooth® radio interface	

Technical Data	
Baud rate	9600 ... 115200 bps
Indicators	five LEDs
Voltage supply	+24 VDC
Voltage range	+10 V ... +32 VDC
Current input (at 24 VDC)	< 50 mA
EMC immunity of interference	acc. to EN 61000-6-2
EMC emission of interference	acc. to EN 61000-6-3
Permissible temperature range	-20 °C ... +60 °C (static); -5 °C ... +60 °C (moving)
Storage temperature	-30 °C ... +80 °C
Degree of protection	IP67
Connecting cable	
Cable length	5 m
Cable design	Outer sheath PUR halogen-free Black
Cable Ø	6.6 mm (± 0.2 mm)
Screening	Copper braiding, tin-plated, 0.10 mm single-wire diameter
Conductor design	4 x 0.34 mm <sup>2</sup> + 2 x 0.75 mm <sup>2</sup> conductor 0.34 mm <sup>2</sup> , extra-fine stranded, 43 x 0.10 mm conductor 0.75 mm <sup>2</sup> , extra-fine stranded, 21 x 0.205 mm color identification of conductors
Bending radius	10 x cable diameter for flexible application
Bending cycles	1 million cycles



#### Bluetooth® Adapter in Connection with 750 Series

The Bluetooth® Adapter wirelessly connects a notebook computer with Bluetooth® functionality to the service interface of the buscoupler/controller. It also provides an active connection to a programmable fieldbus controller. As a cable substitute, the Bluetooth® Adapter allows communication between two fieldbus controllers, as well as between fieldbus couplers/controllers via WAGO software tools (e.g., WAGO-I/O-CHECK, WAGO-I/O-PRO). Configurable coexistence properties ensure trouble-free operation in the presence of other radio systems.

#### Bluetooth® Adapter in Connection with 857 Series

The Bluetooth® Adapter wirelessly connects a notebook computer with Bluetooth® functionality to the service interface of a configurable 857 Series JUMPFLEX® Module. As a cable substitute, the Bluetooth® Adapter allows communication between JUMPFLEX® Modules and WAGO software tool (WAGOframe) or configuration APP for Android-based end devices.

If required, adapter configuration may be performed via AT commands. The adapter is supplied via both service interface and power supply of coupler/controller or JUMPFLEX® module.

Description	Item No.	Pack. Unit
Bluetooth® Adapter	750-921	1
<b>Approvals</b>		
Conformity marking	CE	
 Bluetooth®	Bluetooth® approval	

Technical Data	
Data transfer rate	9600 ... 115000 bps
Frequency range	2.4 ... 2.4835 GHz (ISM band)
Type of communication	Point-to-point connection
Profiles supported	Serial Port Profile (SPP)
Version	2.1
Radio class	Class 2
RF output power	max. +4 dBm (class 2)
RF input sensitivity	typ. -82 dBm
Antenna	integrated
Ports	4-pole service connectors
Configuration	AT commands (e.g. via Hyper Terminal)
Function	Master or Slave
LED	Operating status
Operating temperature	-20 °C ... +60 °C
Current consumption (internal)	60 mA
Security authentication	PIN code or configurable access list
Security encryption	128-bit encryption
Dimensions (mm) W x H x L	15 x 50 x 19
Weight	7 g
Coexistence	Frequency Hopping Spread Spectrum (FHSS), Adaptive Frequency Hopping (AFH), Adaptive transmission power with configurable upper limit, configurable channel blacklist, supports coexistence optimized inquiry (transmission time ≤ 0.1 s; transmission cycle ≥ 2.9 s)

# 8 WLAN Wireless Technology

## Application and Installation Instructions

### Wireless Engineering

- Commissioning, maintenance
- For connections between a notebook and automation system

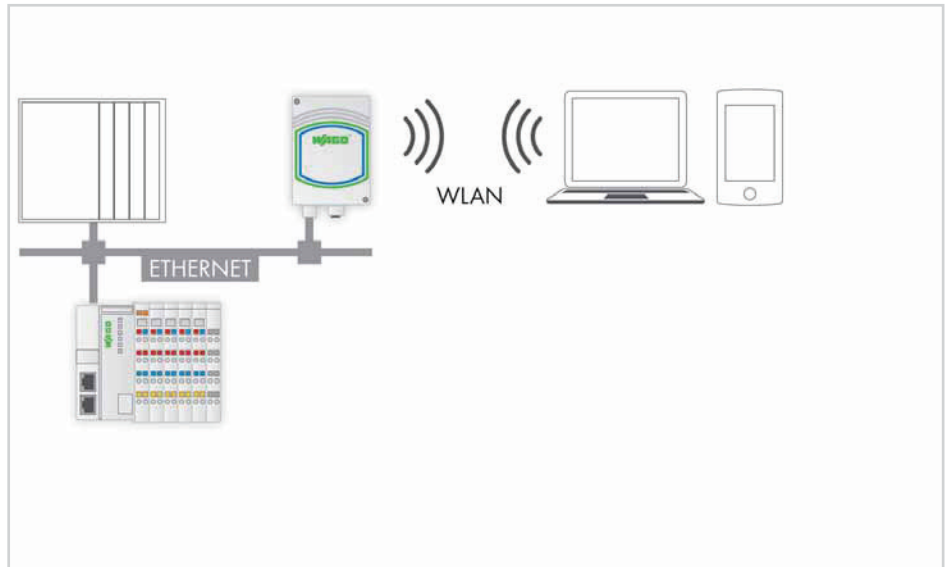

### Coupling of Mobile Systems

- Point-to-point connection, e.g., for coupling a mobile unit with a stationary basic system
- Tunneling ETHERNET telegrams via WLAN wireless technology
- Process data coupling
- Range up to 400 m in open error (frequency band 2.4 GHz)
- Range up to 200 m in open error (frequency band 5 GHz)



### Tunneling of ETHERNET Fieldbuses

- Point-to-point connection, e.g., for connecting mobile units to a central controller
- Tunneling PROFINET, MODBUS/TCP, Ethernet/IP, etc. via WLAN wireless technology
- Process data coupling
- Range up to 400 m in open error (frequency band 2.4 GHz)
- Range up to 200 m in open error (frequency band 5 GHz)

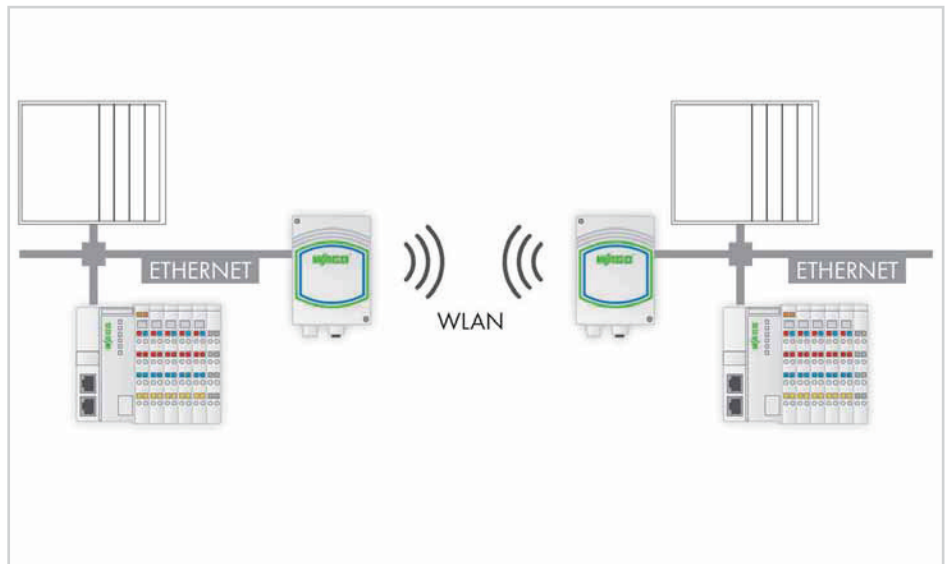

# WLAN ETHERNET Gateway

Wireless transmission link for ETHERNET protocols



#### Power connector:

M12 plug, A-coded



- 1: Vin + (DC 9 ... 30 V)
- 2: External Trigger Ground
- 3: Vin GND (0 V)
- 4: External Trigger + (DC 9 ... 30 V)
- 5: n.c.

#### ETHERNET connector:

M12 socket, D-coded



- 1: Transmit +
- 2: Receive +
- 3: Transmit -
- 4: Receive -

WAGO WLAN ETHERNET Gateways simplify creation of a wireless transmission link for ETHERNET protocols (e.g., PROFINET, MODBUS/TCP, Ethernet/IP).

The gateway is used as a cable substitute to create a robust, industry-proven WLAN link between two automation devices.

The IP65 housing and circularly polarized antenna allow the gateway to be used even in harsh industrial environments. Simple, push-button operation provides very fast connection between two WLAN ETHERNET Gateways.

#### Note:

Two WLAN ETHERNET Gateways of the same type are required to establish a point-to-point connection.

Description	Item No.	Pack. Unit
WLAN ETHERNET Gateway, 2.4 GHz	758-916	1
WLAN ETHERNET Gateway, 5 GHz	758-917	1
Accessories	Item No.	Pack. Unit
IP67 cables and connectors	see Section 11	
Approvals		
Standards/specifications	R&TTE (Europe)	
	FCC/CFR 47 part 15	
	IC (Industry Canada)	
Conformity marking	CE	

Technical Data	
Wireless technology	IEEE 802.11 bgn (758-916) IEEE 802.11 an (758-917)
Topology	Point-to-point connection
Security authentication	Open, Shared, WPA/WPA2 PSK, LEAP, PEAP
Security encryption	None, WEP64, WEP128, TKIP, AES/CCMP
Frequency band	License-free ISM band, 2.4 GHz (758-916) License-free ISM band, 5 GHz (758-917)
Transmission range	up to 400 m (758-916) up to 200 m (758-917)
Antenna	Internal, circularly polarized, directional antenna
Voltage supply	24 V DC
Voltage range	9 V ... 30 V DC
Ports	<b>ETHERNET connector:</b> M12 socket, D-coded <b>Power connector:</b> M12 plug, A-coded
Configuration	Simple, push-button operation and Web-based management
Number of inputs	1 (trigger input 9 V ... 30 VDC)
Dimensions (mm) W x H x L	66 x 36.2 x 91
Weight	120 g
Operating temperature	-30 °C ... +65 °C
Storage temperature	-40 °C ... +85 °C
Degree of protection	IP65
EMC immunity of interference	acc. to EN 61000-6-2
EMC emission of interference	acc. to EN 61000-6-3



**Stand-Alone Solution for DIN-Rail Mounting**

- Radio receiver in DIN-rail mount enclosure
- 4-channel radio receiver modules in 70 mm DIN-rail mount enclosure
- Relay outputs in different versions
- Range up to 300 m in open air, approx. 30 m in buildings

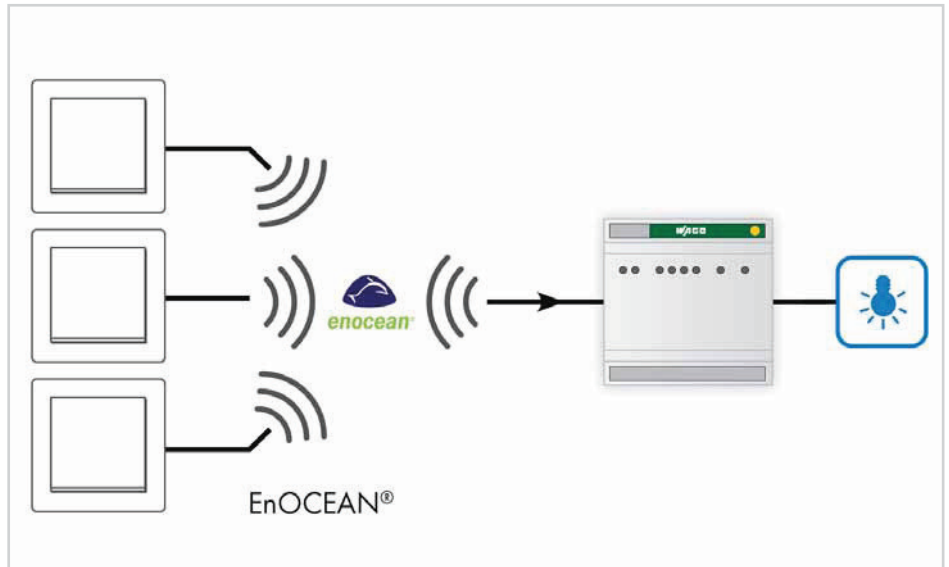

**Pluggable Installation with WINSTA®**

- Various designs, e.g., fully integrated blind control
- 4-channel lighting control
- For wall, floor and ceiling mounting
- Range up to 300 m in open air, approx. 30 m in buildings
- More information on WINSTA® in the catalog volume 5

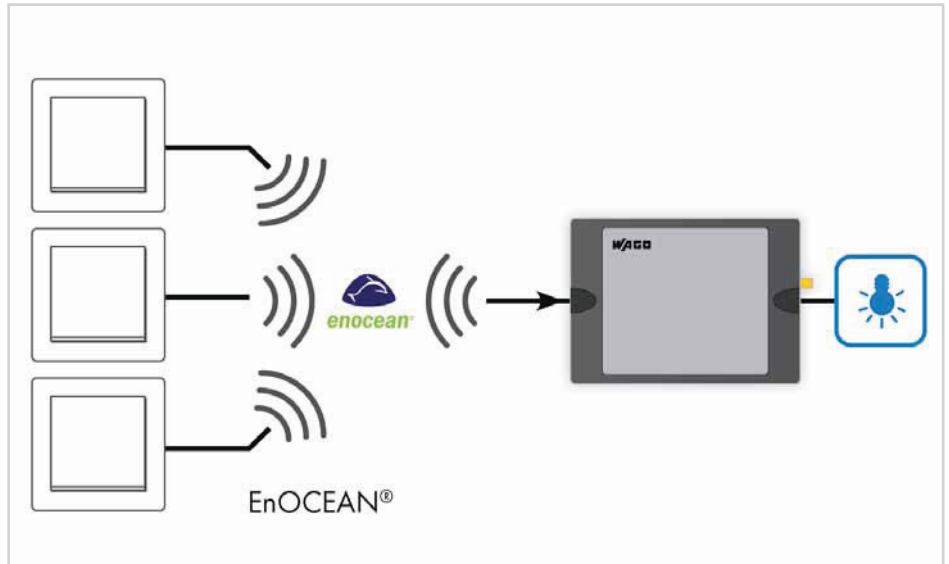

**Integration into the WAGO-I/O-SYSTEM**

- Receiver in the Bus Module
- Operation on
  - Programmable fieldbus controllers
  - Fieldbus couplers
- Range up to 300 m in open air, approx. 30 m in buildings

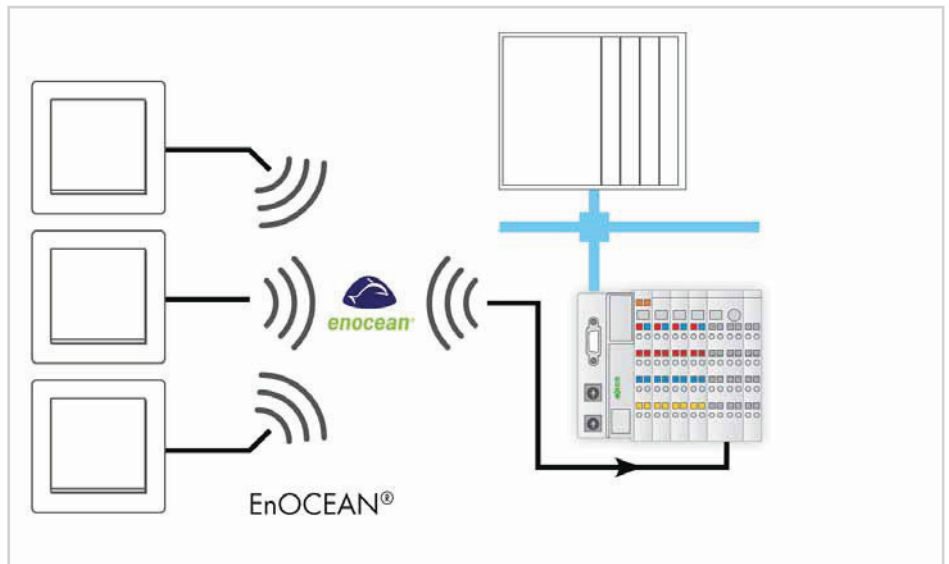

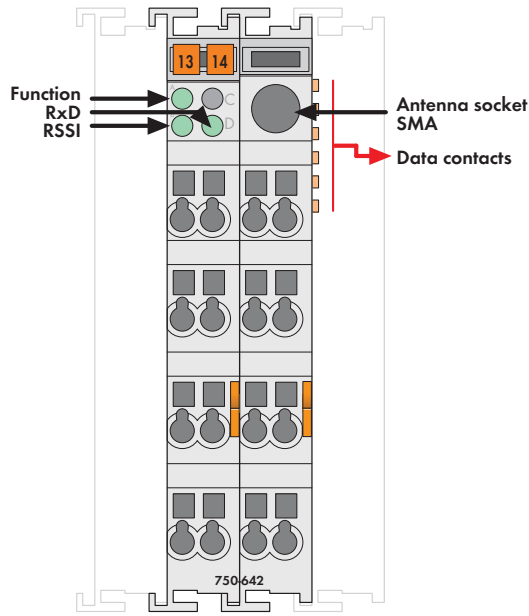

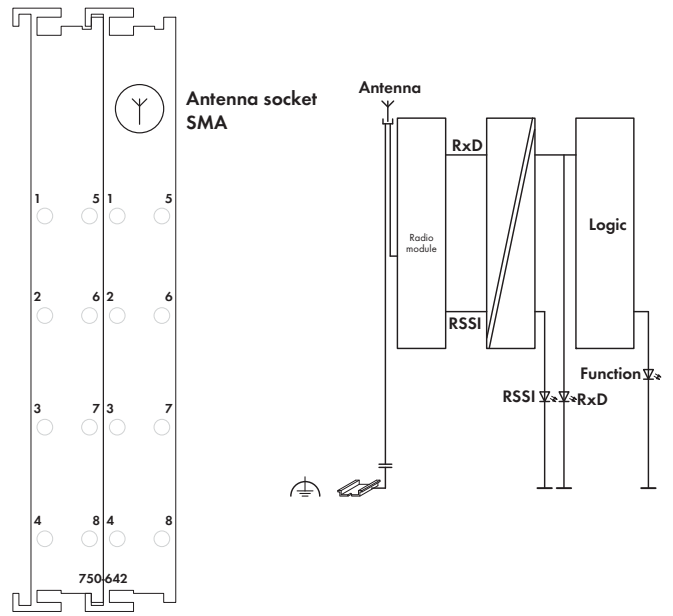

Delivered without miniature WSB markers



The 750-642 I/O Module receives radio telegrams from maintenance-free, battery-less and wireless switches and sensors based on EnOcean radio technology. The module can be used with any controller of the WAGO-I/O-SYSTEM 750. Preprogrammed function blocks make integration easy. The energy required for switch or sensor operation is produced by converting one type of energy (heat, solar or mechanical energy) into usable electrical energy. The radiated energy from the transmitter modules is around one million times smaller than mobile phones. Almost any number of sensors is possible. However, the maximum number is around 100 transmitters per module, due to the increasing density of switches/sensors.

Four billion code numbers provide for clear transmitter/receiver assignment. Repeated, time-shifted transmission of the radio telegrams, at very short transmission times, results in a high level of protection against external interference. The maximum transmission range is approx. 300 meters in open field. Depending on the building materials used and on the spatial geometry, the range may be reduced to typically 30 meters (see manual for more information). The LED (RSSI) indicates a sufficient input level. \*Documentation available in German and English. An SMA socket which is integrated into the housing allows the connection of an external antenna. The 758-910 external antenna has a magnetic stand and a 2.5m long coax cable with SMA plug (available as an accessory).

Description	Item No.	Pack. Unit
Radio Receiver Module	750-642	1
<b>Accessories</b>		
Miniature WSB Quick marking system		
 plain	248-501	5
with marking	see Section 11	
External antenna GSM 900/1800	758-910	1
<b>Approvals</b>		
Conformity marking RTTE	www.wago.com	
Conformity marking	CE	
Korea Certification		
UL 508		
ANSI/ISA 12.12.01	Class I, Div. 2, Grp. ABCD, T4	
TÜV 07 ATEX 554086 X	I M2 Ex d I Mb, II 3 G Ex nA IIC T4 Gc, II 3 D Ex tc IIIC T135°C Dc	
Permissible ambient temperature	0 °C ... +60 °C	
IECEx TUN 09.0001 X	Ex d I Mb, Ex nA IIC T4 Gc, Ex tc IIIC T135°C Dc	
Permissible ambient temperature	0 °C ... +60 °C	

Technical Data	
Frequency band	868.3 MHz
Transmission range	300 m in open field (typ. in buildings see manual)
Transmission protocol (radio telegram)	EnOcean
Current consumption (internal)	80 mA
Power supply	via system voltage DC/DC
Isolation	500 V antenna connection/system
Internal bit width	1 x 24 bits in/out (3 bytes user data)
	1 x 8 bits control/status
Dimensions (mm) W x H x L	24 x 64* x 100
	* + excess length of the SMA socket
	approx. 6.5 mm
Weight	80 g
EMC immunity of interference	acc. to EN 61000-6-2
EMC emission of interference	acc. to EN 61000-6-3

# 4-Channel EnOcean Radio Receivers in DIN-Rail Mount Enclosure

	<b>4-channel EnOcean radio receiver with 4 changeover contacts, 8 A</b>	<b>4-channel EnOcean radio receiver with 4 make contacts, 16 A</b>
--	-----------------------------------------------------------------------------	------------------------------------------------------------------------

The 4-channel radio receiver in DIN-rail mount enclosure is used to switch 4 independent electrical devices or loads. The radio receiver processes telegrams transmitted by sensors (binary information) using EnOcean radio technology (PTM + STM modules). The outputs are switched via relay contacts.



- Radio receiver for battery-less and wireless sensors
- LED indication of switch status
- External antenna for optimum transmission range (required)
- Frequency band 868 MHz
- Transmitter-to-receiver assignment via learn mode

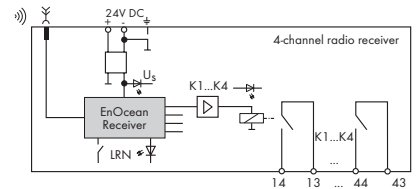
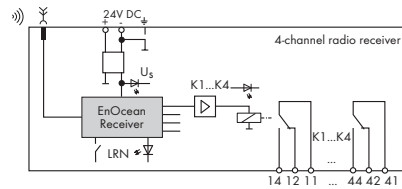

Description	Item No.	Pack. Unit	Item No.	Pack. Unit
4-channel EnOcean radio receiver	789-602	1	789-601	1

### Technical Data

Voltage supply	24 V DC	24 V DC
Voltage range	-15 % ... +20 %	-15 % ... +20 %
Current consumption (internal)	max. 90 mA	max. 90 mA
Number of receive channels	40 (10 per output)	40 (10 per output)
Number of channels	4 (relay outputs)	4 (relay outputs)
Output current (per channel)	max. 8 A, AC1	max. 16 A, AC1
Type of load	resistive / motor load	resistive / lamp load
Switching frequency	max. < 5 Hz	max. < 5 Hz
Delay time transmitter /output command	< 100 ms; 40 ms ... 70 ms typ.	< 100 ms; 40 ms ... 70 ms typ.
Switching voltage	230 VAC	230 VAC
Fuse protection	Loads: wire breaker, max.16 A	Loads: wire breaker, max.16 A
Isolation	potential free contacts	potential free contacts
Ambient operating temperature	0 °C ... +55 °C	0 °C ... +55 °C
Storage temperature	-25 °C ... +85 °C	-25 °C ... +85 °C
Relative air humidity (no condensation)	85%	85%
Degree of pollution	2	2
Degree of protection	IP20	IP20
Mounting position	any	any
Dimensions (mm) W x H x L	70 x 55 x 90	70 x 55 x 90
	Height from upper-edge of DIN 35 rail	Height from upper-edge of DIN 35 rail
Wire connection	CAGE CLAMP®	CAGE CLAMP®
Cross sections	0.08 mm <sup>2</sup> ... 2.5 mm <sup>2</sup> / AWG 28 ... 12 (THHN, THWN)	0.08 mm <sup>2</sup> ... 2.5 mm <sup>2</sup> / AWG 28 ... 12 (THHN, THWN)
Strip lengths	5 ... 6 mm / 0.22 in	5 ... 6 mm / 0.22 in
Standards/specifications	Vibration and shock resistance acc. to IEC 60068-2-6 and IEC 60068-2-27	Vibration and shock resistance acc. to IEC 60068-2-6 and IEC 60068-2-27
Accessories: RF magnetic antenna incl. 3m connecting cable with SMA connector	758-910	758-910

	<b>4-channel radio receiver with 4 make contacts</b>	<b>2-channel radio receiver with sunblind outputs</b>
--	----------------------------------------------------------	-----------------------------------------------------------

The 4-channel radio receiver is used to switch 4 independent electrical devices. The 2-channel radio receiver has 2 sunblind outputs that can be controlled independently from each other. The radio receiver processes telegrams transmitted by switches using EnOcean radio technology (STM modules). The outputs are switched via relay contacts.

- Radio receiver for battery-less and wireless sensors
- LED indication of switch status
- External antenna for optimum transmission range (required)
- Frequency band 868 MHz
- Transmitter-to-receiver assignment via learn mode
- The state of outputs can be predefined for a power failure scenario
- Wire connection using WINSTA connectors

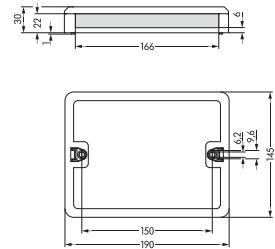
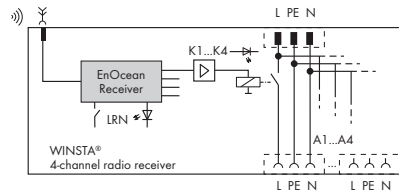

Illustration and block diagram for 770-629/101-000



Description	Item No.	Pack. Unit	Item No.	Pack. Unit
WINSTA® radio receiver	770-629/101-000	1	770-629/102-000	1

**Technical Data**

	770-629/101-000	770-629/102-000
Voltage supply	230 V AC, 50 Hz ... 60 Hz, max. 16 A	230 V AC, 50 Hz ... 60 Hz, max. 16 A
Voltage range	± 10 %	± 10 %
Current consumption (internal)	max. 21 mA	max. 21 mA
Number of channels	4	2
Output current (per channel)	max. 16 A / 4 A	2 A motor load
Total current	max. 16 A	max. 4 A
Inrush current	max. 120 A / 50 ms	25 A
Type of load	resistive / lamp load	resistive / inductive
Switching frequency	max. 5 Hz	max. 5 Hz
Isolation	isolated internal voltage supply 2500 V impulse withstand voltage	isolated internal voltage supply 2500 V impulse withstand voltage
Fuse protection	External, 16 A max.	External, 16 A max.
Ambient operating temperature	0 °C ... +55 °C	0 °C ... +55 °C
Storage temperature	-25 °C ... +85 °C	-25 °C ... +85 °C
Relative air humidity (no condensation)	85%	85%
Degree of pollution	2	2
Degree of protection	IP20	IP20
Mounting position	any	any
Dimensions (mm) W x H x L	190 x 145 x 30	190 x 145 x 30
Type of mounting	Wall screw adapter	Wall screw adapter
Standards/specifications	Vibration and shock resistance acc. to IEC 60068-2-6 and IEC 60068-2-27	Vibration and shock resistance acc. to IEC 60068-2-6 and IEC 60068-2-27
Accessories: RF magnetic antenna incl. 3m connecting cable with SMA connector	758-910	758-910
Connection accessories WINSTA connectors	Input: socket, 3 poles, e.g. 770-103; 4-channel output: plug, 3 poles, e.g. 770-113	Input: socket, 3 poles, e.g. 770-103; 2-channel output: plug, 4 poles, e.g. 770-114



External antenna, GSM 900/1800



External antenna, WLAN/Bluetooth 2.4 GHz



Description	Item No.	Pack. Unit	Technical Data
External antenna	GSM 900/1800	758-910	1
			Frequency band: 870 MHz ... 960 MHz; 1710 MHz ... 1880 MHz
			VSWR: 870 MHz ... 960 MHz < 1.5; 1710 MHz ... 1880 MHz < 1.5
			Gain: 870 MHz ... 960 MHz 0 dB; 1710 MHz ... 1880 MHz 0 dB
			Max. Power: 20 W
			Cable length: 250 cm
			Connector: SMA right angle plug + ferrite bead
External antenna	WLAN/Bluetooth 2.4 GHz	758-912	1
			Frequency band: 2400 MHz ... 2485 MHz
			Gain: 2 dBi
			Cable length: 250 cm
			Connector: SMA right angle plug

Notes on operating the antenna with WAGO EnOcean radio receivers: The antenna is to be mounted on a plate measuring at least 9.8 x 9.8 inches (25 x 25 mm) The distance of interfering sources to the antenna and antenna line must be at least 11.8 inches (30 mm) and the free space between the antenna and the next wall must be at least 13.78 inches (35 mm). The antenna cable should, under no circumstances, be bent sharply, since irreversible damage may result to the antenna (RG 174 bend radius > 0.6 inches/15mm)

Radio transmitter, EnOcean easyfit PTM 250



Description	Item No.	Pack. Unit	Technical Data
2-channel light	758-940/001-000	1	Integrated radio transmitter: EnOcean PTM 200
4-channel light	758-940/003-000	1	Energy harvesting source: electrodynamic energy generator, maintenance free
2-channel roller blind	758-940/002-000	1	Radio technology /range: EnOcean 868 MHz, RPS Type 2; 300 m free field, typ. 30 m within buildings
4-channel roller blind	758-940/004-000	1	Total installation height: 14 mm (frame lies directly against the wall)
			Dimensions of rocker /frame cut-out /central plate: 50 x 50 mm / 55 x 55 mm / 71 x 71 mm
			Color: white

The universal switch insert can be integrated into numerous control programmes by different manufacturers, e.g.: BERKER, GIRA, JUNG and MERTEN. Delivery is without frame. Frames of the desired control programm have been orderen separately.