

**WAGO**<sup>®</sup>

857-167



24V= 2A/240V~



2A/27

**WAGO**<sup>®</sup> 857-71

Solid State-Relay

UIN: 24V DC  
OUT: 24V...240V AC / 1A  
Amb. Temp.: -25...+60°C

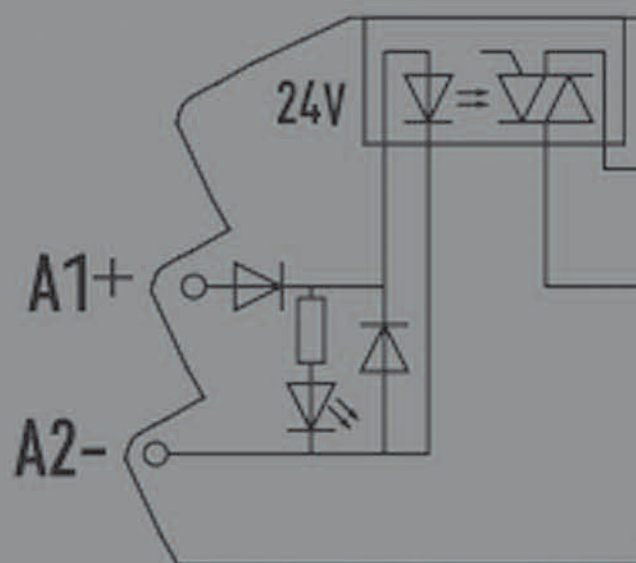
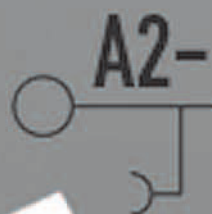
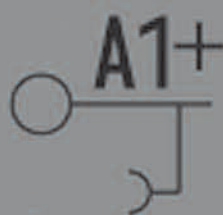

## 2 Relay Sockets with Solid State Relay

118

	<b>Solid state relay</b> <b>Input: 24 V DC</b> <b>Output: 0 V ... 48 V DC / 0.1 A</b>	<b>Solid state relay</b> <b>Input: 115 V AC/DC</b> <b>Output: 0 ... 48 V DC / 0.1 A</b>
--	---	---

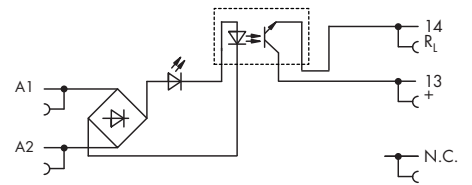
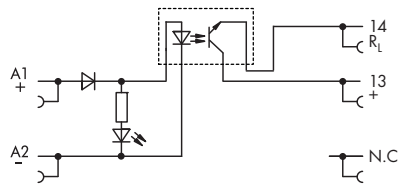
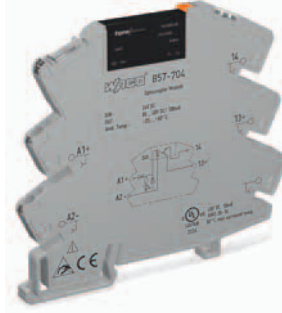
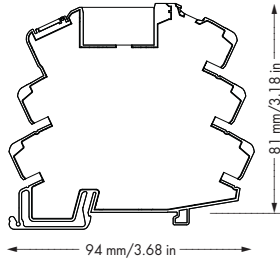

Description	V <sub>N</sub>	I <sub>N</sub>	Item No.	Pack. Unit	V <sub>N</sub>	I <sub>N</sub>	Item No.	Pack. Unit
Relay socket with solid state relay, for DIN 35 rail	24VDC	9 mA	857-704	1	115V AC/DC	4.2 mA	857-707	1

Technical Data	Accessories see pages 128 ... 130				Accessories see pages 128 ... 130			
<b>Control circuit:</b>								
Input voltage range (low level)		0 V ... 10 V DC				0 V ... 25 V AC/DC		
Input voltage range (high level)		18 V ... 28.8 V DC				100 V ... 138 V AC/DC		
<b>Load circuit:</b>								
Output voltage range		0 V ... 48 V DC				0 V ... 48 V DC		
Max. continuous current		0.1 ADC				0.1 ADC		
Max. voltage drop at output		< 1VDC				< 1VDC		
Reverse voltage transistor/triac		54 V				54 V		
<b>General specifications:</b>								
Dielectric strength, control/load circuit (AC, 1 min)		2.5 kV <sub>rms</sub>				2.5 kV <sub>rms</sub>		
Ambient operating temperature		-20 °C ... +60 °C				-20 °C ... +60 °C		
Storage temperature		-40 °C ... +70 °C				-40 °C ... +70 °C		
Dimensions (mm) W x H x L		6 x 81 x 94				6 x 81 x 94		
Wire connection		Height from upper-edge of DIN 35 rail CAGE CLAMP® S				Height from upper-edge of DIN 35 rail CAGE CLAMP® S		
Cross sections		0.34 mm <sup>2</sup> ... 2.5 mm <sup>2</sup> / AWG 22 ... 12				0.34 mm <sup>2</sup> ... 2.5 mm <sup>2</sup> / AWG 22 ... 12		
Strip length		9 ... 10 mm / 0.37 in				9 ... 10 mm / 0.37 in		
Standards/specifications		EN 61000-6-2; EN 61000-6-4				EN 61000-6-2; EN 61000-6-4		
Approvals		CE; UL 508				CE; UL 508		

**Solid state relay**  
**Input: 230 V AC/DC**  
**Output: 0 V ... 48 V DC / 0.1 A**

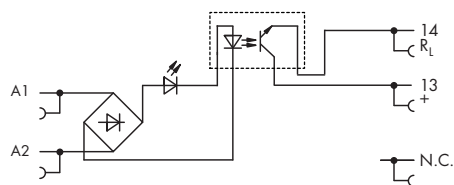
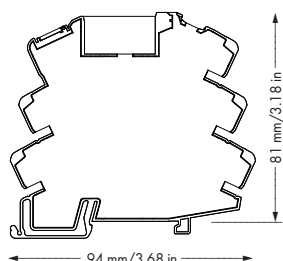

Description	V <sub>N</sub>	I <sub>N</sub>	Item No.	Pack. Unit
Relay socket with solid state relay, for DIN 35 rail	230V AC/DC	3.25 mA	857-708	1

**Technical Data**

Accessories see pages 128 ... 130

<b>Control circuit:</b>	
Input voltage range (low level)	0 V ... 30 V AC/DC
Input voltage range (high level)	200 V ... 253 V AC/DC
<b>Load circuit:</b>	
Output voltage range	0 V ... 48 V DC
Max. continuous current	0.1 ADC
Max. voltage drop at output	< 1VDC
Reverse voltage transistor/triac	54 V
<b>General specifications:</b>	
Dielectric strength, control/load circuit (AC, 1 min)	2.5 kV <sub>rms</sub>
Ambient operating temperature	-20 °C ... +60 °C
Storage temperature	-40 °C ... +70 °C
Dimensions (mm) W x H x L	6 x 81 x 94
Wire connection	Height from upper-edge of DIN 35 rail
Cross sections	CAGE CLAMP® S
Strip length	0.34 mm <sup>2</sup> ... 2.5 mm <sup>2</sup> / AWG 22 ... 12
Standards/specifications	9 ... 10 mm / 0.37 in
Approvals	EN 61000-6-2; EN 61000-6-4
	CE; UL 508

# 2 Relay Sockets with Solid State Relay

	<b>Solid state relay</b> Input: 24 V DC Output: 24 V ... 240 V AC / 2 A	<b>Solid state relay</b> Input: 115 V AC/DC Output: 24 V ... 240 V AC / 2 A
--	---	---

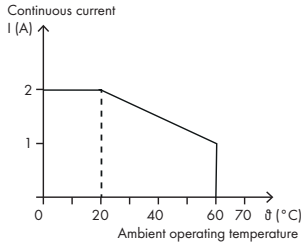

Derating

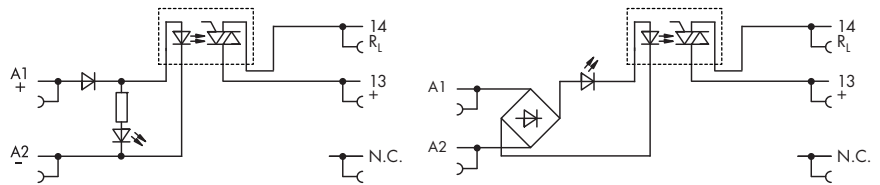
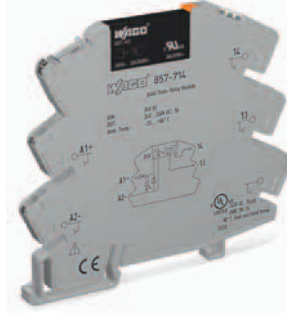

Description	V <sub>N</sub>	I <sub>N</sub>	Item No.	Pack. Unit	V <sub>N</sub>	I <sub>N</sub>	Item No.	Pack. Unit
Relay socket with solid state relay, for DIN 35 rail	24VDC	9.2 mA	857-714	1	115V AC/DC	3.9 mA	857-717	1

Technical Data	Accessories see pages 128 ... 130				Accessories see pages 128 ... 130			
<b>Control circuit:</b>								
Input voltage range (low level)		0 V ... 10 V DC				0 V ... 25 V AC/DC		
Input voltage range (high level)		20 V ... 28.8 V DC				90 V ... 138 V		
<b>Load circuit:</b>								
Output voltage range		24 ... 240 V AC				24 ... 240 V AC		
Max. continuous current		2 A AC				2 A AC		
Max. voltage drop at output		< 1 V AC				< 1 V AC		
Reverse voltage transistor/triac		600 V				600 V		
<b>General specifications:</b>								
Dielectric strength, control/load circuit (AC, 1 min)		2.5 kV <sub>rms</sub>				2.5 kV <sub>rms</sub>		
Ambient operating temperature		-20 °C ... +60 °C				-20 °C ... +60 °C		
Storage temperature		-40 °C ... +70 °C				-40 °C ... +70 °C		
Dimensions (mm) W x H x L		6 x 81 x 94				6 x 81 x 94		
Wire connection		Height from upper-edge of DIN 35 rail CAGE CLAMP® S				Height from upper-edge of DIN 35 rail CAGE CLAMP® S		
Cross sections		0.34 mm <sup>2</sup> ... 2.5 mm <sup>2</sup> / AWG 22 ... 12				0.34 mm <sup>2</sup> ... 2.5 mm <sup>2</sup> / AWG 22 ... 12		
Strip length		9 ... 10 mm / 0.37 in				9 ... 10 mm / 0.37 in		
Standards/specifications		EN 61000-6-2; EN 61000-6-4				EN 61000-6-2; EN 61000-6-4		
Approvals		CE; UL 508				CE; UL 508		

Solid state relay  
 Input: 230 V AC/DC  
 Output: 24 V ... 240 V AC / 2 A

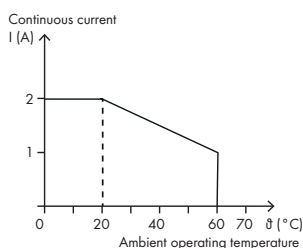

Derating

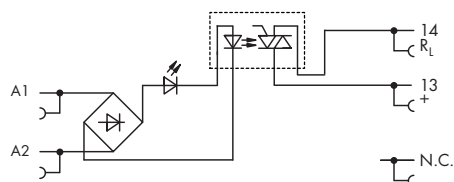

Description	V <sub>N</sub>	I <sub>N</sub>	Item No.	Pack. Unit
Relay socket with solid state relay, for DIN 35 rail	230V AC/DC	3.2 mA	857-718	1

**Technical Data**

Accessories see pages 128 ... 130

<b>Control circuit:</b>		
Input voltage range (low level)	0 V ... 60 V AC/DC	
Input voltage range (high level)	200 V ... 253 V AC/DC	
<b>Load circuit:</b>		
Output voltage range	24 ... 240 V AC	
Max. continuous current	2 A AC	
Max. voltage drop at output	< 1 V AC	
Reverse voltage transistor/triac	600 V	
<b>General specifications:</b>		
Dielectric strength, control/load circuit (AC, 1 min)	2.5 kV <sub>rms</sub>	
Ambient operating temperature	-20 °C ... +60 °C	
Storage temperature	-40 °C ... +70 °C	
Dimensions (mm) W x H x L	6 x 81 x 94	
Wire connection	Height from upper-edge of DIN 35 rail CAGE CLAMP® S	
Cross sections	0.34 mm <sup>2</sup> ... 2.5 mm <sup>2</sup> / AWG 22 ... 12	
Strip length	9 ... 10 mm / 0.37 in	
Standards/specifications	EN 61000-6-2; EN 61000-6-4	
Approvals	CE; UL 508	



**Solid state relay**  
**Input: 230 V AC/DC**  
**Output: 0 V ... 24 V DC / 3 A**

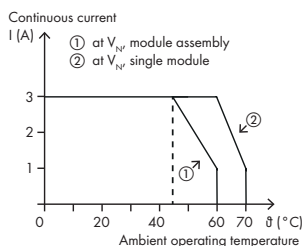

Derating

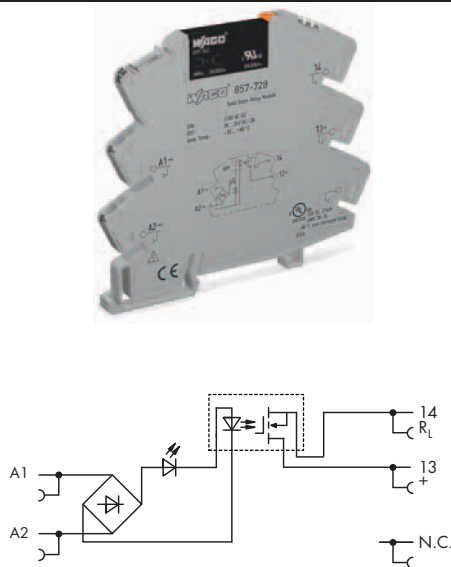

Description	$V_N$	$I_N$	Item No.	Pack. Unit
<b>Relay socket with solid state relay, for DIN 35 rail</b>	230V AC/DC	3.2 mA	<b>857-728</b>	1

### Technical Data

Accessories see pages 128 ... 130

<b>Control circuit:</b>	
Input voltage range (low level)	0 V ... 60 V AC/DC
Input voltage range (high level)	200 V ... 253 V AC/DC
<b>Load circuit:</b>	
Output voltage range	0 V ... 24 V DC
Max. continuous current	3 ADC
Max. voltage drop at output	< 120mV DC
Reverse voltage transistor/triac	33 V
<b>General specifications:</b>	
Dielectric strength, control/load circuit (AC, 1 min)	2.5 kV <sub>rms</sub>
Ambient operating temperature	-20 °C ... +70 °C
Storage temperature	-40 °C ... +70 °C
Dimensions (mm) W x H x L	6 x 81 x 94
Wire connection	Height from upper-edge of DIN 35 rail CAGE CLAMP® S
Cross sections	0.34 mm <sup>2</sup> ... 2.5 mm <sup>2</sup> / AWG 22 ... 12
Strip length	9 ... 10 mm / 0.37 in
Standards/specifications	EN 61000-6-2; EN 61000-6-4
Approvals	CE; UL 508

	<b>Dual channel optocoupler</b> <b>Input: 24 VDC</b> <b>Output: 9 – 60 VDC / 0.1 A</b>	<b>Dual channel optocoupler</b> <b>Input: 24 VDC</b> <b>Output: 3 – 31.2 VDC / 3 A</b>
--	--	--

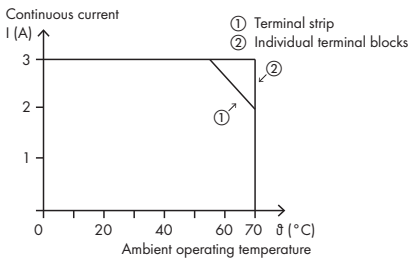

Derating for 857-1430

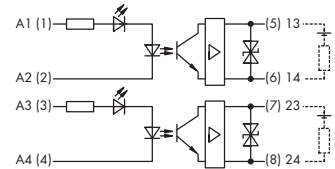
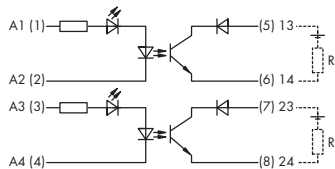
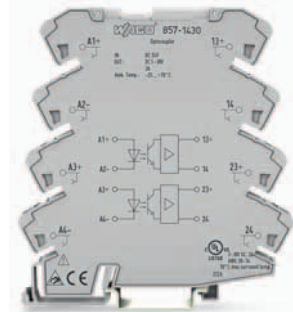
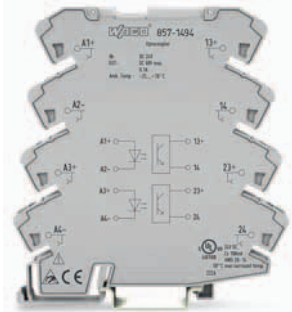

Description	V <sub>N</sub>	I <sub>N</sub>	Item No.	Pack. Unit	V <sub>N</sub>	I <sub>N</sub>	Item No.	Pack. Unit
Optocoupler module, for DIN 35 rail	24 VDC	5.6 mA	857-1494	1	24 VDC	7.75	857-1430	1

Technical Data	Accessories see pages 128 ... 130				Accessories see pages 128 ... 130			
<b>Control circuit:</b>								
Input voltage range (low level)	0-5 VDC				0-5 VDC			
Input voltage range (high level)	16.8 ... 31.2 VDC				16.8 ... 31.2 VDC			
<b>Load circuit:</b>								
Output voltage range	9-60 VDC				3-31.2 VDC			
Max. continuous current	0.1 ADC				3 ADC			
Turn-on time	20 μs				25 μs			
Turn-off time	120 μs				250 μs			
Max. switching frequency	1.5 kHz				300Hz			
Max. voltage drop at output	2 V				0.2 V			
Reverse voltage transistor/triac	100 V				55 V			
<b>General specifications:</b>								
Dielectric strength, control/load circuit (AC, 1 min)	2.5 kV <sub>rms</sub>				2.5 kV <sub>rms</sub>			
Dielectric strength, channel/channel (AC, 1 min)	4 kV <sub>rms</sub>				4 kV <sub>rms</sub>			
Ambient operating temperature	-20 °C ... +70 °C				-20 °C ... +70 °C			
Storage temperature	-40 °C ... +85 °C				-40 °C ... +85 °C			
Dimensions (mm) W x H x L	6 x 96 x 94				6 x 96 x 94			
Wire connection	Height from upper-edge of DIN 35 rail CAGE CLAMP® S				Height from upper-edge of DIN 35 rail CAGE CLAMP® S			
Cross sections	0.08 mm <sup>2</sup> ... 2.5 mm <sup>2</sup> / AWG 28 ... 12				0.08 mm <sup>2</sup> ... 2.5 mm <sup>2</sup> / AWG 28 ... 14			
Strip length	9 ... 10 mm / 0.35 ... 0.39 in				9 ... 10 mm / 0.35 ... 0.39 in			
Standards/specifications	EN 60664-1; EN 60947-5; EN 61000-6-2; EN 61000-6-4				EN 60664-1; EN 60947-5; EN 61000-6-2; EN 61000-6-4			
Approvals	UL 508 (max. 50 °C/100 mA)				CE; g; UL 508 (max. 70 °C/2 A)			



**Dual channel optocoupler**  
**Input: 24 VDC**  
**Output: 2 changeover contacts, 3 ... 30 VDC / 0.5 A**

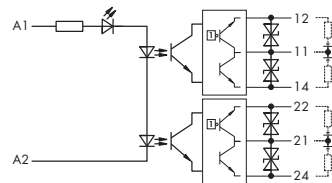
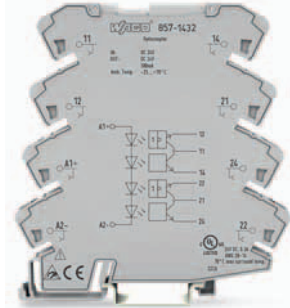
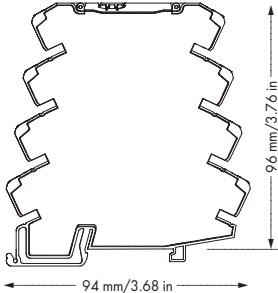

Description	$V_N$	$I_N$	Item No.	Pack. Unit	
Optocoupler module, for DIN 35 rail	24 V DC	5.9 mA	857-1432	1	

Technical Data		Accessories see pages 128 ... 130	
<b>Control circuit:</b>			
Input voltage range (low level)		0 V ... 5 V DC	
Input voltage range (high level)		16.8 V ... 30 V DC	
<b>Load circuit:</b>			
Output voltage range		2 x 9 V ... 60 VDC	
Max. continuous current		2 x 500 mA	
Turn-on time		25 $\mu$ s	
Turn-off time		250 $\mu$ s	
Max. switching frequency		1.5 kHz	
Max. voltage drop at output		1.5 V	
<b>General specifications:</b>			
Dielectric strength, control/load circuit (AC, 1 min)		3.75 kV <sub>rms</sub>	
Dielectric strength, channel/channel (AC, 1 min)		-	
Ambient operating temperature		-20 °C ... +70 °C	
Storage temperature		-40 °C ... +85 °C	
Dimensions (mm) W x H x L		6 x 96 x 94	
Wire connection		Height from upper-edge of DIN 35 rail CAGE CLAMP® S	
Cross sections		0.08 mm <sup>2</sup> ... 2.5 mm <sup>2</sup> / AWG 28 ... 12	
Strip length		9 ... 10 mm / 0.35 ... 0.39 in	
Standards/specifications		EN 60664-1	

## Multifunction Time Relays with Solid State Relay

Multifunction time relay with plugged SSR  
 1 make contact (1a)  
 4 time ranges, 4 functions  
 Switching voltage: 0 ... 24 VDC

- 4 functions:
  - On-delay
  - Single-shot leading edge
  - On-delay and single-shot leading edge (1 s fixed)
  - Blinking
- Function and time range adjustable via DIP switch

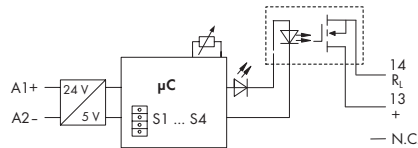

Description	V <sub>N</sub>	I <sub>N</sub>	Item No.	Pack. Unit
Multifunction time relay, for DIN 35 rail	24 VDC	9.15 mA	857-624	1

Technical Data		Accessories see pages 128 ... 130	
<b>Control circuit:</b>			
Input voltage range	V <sub>N</sub> -15 % ... +30 %		
Power consumption at V <sub>N</sub>	9.15 mA (active) / 2.5 mA (passive)		
<b>Load circuit:</b>			
Switching voltage	0 V ... 24 V DC		
Peak reverse voltage	33 V		
Max. switching current	2 A		
Turn-on time	100 µs		
Turn-off time	2 ms		
Forward voltage at max. switching current	< 120mV DC		
<b>General specifications:</b>			
Time range	adjustable: 0.1 ... 10 s; 3 ... 300 s; 0.3 ... 30 min; 3 ... 300 min		
Reset time	50 ms		
Repeat accuracy	±1 %		
Dielectric strength, control/load circuit (AC, 1 min)	2.5 kV <sub>rms</sub>		
Ambient operating temperature	-20 °C ... +60 °C		
Storage temperature	-40 °C ... +70 °C		
Dimensions (mm) W x H x L	6 x 81 x 94		
Wire connection	Height from upper-edge of DIN 35 rail CAGE CLAMP® S		
Cross sections	0.34 mm <sup>2</sup> ... 2.5 mm <sup>2</sup> / AWG 22 ... 14		
Strip length	9 ... 10 mm / 0.35 ... 0.39 in		
Standards/specifications	EN 60664-1; EN 61812-1; EN 61373; EN50121-3-2		
Approvals	CE		

	<b>Multifunction time relay with plugged SSR</b> <b>1 make contact (1 a)</b> <b>4 time ranges, 4 functions</b> <b>Switching voltage: 24 ... 230 VAC</b>	
--	--	--

- 4 functions:
  - On-delay
  - Single-shot leading edge
  - On-delay and single-shot leading edge (1 s fixed)
  - Blinking
- Function and time range adjustable via DIP switch

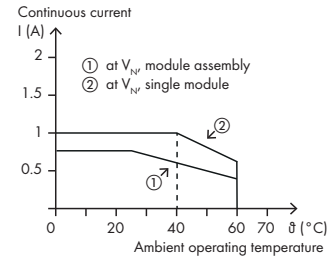

Derating

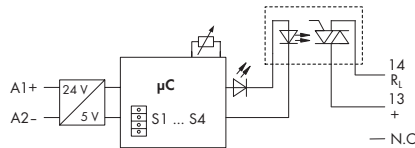

Description	V <sub>N</sub>	I <sub>N</sub>	Item No.	Pack. Unit
Multifunction time relay, for DIN 35 rail	24 VDC	9.15 mA	857-634	1

**Technical Data**

Accessories see pages 128 ... 130

<b>Control circuit:</b>	
Input voltage range	V <sub>N</sub> -15 % ... +30 %
Power consumption at V <sub>N</sub>	9.15 mA (active) / 2.5 mA (passive)
<b>Load circuit:</b>	
Switching voltage	24 V ... 230 V AC
Peak reverse voltage	600 V
Max. switching current	1 A
Turn-on time	1 ms
Turn-off time	10 ms
Forward voltage at max. switching current	< 1 VAC
<b>General specifications:</b>	
Time range	adjustable: 0.1 ... 10 s; 3 ... 300 s; 0.3 ... 30 min; 3 ... 300 min
Reset time	50 ms
Repeat accuracy	±1 %
Dielectric strength, control/load circuit (AC, 1 min)	2.5 kV <sub>rms</sub>
Ambient operating temperature	-20 °C ... +60 °C
Storage temperature	-40 °C ... +70 °C
Dimensions (mm) W x H x L	6 x 81 x 94
Wire connection	Height from upper-edge of DIN 35 rail CAGE CLAMP® S
Cross sections	0.34 mm <sup>2</sup> ... 2.5 mm <sup>2</sup> / AWG 22 ... 14
Strip length	9 ... 10 mm / 0.35 ... 0.39 in
Standards/specifications	EN 60664-1; EN 61812-1; EN 61373; EN50121-3-2
Approvals	CE

	Pluggable replacement solid state relay	Pluggable replacement solid state relay
--	---	---



Description	Item No.	Pack. Unit	Item No.	Pack. Unit	Item No.	Pack. Unit
Pluggable replacement solid state relay	857-161	20	857-164	20	857-167	20

Technical Data						
<b>Control circuit:</b>						
Nominal input voltage (V <sub>N</sub> )	24 V DC		24 V DC		24 V DC	
Input voltage range	18 V ... 30 V DC		16 V ... 30 V DC		18 V ... 30 V DC	
Nominal input current (I <sub>N</sub> )	7 mA		7 mA		7 mA	
<b>Load circuit:</b>						
Switching voltage	0 V ... 24 V DC		0 V ... 48 V DC		24 V ... 240 V AC	
Peak reverse voltage	33 V		54 V		600 V	
Max. switching current	3 A DC		100 mA DC		2 A AC	
Forward voltage at max. switching current	< 120 mV DC		< 1 V DC		< 1 V AC	
Dielectric strength control/switching circuit	2.5 kV		2.5 kV		2.5 kV	
<b>General Specifications</b>						
Ambient operating temperature	-30 °C ... +80 °C		-20 °C ... +60 °C		-30 °C ... +80 °C	
Storage temperature	-40 °C ... +100 °C		-40 °C ... +70 °C		-40 °C ... +100 °C	
Dimensions (mm) W x H x L	5 x 15 x 28		5 x 15 x 28		5 x 15 x 28	

Description	Item No.	Pack. Unit	Item No.	Pack. Unit	Item No.	Pack. Unit
Pluggable replacement solid state relay	857-162	20	857-165	20	857-168	20

Technical Data						
<b>Control circuit:</b>						
Nominal input voltage (V <sub>N</sub> )	60 V DC		60 V DC		60 V DC	
Input voltage range	35 V ... 72 V DC		52 V ... 72 V DC		35 V ... 72 V DC	
Nominal input current (I <sub>N</sub> )	3 mA		2.8 mA		3.1 mA	
<b>Load circuit:</b>						
Switching voltage	0 V ... 24 V DC		0 V ... 48 V DC		24 V ... 240 V AC	
Peak reverse voltage	33 V		54 V		600 V	
Max. switching current	3 A DC		100 mA DC		2 A AC	
Forward voltage at max. switching current	< 120 mV DC		< 1 V DC		< 1 V AC	
Dielectric strength control/switching circuit	2.5 kV		2.5 kV		2.5 kV	
<b>General Specifications</b>						
Ambient operating temperature	-30 °C ... +80 °C		-20 °C ... +60 °C		-20 °C ... +80 °C	
Storage temperature	-40 °C ... +100 °C		-40 °C ... +70 °C		-40 °C ... +100 °C	
Dimensions (mm) W x H x L	5 x 15 x 28		5 x 15 x 28		5 x 15 x 28	

	<b>Sockets for miniature switching relay and SSR</b>	
--	--	--

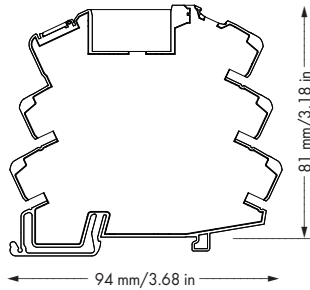

Description	Item No.	Pack. Unit
Socket for miniature switching relay and SSR, 24 V AC/DC for DIN 35 rail	857-104	1
Socket for miniature switching relay and SSR, 110 V AC/DC for DIN 35 rail	857-107	1
Socket for miniature switching relay and SSR, 230 V AC/DC for DIN 35 rail	857-108	1

**Technical Data**

Status indication	LED yellow
Operating temperature	-25 °C ... +70 °C
Storage temperature	-40 °C ... +70 °C
Dimensions (mm) W x H x L	6 x 81 x 94
Wire connection	Height from upper-edge of DIN 35 rail CAGE CLAMP® S
Cross sections	0.34 mm <sup>2</sup> ... 2.5 mm <sup>2</sup> / AWG 22 ... 12
Strip length	9 ... 10 mm / 0.37 in
Approvals	UL

**Assignment Socket / Replacement Relay / Replacement Optocoupler**

	Input Voltage	Item No.	Socket	Replacement Relays or Optocouplers
Miniature Switching Relays	12 V DC	857-303	857-103	857-150
	24 V DC	857-304	857-104	857-152
	48 V DC	857-305	857-105	857-154
	60 V DC	857-306	857-106	857-155
	110 V DC	857-307	857-107	857-155
	220 V DC	857-308	857-108	857-155
	24 V AC/DC	857-354	857-104	857-152
	115 V AC/DC	857-357	857-107	857-155
	230 V AC/DC	857-358	857-108	857-155
Miniature Switching Relays (gold contacts)	24 V DC	857-314	857-104	857-153
	110 V DC	857-317	857-107	857-157
	220 V DC	857-318	857-108	857-157
	24 V AC/DC	857-364	857-104	857-153
	115 V AC/DC	857-367	857-107	857-157
	230 V AC/DC	857-368	857-108	857-157
Solid State Relays	24 V DC	857-704	857-104	857-164
	115 V AC/DC	857-707	857-107	857-165
	230 V AC/DC	857-708	857-108	857-165
	24 V DC	857-714	857-104	857-167
	115 V AC/DC	857-717	857-107	857-168
	230 V AC/DC	857-718	857-108	857-168
	24 V DC	857-724	857-104	857-161
	115 V AC/DC	857-727	857-107	857-162
230 V AC/DC	857-728	857-108	857-162	

## 2 Accessories, 857 Series

130

Push-in type jumper bar



Commoning



Description		Item No.	Pack. Unit
Push-in type jumper bars, light gray, insulated, 18 A	2-way	859-402	200 (8x25)
	3-way	859-403	200 (8x25)
	4-way	859-404	200 (8x25)
	5-way	859-405	200 (8x25)
	6-way	859-406	100 (4x25)
	7-way	859-407	100 (4x25)
	8-way	859-408	100 (4x25)
	9-way	859-409	100 (4x25)
	10-way	859-410	100 (4x25)
	Item no. suffix for colored push-in type jumper bars	yellow	... /000-029
red		... /000-005	
blue		... /000-006	
Comb-style jumper bar, insulated	2-way	281-482	100

WMB Multi marking system



Marking



Description		Item No.	Pack. Unit
WMB Multi marking system	plain	793-501	5 cards
Marking software and printer/plotter see Section 11			
Marking	1 ... 10 (10x)	793-502	5 cards
	11 ... 20 (10x)	793-503	5 cards
	21 ... 30 (10x)	793-504	5 cards
	31 ... 40 (10x)	793-505	5 cards
	41 ... 50 (10x)	793-506	5 cards
	1 ... 50 (2x)	793-566	5 cards
10 strips with 10 markers, white with black printing			

Operating tool



Description		Item No.	Pack. Unit
Operating tool, with partially insulated shaft	Type 2, blade (3.5 x 0.5) mm	210-720	1



## 2 Relay Sockets with Solid State Relay

132

	<b>Solid state relay</b> <b>Input: 24 V DC</b> <b>Output: 0 V ... 24 V DC / 3.5 A</b>	<b>Solid state relay</b> <b>Input: 24 V DC</b> <b>Output: 0 V ... 24 V DC / 5 A</b>
--	---	---

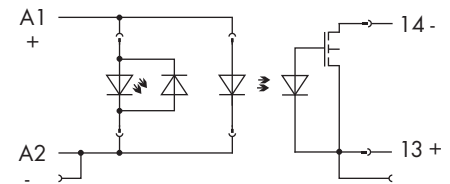
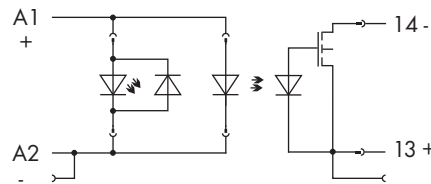
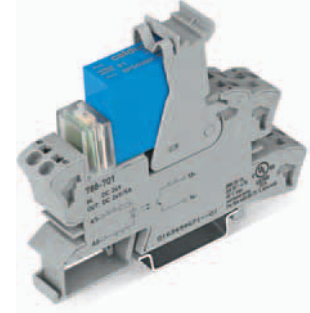
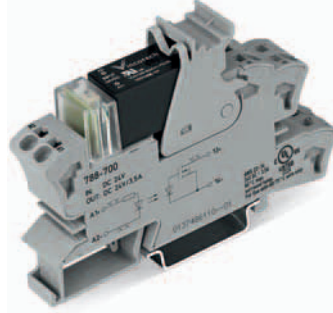

Description	V <sub>N</sub>	I <sub>N</sub>	Item No.	Pack. Unit	V <sub>N</sub>	I <sub>N</sub>	Item No.	Pack. Unit
Relay socket with solid state relay, for DIN 35 rail	24 V DC	7 mA	788-700	1	24 V DC	9.3 mA	788-701	1

Technical Data		Accessories see pages 134 ... 136		Accessories see pages 134 ... 136	
<b>Control circuit:</b>					
Input voltage range (low level)		0V...8 V DC		0 V ... 2.5 V DC	
Input voltage range (high level)		18 V ... 30 V DC		15 V ... 30 V DC	
<b>Load circuit:</b>					
Output voltage range		0 ... 24 V DC		0 V ... 30 V DC	
Max. continuous current		3.5 ADC		5 ADC	
Turn-on time		50 μs		50 μs	
Turn-off time		600 μs		600 μs	
Max. switching frequency				100 Hz at 5 A	
Max. voltage drop at output		< 0.1 VDC		0.3 V DC	
Reverse voltage transistor/triac		33 V		36 V	
<b>General specifications:</b>					
Nominal voltage to EN 60664-1		250 V / 2.5 kV / 2		250 V / 2.5 kV / 2	
Dielectric strength, control/load circuit (AC, 1 min)		2.5 kV <sub>rms</sub>		2.5 kV <sub>rms</sub>	
Ambient operating temperature		-20 °C ... +60 °C		-40 °C ... +60 °C	
Storage temperature		-40 °C ... +70 °C		-40 °C ... +70 °C	
Dimensions (mm) W x H x L		15 x 53 x 86		15 x 63 x 86	
Wire connection		Height from upper-edge of DIN 35 rail CAGE CLAMP® S		Height from upper-edge of DIN 35 rail CAGE CLAMP® S	
Cross sections		0.34 mm <sup>2</sup> ... 2.5 mm <sup>2</sup> / AWG 22 ... 12		0.34 mm <sup>2</sup> ... 2.5 mm <sup>2</sup> / AWG 22 ... 12	
Strip length		9 ... 10 mm / 0.35 ... 0.39 in		9 ... 10 mm / 0.35 ... 0.39 in	
Standards/specifications		EN 61140; EN 50178, UL 508 (max. 60 °C/3.5 A)		EN 61140; EN 50178, UL 508 (max. 40 °C/4.7 A)	



	<b>Solid state relay</b> <b>Input: 24 V DC</b> <b>Output: 24 V ... 240 V AC / 1 A</b> <b>Zero voltage switch</b>	<b>Solid state relay</b> <b>Input: 24 V AC/DC</b> <b>Output: 12 – 275 VAC / 4 A</b> <b>Zero voltage switch</b>
--	---	---

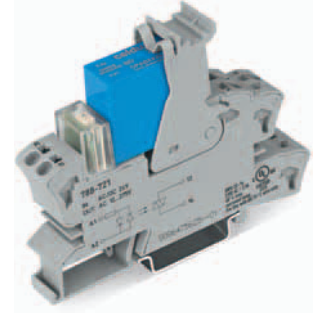
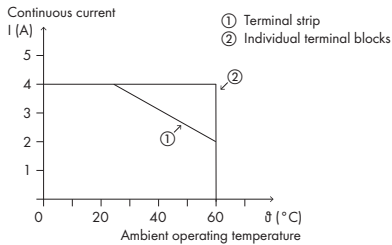

Derating 788-721

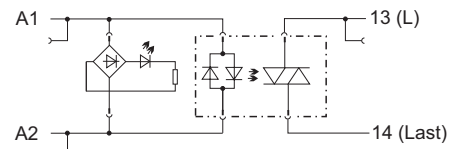
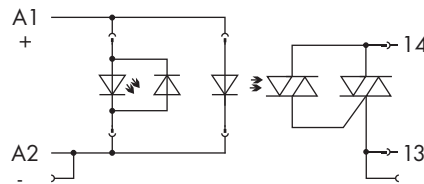

Description	V <sub>N</sub>	I <sub>N</sub>	Item No.	Pack. Unit	V <sub>N</sub>	I <sub>N</sub>	Item No.	Pack. Unit
Relay socket with solid state relay, for DIN 35 rail	24 V DC	7 mA	788-720	1	24 V AC/DC	10 mA	788-721	

**Technical Data**

Accessories see pages 134 ... 136

Accessories see pages 134 ... 136

Control circuit:		
Input voltage range (low level)	0V...4 VDC	0V...2.5 V AC/DC
Input voltage range (high level)	18 V ... 30 V DC	15 V ... 30 V AC/DC
<b>Load circuit:</b>		
Output voltage range	24 ... 240 V AC	12 V ... 275 VAC (50/60 Hz)
Max. continuous current	1 A AC	4 A AC
Turn-on time	10 ms	10 ms
Turn-off time	10 ms	10 ms
Max. voltage drop at output	< 1.1 VAC	< 1.1 VAC
Reverse voltage transistor/triac	600 V	600 V
<b>General specifications:</b>		
Nominal voltage to EN 60664-1	250 V / 2.5 kV / 2	250 V / 2.5 kV / 2
Dielectric strength, control/load circuit (AC, 1 min)	3.75 kV <sub>rms</sub>	4 kV <sub>rms</sub>
Ambient operating temperature	-20 °C ... +60 °C	-20 °C ... +60 °C
Storage temperature	-40 °C ... +70 °C	-40 °C ... +70 °C
Dimensions (mm) W x H x L	15 x 53 x 86	15 x 53 x 86
Wire connection	Height from upper-edge of DIN 35 rail CAGE CLAMP® S	Height from upper-edge of DIN 35 rail CAGE CLAMP® S
Cross sections	0.34 mm <sup>2</sup> ... 2.5 mm <sup>2</sup> / AWG 22 ... 12	0.34 mm <sup>2</sup> ... 2.5 mm <sup>2</sup> / AWG 22 ... 12
Strip length	9 ... 10 mm / 0.35 ... 0.39 in	9 ... 10 mm / 0.35 ... 0.39 in
Standards/specifications	EN 61140; EN 50178, UL 508 (max. 60 °C/1 A)	EN 61140; EN 50178, UL 508 (max. 40 °C/2.5 A)

	<b>Sockets for miniature switching relay</b> <b>1 changeover contact / 2 changeover contact</b>	
--	--	--

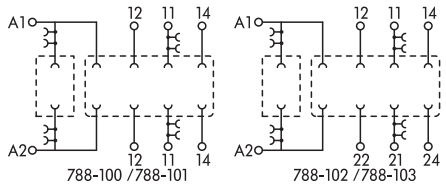
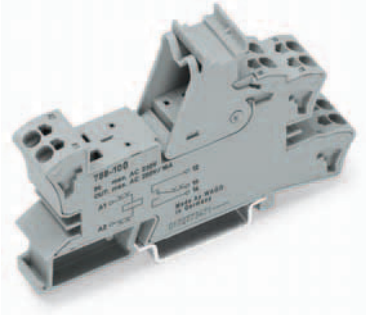
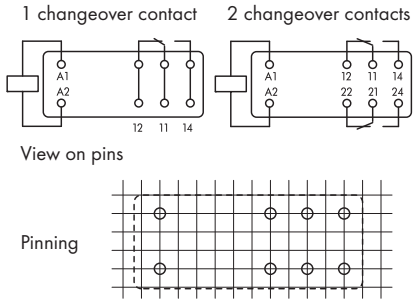

Description	Item No.	Pack. Unit
<b>Socket without relay, for DIN 35 rail</b>		
Relay height 15 mm, 1 changeover contact	<b>788-100</b>	1
Relay height 15 mm, 2 changeover contacts	<b>788-102</b>	1
Relay height 25 mm, 1 changeover contact	<b>788-101</b>	1
Relay height 25 mm, 2 changeover contacts	<b>788-103</b>	1

Technical Data		
<b>Contacts:</b>		
Max. continuous current	16 A / 2 x 8 A	
Max. switching voltage	250 V AC	
Max. switching power (resistive)	4 kVA / 2 x 2 kVA AC	
<b>General specifications:</b>		
Nominal input voltage (V <sub>N</sub> )	depending on relay; max. 250 V AC	
Nominal voltage to EN 60664-1	250 V / 4 kV / 3	
Dielectric strength	5 kV <sub>eff</sub> (depending on relay)	
Storage temperature	-40 °C ... +80 °C	
Ambient operating temperature	-25 °C ... +70 °C (depending on relay)	
Wire connection	CAGE CLAMP® S	
Cross sections	CAGE CLAMP® S	
Strip length	9 ... 10 mm / 0.35 ... 0.39 in	
Standards/specifications	EN 61140; EN 50178	

## Status indication



Description	Power consumption at $V_N$	Item No.	Pack. Unit
Status indication with recovery diode, 24 V DC (12 V ... 24 V)	2.4 mA	788-120	50 (2x25)
Status indication with recovery diode, 48 V DC (48 V ... 60 V)	1.9 mA	788-121	50 (2x25)
Status indication 110 V DC	1.9 mA	788-122	50 (2x25)
Status indication 24 V AC	2.1 mA	788-123	50 (2x25)
Status indication 115 V AC	1.7 mA	788-124	50 (2x25)
Status indication 230 V AC	1.6 mA	788-125	50 (2x25)

Push-in type jumper bar  
788-113

## Commoning



## Push-in type jumper bar



Description			Item No.	Pack. Unit
Push-in type jumper bar, I max. 18 A	2-way	(module/module)	788-113	200 (8x25)
	3-way		788-114	100 (4x25)
	4-way		788-115	100 (4x25)
	6-way		788-116	100 (4x25)
	8-way		788-117	100 (4x25)
Push-in type jumper bars, light gray, insulated, 18 A	2-way	(internal)	859-402	200 (8x25)

## WMB Multi marking system



## Marking



## Group marker carrier



Description		Item No.	Pack. Unit
WMB Multi marking system	plain	793-501	5 cards
Marking software and printer/plotter see Section 11			
Marking	1 ... 10 (10x)	793-502	5 cards
	11 ... 20 (10x)	793-503	5 cards
	21 ... 30 (10x)	793-504	5 cards
	31 ... 40 (10x)	793-505	5 cards
	41 ... 50 (10x)	793-506	5 cards
	1 ... 50 (2x)	793-566	5 cards
10 strips with 10 markers, white with black printing			
Group marker carrier		209-145	100 (50)

## 2 Accessories, 788 Series

136

### Operating tool



Description		Item No.	Pack. Unit
Operating tool, with partially insulated shaft	Type 2, blade (3.5 x 0.5) mm	210-720	1

### Ferrule



Description	Sleeve for mm <sup>2</sup> / AWG	Item No.	Pack. Unit
Ferrule, red insulated, 12 mm	2 x 1 mm <sup>2</sup> / 2 x 18	216-542	500





	<p><b>Optocoupler</b>                  Input: 24 V DC                  Output: 24 V DC/100 mA                  with an extended input voltage and operating temperature range                  for railway applications</p>	<p><b>Optocoupler</b>                  Input: 5 V DC                  Output: 24 V DC/100 mA                  with an extended input voltage and operating temperature range                  for railway applications</p>
--	---	--

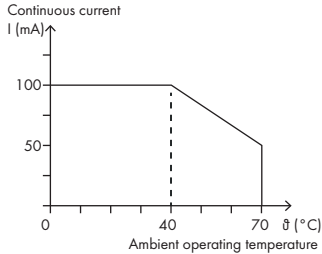

Derating

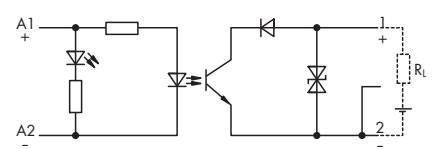
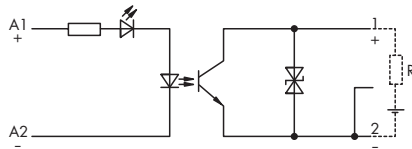
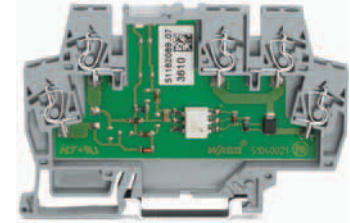
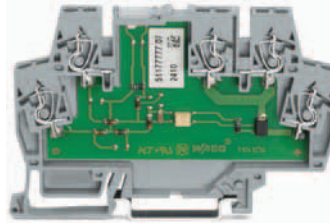

Description	$V_N$	$I_N$	Item No.	Pack. Unit	$V_N$	$I_N$	Item No.	Pack. Unit
Rail-mounted terminal block with optocoupler, for DIN 35 rail	24 V DC	9.2 mA	859-796	1	5 V DC	17 mA	859-795	1

Technical Data	Accessories see page 156	Accessories see page 156
<b>Control circuit:</b>		
Input voltage range (low level)	0 ... 5 VDC	0 ... 0.8 VDC
Input voltage range (high level)	18 ... 30 VDC	2 ... 6.25 VDC
<b>Load circuit:</b>		
Output voltage range	3 V ... 30 V DC	3 V ... 30 V DC
Max. continuous current	100 mA	100 mA
Turn-on time	10 µs	10 µs
Turn-off time	50 µs	50 µs
Max. switching frequency	10 kHz	10 kHz
Max. voltage drop at output	1 V	1 V
Reverse voltage transistor/triac	65 V	65 V
<b>General specifications:</b>		
Dielectric strength, control/load circuit (AC, 1 min)	2.5 kV <sub>rms</sub>	2.5 kV <sub>rms</sub>
Ambient operating temperature	-40 °C ... +70 °C	-40 °C ... +70 °C
Storage temperature	-40 °C ... +70 °C	-40 °C ... +70 °C
Dimensions (mm) W x H x L	6 x 56 x 91	6 x 56 x 91
Wire connection	Height from upper-edge of DIN 35 rail CAGE CLAMP®	Height from upper-edge of DIN 35 rail CAGE CLAMP®
Cross sections	0.08 mm <sup>2</sup> ... 2.5 mm <sup>2</sup> / AWG 28 ... 14	0.08 mm <sup>2</sup> ... 2.5 mm <sup>2</sup> / AWG 28 ... 14
Strip length	5 ... 6 mm / 0.2 ... 0.24 in	5 ... 6 mm / 0.2 ... 0.24 in
Standards/specifications	EN 60664-1; EN 61810-5; UL 508; EEx nA II T4	EN 60664-1; EN 61810-5; UL 508; EEx nA II T4





	<b>Power optocoupler</b> Input: 24 V DC Output: 24 V DC/3 A Negative switching	<b>Power optocoupler</b> Input: 24 V DC Output: 24 V DC/3 A
--	---	---

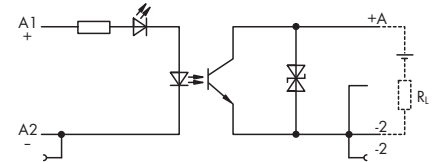
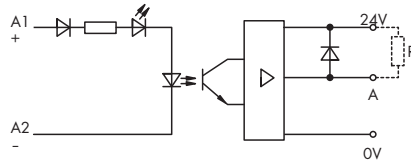
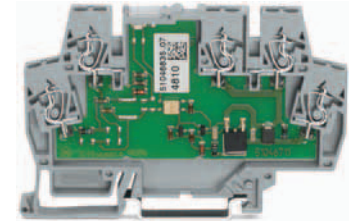
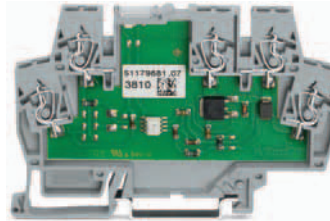
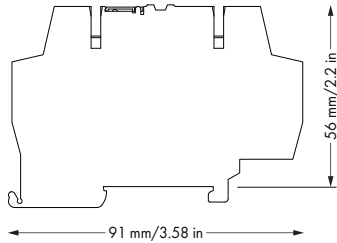

Description	V <sub>N</sub>	I <sub>N</sub>	Item No.	Pack. Unit	V <sub>N</sub>	I <sub>N</sub>	Item No.	Pack. Unit
Rail-mounted terminal block with optocoupler, for DIN 35 rail	24 V DC	4 mA	859-720	1	24 V DC	14 mA	859-730	1

Technical Data	Accessories see page 156	Accessories see page 156
<b>Control circuit:</b>		
Input voltage range (low level)		0 ... 5 VDC
Input voltage range (high level)	16 V ... 30 V DC	15 V ... 27 V DC
<b>Load circuit:</b>		
Output voltage range	10 V ... 30 V DC	3 V ... 30 V DC
Max. continuous current	3 A	3 A
Peak output current	20 A	25 A
Turn-on time	25 μs	25 μs
Turn-off time	75 μs	450 μs
Max. switching frequency	1 kHz / < 2 A, 2 kHz / < 1 A, 3 kHz / < 0.5 A	350 Hz
Max. voltage drop at output	0.5 V	0.2 V
Reverse voltage transistor/triac	55 V	55 V
<b>General specifications:</b>		
Dielectric strength, control/load circuit (AC, 1 min)	2.5 kV <sub>rms</sub>	2.5 kV <sub>rms</sub>
Ambient operating temperature	-25 °C ... +40 °C	-25 °C ... +55 °C
Storage temperature	-40 °C ... +70 °C	-40 °C ... +70 °C
Dimensions (mm) W x H x L	6 x 56 x 91	6 x 56 x 91
Wire connection	Height from upper-edge of DIN 35 rail CAGE CLAMP®	Height from upper-edge of DIN 35 rail CAGE CLAMP®
Cross sections	0.08 mm <sup>2</sup> ... 2.5 mm <sup>2</sup> / AWG 28 ... 14	0.08 mm <sup>2</sup> ... 2.5 mm <sup>2</sup> / AWG 28 ... 14
Strip length	5 ... 6 mm / 0.2 ... 0.24 in	5 ... 6 mm / 0.2 ... 0.24 in
Standards/specifications	EN 60664-1; EN 61810-5; UL 508; EEx nA II T4	EN 60664-1; EN 61810-5; UL 508; EEx nA II T4



	<b>Power optocoupler</b> Input: 24 VDC Output: 3 ... 30 VDC/3 A	<b>Power optocoupler</b> Input: 12 ... 48 VDC Output: 3 ... 53 VDC / 4 A
--	---	--

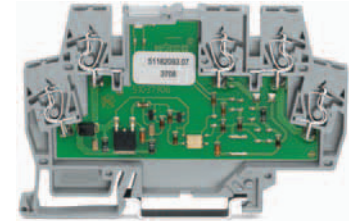
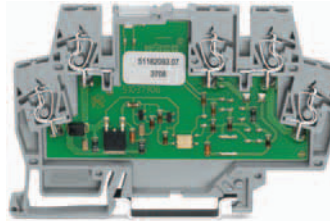
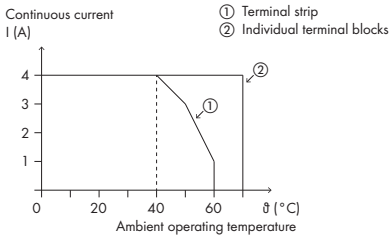

Derating 859-744

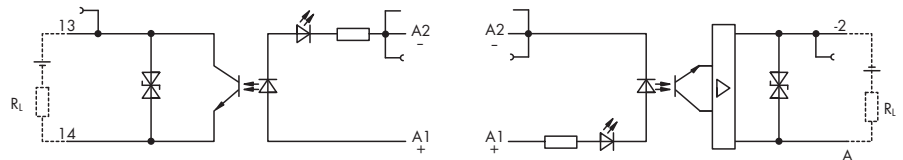

Description	V <sub>N</sub>	I <sub>N</sub>	Item No.	Pack. Unit	V <sub>N</sub>	I <sub>N</sub>	Item No.	Pack. Unit
Rail-mounted terminal block with optocoupler, for DIN 35 rail	24 VDC	7 mA	859-762	1	48 VDC	5 mA	859-744	1

Technical Data		Accessories see page 156	Accessories see page 156
<b>Control circuit:</b>			
Input voltage range (low level)	0 ... 9 VDC		0 ... 4 VDC
Input voltage range (high level)	19-27 VDC		10 ... 53 VDC
<b>Load circuit:</b>			
Output voltage range	3 ... 30 VDC		3 ... 53 VDC
Max. continuous current	3 A		4 A
Peak output current	25 A		30 A
Turn-on time	25 μs		200 μs
Turn-off time	450 μs		450 μs
Max. switching frequency	350 Hz		100 Hz
Max. voltage drop at output	0.2 V		0.2 V
Reverse voltage transistor/triac	55 V		80 V
<b>General specifications:</b>			
Dielectric strength, control/load circuit (AC, 1 min)	2.5 kV <sub>rms</sub>		2.5 kV <sub>rms</sub>
Ambient operating temperature	-25 °C ... +55 °C		-40 °C ... +70 °C (Derating must be observed)
Storage temperature	-40 °C ... +70 °C		-40 °C ... +70 °C
Dimensions (mm) W x H x L	6 x 56 x 91		6 x 56 x 91
Wire connection	Height from upper-edge of DIN 35 rail CAGE CLAMP®		Height from upper-edge of DIN 35 rail CAGE CLAMP®
Cross sections	0.08 mm <sup>2</sup> ... 2.5 mm <sup>2</sup> / AWG 28 ... 14		0.08 mm <sup>2</sup> ... 2.5 mm <sup>2</sup> / AWG 28 ... 14
Strip length	5 ... 6 mm / 0.2 ... 0.24 in		5 ... 6 mm / 0.2 ... 0.24 in
Standards/specifications	EN 60664-1		EN 60664-1

**Power optocoupler**  
**Input: 24 VDC**  
**Output: 3 ... 30 VDC / 5 A**

**Power optocoupler**  
**Input: 5 VDC**  
**Output: 3 ... 30 VDC / 5 A**

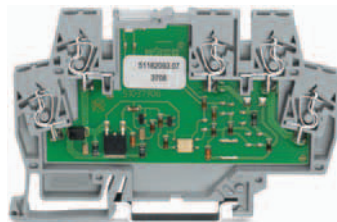
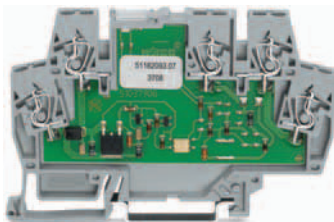
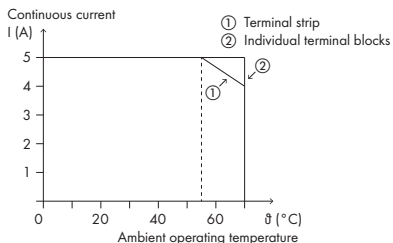

Derating

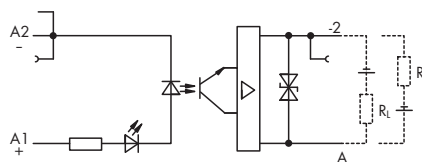
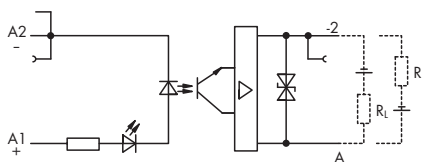

Description	$V_N$	$I_N$	Item No.	Pack. Unit	$V_N$	$I_N$	Item No.	Pack. Unit
<b>Rail-mounted terminal block with optocoupler, for DIN 35 rail</b>	24 VDC	3.5 mA	<b>859-737</b>	1	5 VDC	7.2 mA	<b>859-738</b>	1

Technical Data	Accessories see page 156				Accessories see page 156			
<b>Control circuit:</b>								
Input voltage range (low level)		0 ... 5 VDC				0 ... 2 VDC		
Input voltage range (high level)		15 ... 30 VDC				4 ... 6 VDC		
<b>Load circuit:</b>								
Output voltage range		3 ... 30 VDC				3 ... 30 VDC		
Max. continuous current		5 A				5 A		
Peak output current		25 A				25 A		
Turn-on time		200 $\mu$ s				200 $\mu$ s		
Turn-off time		450 $\mu$ s				450 $\mu$ s		
Max. switching frequency		100 Hz				100 Hz		
Max. voltage drop at output		0.2 V				0.2 V		
Reverse voltage transistor/triac		55 V				55 V		
<b>General specifications:</b>								
Dielectric strength, control/load circuit (AC, 1 min)		2.5 kV <sub>rms</sub>				2.5 kV <sub>rms</sub>		
Ambient operating temperature		-25 °C ... +70 °C				-25 °C ... +70 °C		
Storage temperature		-40 °C ... +70 °C				-40 °C ... +70 °C		
Dimensions (mm) W x H x L		6 x 56 x 91				6 x 56 x 91		
Wire connection		Height from upper-edge of DIN 35 rail CAGE CLAMP®				Height from upper-edge of DIN 35 rail CAGE CLAMP®		
Cross sections		0.08 mm <sup>2</sup> ... 2.5 mm <sup>2</sup> / AWG 28 ... 14				0.08 mm <sup>2</sup> ... 2.5 mm <sup>2</sup> / AWG 28 ... 14		
Strip length		5 ... 6 mm / 0.2 ... 0.24 in				5 ... 6 mm / 0.2 ... 0.24 in		
Standards/specifications		EN 60664-1				EN 60664-1		

	<b>Power optocoupler</b> Input: 12 VDC Output: 3 ... 30 VDC / 5 A	
--	---	--

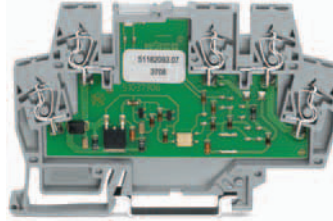
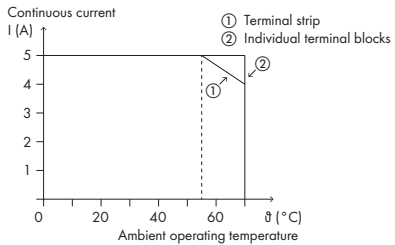

Derating

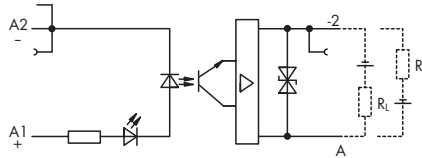

Description	V <sub>N</sub>	I <sub>N</sub>	Item No.	Pack. Unit
<b>Rail-mounted terminal block with optocoupler, for DIN 35 rail</b>	12 VDC	3.2 mA	<b>859-739</b>	1

**Technical Data**

Accessories see page 156

<b>Control circuit:</b>		
Input voltage range (low level)	0 ... 5 VDC	
Input voltage range (high level)	9.6 V ... 14.4 VDC	
<b>Load circuit:</b>		
Output voltage range	3 ... 30 VDC	
Max. continuous current	5 A	
Peak output current	25 A	
Turn-on time	200 µs	
Turn-off time	450 µs	
Max. switching frequency	100 Hz	
Max. voltage drop at output	0.2 V	
Reverse voltage transistor/triac	55 V	
<b>General specifications:</b>		
Dielectric strength, control/load circuit (AC, 1 min)	2.5 kV <sub>rms</sub>	
Ambient operating temperature	-25 °C ... +70 °C	
Storage temperature	-40 °C ... +70 °C	
Dimensions (mm) W x H x L	6 x 56 x 91	
Wire connection	Height from upper-edge of DIN 35 rail CAGE CLAMP®	
Cross sections	0.08 mm <sup>2</sup> ... 2.5 mm <sup>2</sup> / AWG 28 ... 14	
Strip length	5 ... 6 mm / 0.2 ... 0.24 in	
Standards/specifications	EN 60664-1	

# 2 Rail-Mounted Terminal Blocks with Optocoupler

	<b>Optocoupler</b> Input: 230 V AC Output: 24 VDC/0.5 A Positive switching increased input frequency up to 100 Hz Input voltage up to 270 V AC	<b>Optocoupler</b> Input: 230 V DC Output: 24 VDC/0.5 A Negative switching
--	--	---

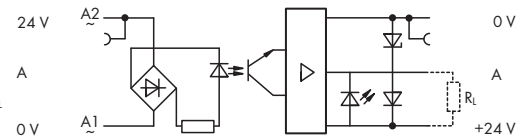
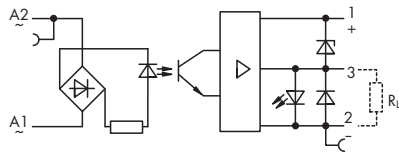
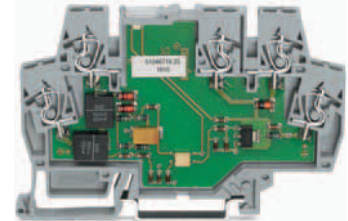
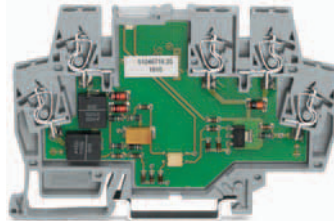
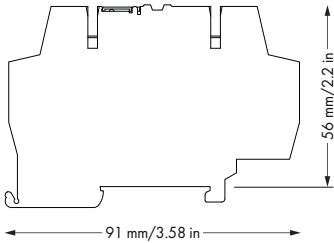

Description	V <sub>N</sub>	I <sub>N</sub>	Item No.	Pack. Unit	V <sub>N</sub>	I <sub>N</sub>	Item No.	Pack. Unit
Rail-mounted terminal block with optocoupler, for DIN 35 rail	230 V AC	0.6 mA	859-772	1	230 V AC	0.6 mA	859-712	1

Technical Data	Accessories see page 156				Accessories see page 156			
<b>Control circuit:</b>								
Input voltage range (low level)		0 ... 90 VAC				0 ... 90 VAC		
Input voltage range (high level)		175 ... 270 VAC				175 ... 240 VAC		
<b>Load circuit:</b>								
Output voltage range		20 V ... 30 V DC				20 V ... 30 V DC		
Max. continuous current		500 mA				500 mA		
Turn-on time		< 30 ms				< 30 ms		
Turn-off time		< 30 ms				< 30 ms		
Max. voltage drop at output		1.2 V				1.2 V		
Reverse voltage transistor/triac		80 V				80 V		
<b>General specifications:</b>								
Dielectric strength, control/load circuit (AC, 1 min)		2.5 kV <sub>rms</sub>				2.5 kV <sub>rms</sub>		
Ambient operating temperature		-25 °C ... +55 °C				-25 °C ... +55 °C		
Storage temperature		-40 °C ... +70 °C				-40 °C ... +70 °C		
Dimensions (mm) W x H x L		6 x 56 x 91				6 x 56 x 91		
Wire connection		Height from upper-edge of DIN 35 rail CAGE CLAMP®				Height from upper-edge of DIN 35 rail CAGE CLAMP®		
Cross sections		0.08 mm <sup>2</sup> ... 2.5 mm <sup>2</sup> / AWG 28 ... 14				0.08 mm <sup>2</sup> ... 2.5 mm <sup>2</sup> / AWG 28 ... 14		
Strip length		5 ... 6 mm / 0.2 ... 0.24 in				5 ... 6 mm / 0.2 ... 0.24 in		
Standards/specifications		EN 60664-1; UL 508; EEx nA II T4				EN 60664-1; UL 508; EEx nA II T4		

	<b>Optocoupler</b> <b>Input: 5 V DC</b> <b>Output: 24 VDC/0.5A/10 kHz</b> <b>Negative switching</b>	<b>Optocoupler</b> <b>Input: 24 V DC</b> <b>Output: 24 VDC/0.5A/10 kHz</b> <b>Negative switching</b>
--	--	---

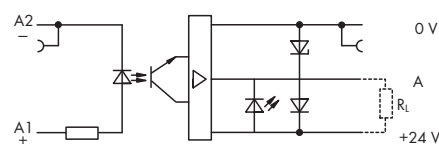
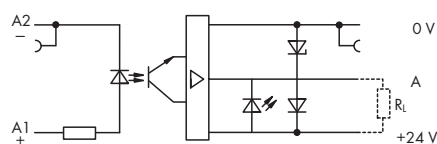
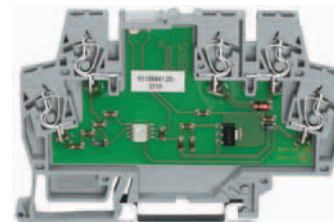
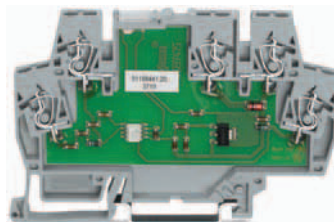
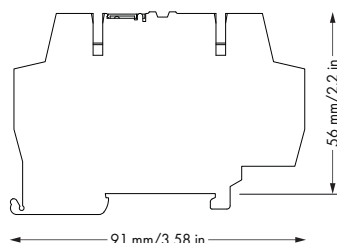

Description	V <sub>N</sub>	I <sub>N</sub>	Item No.	Pack. Unit	V <sub>N</sub>	I <sub>N</sub>	Item No.	Pack. Unit
Rail-mounted terminal block with optocoupler, for DIN 35 rail	5 V DC	9.6 mA	859-702	1	24 V DC	7.7 mA	859-708	1

**Technical Data**

Accessories see page 156

Accessories see page 156

Control circuit:		
Input voltage range (low level)	0 ... 1 VDC	0 ... 5 VDC
Input voltage range (high level)	4 ... 6.25 VDC	19 ... 30 VDC
<b>Load circuit:</b>		
Output voltage range	20 V ... 30 V DC	20 V ... 30 V DC
Max. continuous current	500 mA	500 mA
Turn-on time	< 7 µs	< 10 µs
Turn-off time	< 15 ms	< 10 µs
Max. switching frequency	10 kHz	10 kHz
Max. voltage drop at output	1.2 V	1.2 V
Reverse voltage transistor/triac	80 V	80 V
<b>General specifications:</b>		
Dielectric strength, control/load circuit (AC, 1 min)	2.5 kV <sub>rms</sub>	2.5 kV <sub>rms</sub>
Ambient operating temperature	-25 °C ... +55 °C	-25 °C ... +55 °C
Storage temperature	-40 °C ... +70 °C	-40 °C ... +70 °C
Dimensions (mm) W x H x L	6 x 56 x 91	6 x 56 x 91
Wire connection	Height from upper-edge of DIN 35 rail CAGE CLAMP®	Height from upper-edge of DIN 35 rail CAGE CLAMP®
Cross sections	0.08 mm <sup>2</sup> ... 2.5 mm <sup>2</sup> / AWG 28 ... 14	0.08 mm <sup>2</sup> ... 2.5 mm <sup>2</sup> / AWG 28 ... 14
Strip length	5 ... 6 mm / 0.2 ... 0.24 in	5 ... 6 mm / 0.2 ... 0.24 in
Standards/specifications	EN 60664-1; UL 508; EEx nA II T4	EN 60664-1; UL 508; EEx nA II T4

	<p><b>Optocoupler</b>                  Input: 5 VDC                  Output: 5 VDC / 500 mA/10 kHz                  Positive switching</p>	<p><b>Optocoupler</b>                  Input: 5 VDC                  Output: 12 VDC / 500 mA/10 kHz                  Positive switching</p>
--	--	---

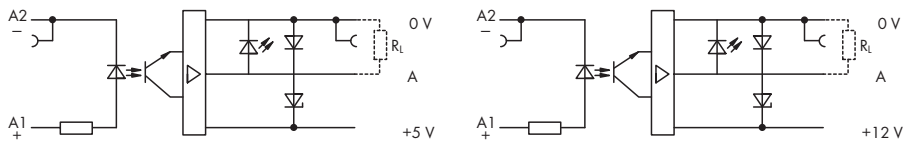
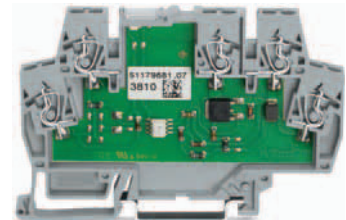
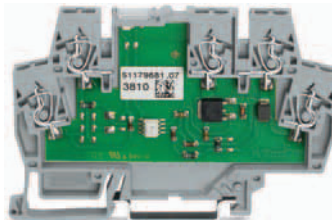
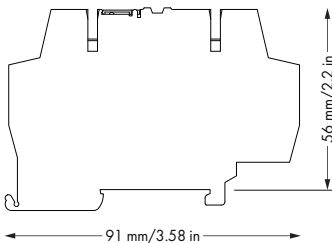

Description	V <sub>N</sub>	I <sub>N</sub>	Item No.	Pack. Unit	V <sub>N</sub>	I <sub>N</sub>	Item No.	Pack. Unit
Rail-mounted terminal block with optocoupler, for DIN 35 rail	5 VDC	8 mA	859-750	1	5 VDC	8 mA	859-751	1

Technical Data	Accessories see page 156				Accessories see page 156			
<b>Control circuit:</b>								
Input voltage range (low level)	0 ... 1 VDC				0 ... 1 VDC			
Input voltage range (high level)	4 ... 6.25 VDC				4 ... 6 VDC			
<b>Load circuit:</b>								
Output voltage range	4 ... 6.25 VDC				8 ... 18 VDC			
Max. continuous current	500 mA				500 mA			
Peak output current	4 A				4 A			
Turn-on time	< 15 μs				< 15 μs			
Turn-off time	< 30 μs				< 30 μs			
Max. switching frequency	10 kHz				10 kHz			
Max. voltage drop at output	1.2 V				1.2 V			
Reverse voltage transistor/triac	80 V				80 V			
<b>General specifications:</b>								
Dielectric strength, control/load circuit (AC, 1 min)	2.5 kV <sub>rms</sub>				2.5 kV <sub>rms</sub>			
Ambient operating temperature	-25 °C ... +40 °C				-25 °C ... +40 °C			
Storage temperature	-40 °C ... +70 °C				-40 °C ... +70 °C			
Dimensions (mm) W x H x L	6 x 56 x 91				6 x 56 x 91			
Wire connection	Height from upper-edge of DIN 35 rail CAGE CLAMP®				Height from upper-edge of DIN 35 rail CAGE CLAMP®			
Cross sections	0.08 mm <sup>2</sup> ... 2.5 mm <sup>2</sup> / AWG 28 ... 14				0.08 mm <sup>2</sup> ... 2.5 mm <sup>2</sup> / AWG 28 ... 14			
Strip length	5 ... 6 mm / 0.2 ... 0.24 in				5 ... 6 mm / 0.2 ... 0.24 in			
Standards/specifications	EN 60664-1; UL 508; EEx nA II T4				EN 60664-1; UL 508; EEx nA II T4			



	<b>Optocoupler</b> Input: 24 V DC Output: 5 VDC/0.5A/10 kHz Negative switching	<b>Optocoupler</b> Input: 24 VDC Output: 5 VDC/100 mA/100 kHz Positive switching
--	---	---

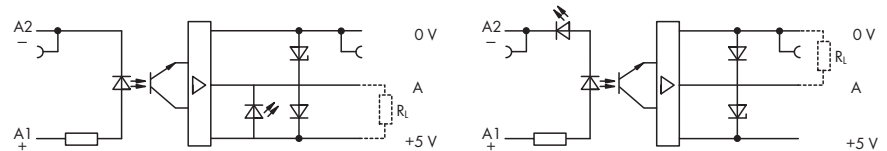
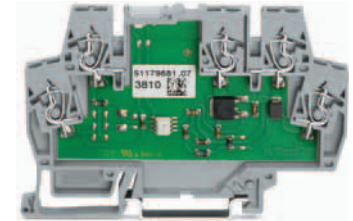
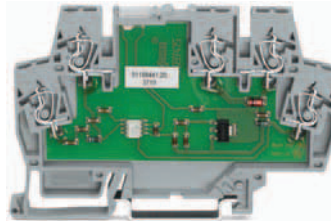
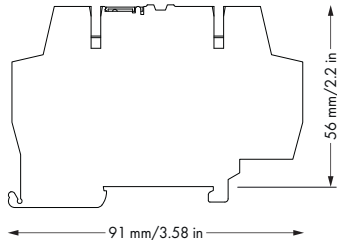

Description	V <sub>N</sub>	I <sub>N</sub>	Item No.	Pack. Unit	V <sub>N</sub>	I <sub>N</sub>	Item No.	Pack. Unit
Rail-mounted terminal block with optocoupler, for DIN 35 rail	24 V DC	11 mA	859-706	1	24 VDC	9 mA	859-755	1

Technical Data	Accessories see page 156				Accessories see page 156			
<b>Control circuit:</b>								
Input voltage range (low level)		0 ... 5 VDC				0 ... 5 VDC		
Input voltage range (high level)		18 ... 30 VDC				20 ... 30 VDC		
<b>Load circuit:</b>								
Output voltage range		4 V ... 6.25 V DC				4 ... 6 VDC		
Max. continuous current		500 mA				100 mA		
Peak output current						0.8 A		
Turn-on time		< 7 µs				< 0.5 µs		
Turn-off time		< 15 µs				< 2 µs		
Max. switching frequency		10 kHz				100 kHz		
Max. voltage drop at output		1.2 V				0.6 V		
Reverse voltage transistor/triac		80 V				40 V		
<b>General specifications:</b>								
Dielectric strength, control/load circuit (AC, 1 min)		2.5 kV <sub>rms</sub>				2.5 kV <sub>rms</sub>		
Ambient operating temperature		-25 °C ... +55 °C				-25 °C ... +55 °C		
Storage temperature		-40 °C ... +70 °C				-40 °C ... +70 °C		
Dimensions (mm) W x H x L		6 x 56 x 91				6 x 56 x 91		
Wire connection		Height from upper-edge of DIN 35 rail CAGE CLAMP®				Height from upper-edge of DIN 35 rail CAGE CLAMP®		
Cross sections		0.08 mm <sup>2</sup> ... 2.5 mm <sup>2</sup> / AWG 28 ... 14				0.08 mm <sup>2</sup> ... 2.5 mm <sup>2</sup> / AWG 28 ... 14		
Strip length		5 ... 6 mm / 0.2 ... 0.24 in				5 ... 6 mm / 0.2 ... 0.24 in		
Standards/specifications		EN 60664-1; UL 508; EEx nA II T4				EN 60664-1		

# 2 Rail-Mounted Terminal Blocks with Optocoupler

**Optocoupler**  
**Input: 5 V DC**  
**Output: 24 VDC/0.5 A/10 kHz**  
**Positive switching**

**Optocoupler**  
**Input: 5 VDC**  
**Output: 24 VDC/100 mA/100 kHz**  
**Positive switching**

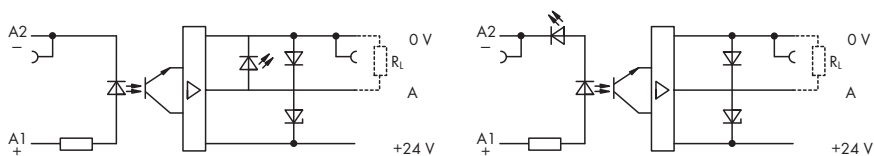
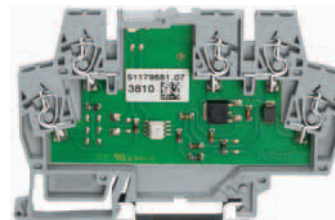
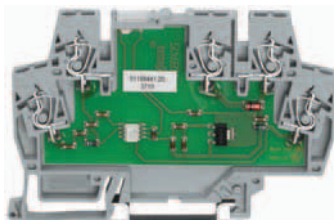
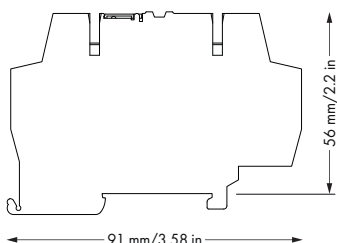

Description	V <sub>N</sub>	I <sub>N</sub>	Item No.	Pack. Unit	V <sub>N</sub>	I <sub>N</sub>	Item No.	Pack. Unit
Rail-mounted terminal block with optocoupler, for DIN 35 rail	5 V DC	10 mA	859-752	1	5 VDC	16.5 mA	859-753	1

**Technical Data** Accessories see page 156

	Accessories see page 156		Accessories see page 156	
<b>Control circuit:</b>				
Input voltage range (low level)		0 ... 1 VDC		0 ... 1 VDC
Input voltage range (high level)		4 ... 6 VDC		4 ... 6.25 VDC
<b>Load circuit:</b>				
Output voltage range		20 V ... 30 V DC		20 ... 28.8 VDC
Max. continuous current		500 mA		100 mA
Peak output current				0.8 A
Turn-on time		< 15 μs		< 0.5 μs
Turn-off time		< 30 μs		< 5 μs
Max. switching frequency		10 kHz		100 kHz
Max. voltage drop at output		1.2 V		0.6 V
Reverse voltage transistor/triac		80 V		40 V
<b>General specifications:</b>				
Dielectric strength, control/load circuit (AC, 1 min)		2.5 kV <sub>rms</sub>		2.5 kV <sub>rms</sub>
Ambient operating temperature		-25 °C ... +40 °C		-25 °C ... +55 °C
Storage temperature		-40 °C ... +70 °C		-40 °C ... +70 °C
Dimensions (mm) W x H x L		6 x 56 x 91		6 x 56 x 91
Wire connection		Height from upper-edge of DIN 35 rail CAGE CLAMP®		Height from upper-edge of DIN 35 rail CAGE CLAMP®
Cross sections		0.08 mm <sup>2</sup> ... 2.5 mm <sup>2</sup> / AWG 28 ... 14		0.08 mm <sup>2</sup> ... 2.5 mm <sup>2</sup> / AWG 28 ... 14
Strip length		5 ... 6 mm / 0.2 ... 0.24 in		5 ... 6 mm / 0.2 ... 0.24 in
Standards/specifications		EN 60664-1; UL 508; EEx nA II T4		EN 60664-1; UL 508

	<p><b>Optocoupler</b>  <b>Input: 24 VDC</b>  <b>Output: 24 VDC/100 mA/100 kHz</b>  <b>Positive switching</b></p>	<p><b>Optocoupler</b>  <b>Input: 24 V DC</b>  <b>Output: 5 V DC/0.5 A/10 kHz</b>  <b>Positive switching</b></p>
--	--	---

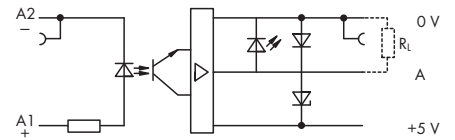
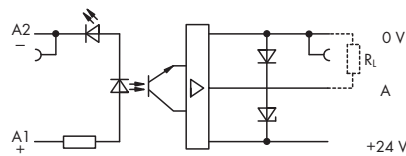
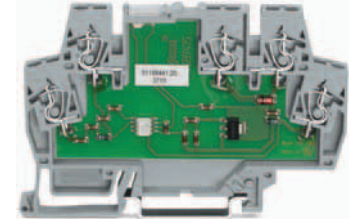
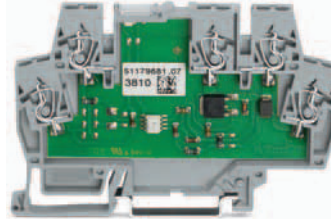
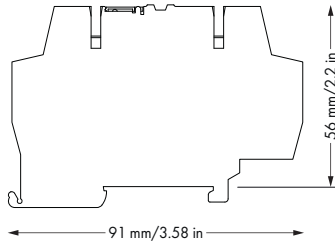

Description	V <sub>N</sub>	I <sub>N</sub>	Item No.	Pack. Unit	V <sub>N</sub>	I <sub>N</sub>	Item No.	Pack. Unit
Rail-mounted terminal block with optocoupler, for DIN 35 rail	24 VDC	9 mA	859-759	1	24 V DC	11 mA	859-756	1

Technical Data	Accessories see page 156				Accessories see page 156			
	Control circuit:				Control circuit:			
Input voltage range (low level)	0 ... 5 VDC				0 ... 5 VDC			
Input voltage range (high level)	20 ... 30 VDC				18 ... 30 VDC			
<b>Load circuit:</b>								
Output voltage range	20 ... 28.8 VDC				4 V ... 6.25 V DC			
Max. continuous current	100 mA				500 mA			
Peak output current	0.8 A							
Turn-on time	< 0.5 μs				< 15 μs			
Turn-off time	< 2 μs				< 30 μs			
Max. switching frequency	100 kHz				10 kHz			
Max. voltage drop at output	1.2 V				1.2 V			
Reverse voltage transistor/triac	40 V				80 V			
<b>General specifications:</b>								
Dielectric strength, control/load circuit (AC, 1 min)	2.5 kV <sub>rms</sub>				2.5 kV <sub>rms</sub>			
Ambient operating temperature	-25 °C ... +55 °C				-25 °C ... +40 °C			
Storage temperature	-40 °C ... +70 °C				-40 °C ... +70 °C			
Dimensions (mm) W x H x L	6 x 56 x 91				6 x 56 x 91			
Wire connection	Height from upper-edge of DIN 35 rail CAGE CLAMP®				Height from upper-edge of DIN 35 rail CAGE CLAMP®			
Cross sections	0.08 mm <sup>2</sup> ... 2.5 mm <sup>2</sup> / AWG 28 ... 14				0.08 mm <sup>2</sup> ... 2.5 mm <sup>2</sup> / AWG 28 ... 14			
Strip length	5 ... 6 mm / 0.2 ... 0.24 in				5 ... 6 mm / 0.2 ... 0.24 in			
Standards/specifications	EN 60664-1				EN 60664-1; UL 508; EEx nA II T4			



	<b>Optocoupler</b> Input: 24 VDC Output: 3 ... 30 VDC / 500 mA Changeover contact output	<b>Optocoupler</b> Input: 5 V DC Output: 230 V AC/0.5 A
--	---	---

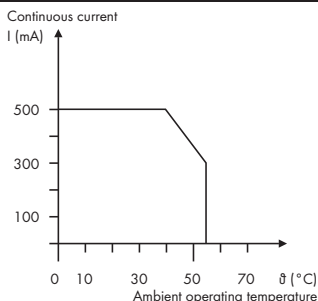

Derating

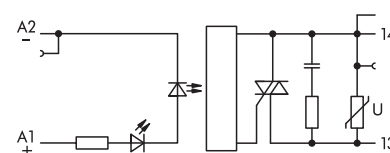
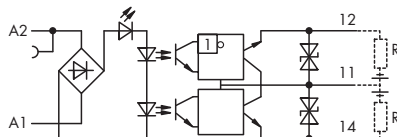
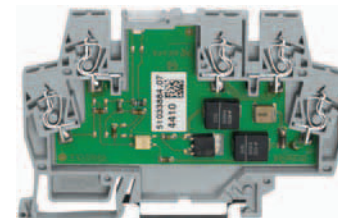
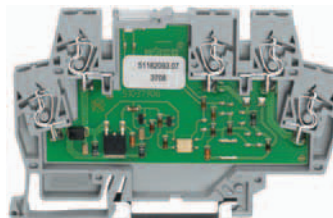

Description	V <sub>N</sub>	I <sub>N</sub>	Item No.	Pack. Unit	V <sub>N</sub>	I <sub>N</sub>	Item No.	Pack. Unit
<b>Rail-mounted terminal block with optocoupler, for DIN 35 rail</b>	24 VDC	5.3 mA	<b>859-732</b>	1	5 V DC	7.7 mA	<b>859-902</b>	1

**Technical Data**

Accessories see page 156

Accessories see page 156

Control circuit:		
Input voltage range (low level)	0 ... 5 VDC	0 ... 1 VDC
Input voltage range (high level)	15 V ... 42 VDC	4 ... 6.25 VDC
<b>Load circuit:</b>		
Output voltage range	3 ... 30 VDC	24 V ... 260 V AC (50 Hz ... 60 Hz)
Max. continuous current	500 mA	500 mA
Peak output current	4 A	30 A
Turn-on time	25 µs	10 ms
Turn-off time	150 µs	10 ms
Max. switching frequency	1.5 kHz	
Max. voltage drop at output	1.5 V	1.2 V
Reverse voltage transistor/triac	80 V	600 V
<b>General specifications:</b>		
Dielectric strength, control/load circuit (AC, 1 min)	3.75 kV <sub>rms</sub>	2.5 kV <sub>rms</sub>
Ambient operating temperature	-25 °C ... +55 °C	-25 °C ... +55 °C
Storage temperature	-25 °C ... +70 °C	-40 °C ... +70 °C
Dimensions (mm) W x H x L	6 x 56 x 91	6 x 56 x 91
Wire connection	Height from upper-edge of DIN 35 rail CAGE CLAMP®	Height from upper-edge of DIN 35 rail CAGE CLAMP®
Cross sections	0.08 mm <sup>2</sup> ... 2.5 mm <sup>2</sup> / AWG 28 ... 14	0.08 mm <sup>2</sup> ... 2.5 mm <sup>2</sup> / AWG 28 ... 14
Strip length	5 ... 6 mm / 0.2 ... 0.24 in	5 ... 6 mm / 0.2 ... 0.24 in
Standards/specifications	EN 60664-1; UL 508	EN 60664-1



# Rail-Mounted Terminal Blocks with Optocoupler

with an extended input voltage and operating temperature range, for railway applications

Rail-mounted terminal blocks with optocouplers

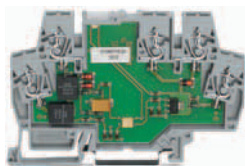

Description	Nominal input voltage (V <sub>N</sub> )	Input voltage range (high level)	Max. switching capacity	Ambient operating temperature at V <sub>N</sub>	Item No.	Pack. Unit
Optocoupler, 2-wire output	5 V DC	2 ... 6.25 VDC	3 V ... 30 V DC / 50 mA	-40 °C ... +70 °C	<b>859-795</b>	1
Optocoupler, 2-wire output	5 V DC	2 ... 6.25 VDC	3 V ... 60 V DC / 50 mA	-40 °C ... +70 °C	<b>859-793</b>	1
Optocoupler, 2-wire output	12 VDC	8.4 - 15 VDC	9 V ... 60 VDC / 50 mA	-40 °C ... +70 °C	<b>859-798</b>	1
Optocoupler, 2-wire output	24 V DC	18 ... 30 VDC	3 V ... 30 V DC / 50 mA	-40 °C ... +70 °C	<b>859-796</b>	1
Optocoupler, 2-wire output	24 V DC	16 ... 30 VDC	7 V ... 60 V DC / 50 mA	-40 °C ... +70 °C	<b>859-791</b>	1
Optocoupler, 2-wire output	24 V DC	16 V ... 30 V DC	9 V ... 60 V DC / 50 mA	-40 °C ... +70 °C	<b>859-794</b>	1

For additional technical data see: [www.wago.com](http://www.wago.com)

## 2 Accessories, 859 Series

156

Operating tool



Marking pen with fiber tip



Test pin



End and intermediate plate



Description	Item No.	Pack. Unit
End and intermediate plate; 1 mm / 0.039 in thick, gray	859-525	100 (4x25)
Test pin; Ø 1 mm / 0.039 in; test wire for sold. onto test plug	859-500	1
Marking pen for permanent marking	210-110	1
Operating tool, with partially insulated shaft Type 2, blade (3.5 x 0.5) mm	210-720	1

Push-in type jumper bar



Commoning

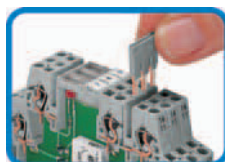

Description	Item No.	Pack. Unit	
Push-in type jumper bars, light gray, insulated, 18 A	2-way	859-402	200 (8x25)
	3-way	859-403	200 (8x25)
	4-way	859-404	200 (8x25)
	5-way	859-405	200 (8x25)
	6-way	859-406	100 (4x25)
	7-way	859-407	100 (4x25)
	8-way	859-408	100 (4x25)
	9-way	859-409	100 (4x25)
	10-way	859-410	100 (4x25)
	Item no. suffix for colored push-in type jumper bars	yellow	... /000-029
red		... /000-005	
blue		... /000-006	

Miniature quick marking card



Marking



Description	Item No.	Pack. Unit	
Miniature WSB Quick marking system plain	248-501	5 cards	
Marking software and printer/plotter see Section 11			
Marking	1 ... 10 (10 x)	248-502	5 cards
	11 ... 20 (10x)	248-503	5 cards
	21 ... 30 (10x)	248-504	5 cards
	31 ... 40 (10x)	248-505	5 cards
	41 ... 50 (10 x)	248-506	5 cards
	1 ... 50 (2 x)	248-566	5 cards
	K 1 ... K 10 (10 x)	248-450	5 cards
	K 11 ... K 20 (10 x)	248-451	5 cards
	K 100 (10 x)	248-452	5 cards
	U 1 ... U 10 (10 x)	248-453	5 cards
U 11 ... U 20 (10 x)	248-454	5 cards	
U 100 (10 x)	248-455	5 cards	
10 strips with 10 markers, white with black printing			