

Fieldbus Couplers

Housing Design I with System Power Supply	
Dimensions (mm) W x H x L	51 x 65 x 100 (Height from upper edge of the DIN-rail)
Wire connection	CAGE CLAMP®
Cross sections	0.08 mm² ... 2.5 mm² / 28 ... 14 AWG
Strip lengths	8 ... 9 mm / 0.33 in.

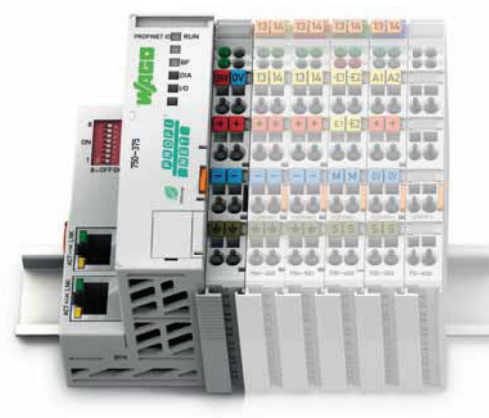

Housing Design II with System Power Supply	
Dimensions (mm) W x H x L	62 x 65 x 100 (Height from upper edge of the DIN-rail)



Housing Design without System Power Supply	
Dimensions (mm) W x H x L	50 x 65 x 97 (Height from upper edge of the DIN-rail)
Wire connection	CAGE CLAMP®
Cross sections	0.08 mm² ... 1.5 mm² / 28 ... 14 AWG
Strip lengths	5 ... 6 mm / 0.22 in.

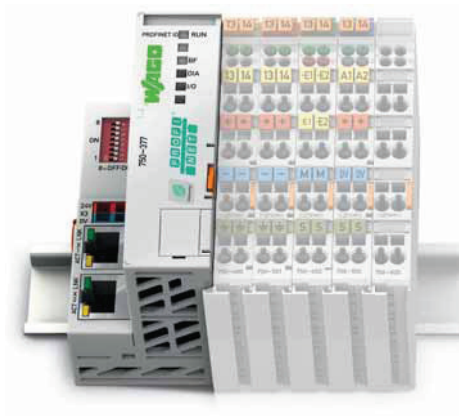



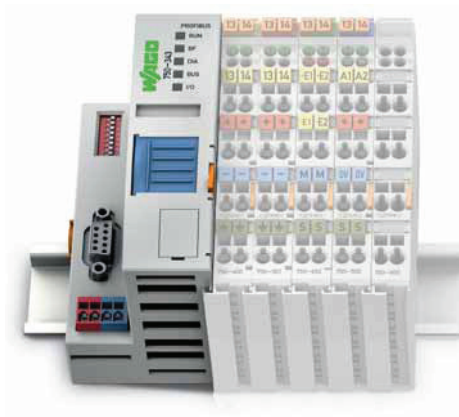









Housing Design ECO	
Dimensions (mm) W x H x L	50 x 65 x 97 (Height from upper edge of the DIN-rail)
Wire connection	CAGE CLAMP®
Cross sections	0.08 mm² ... 1.5 mm² / 28 ... 16 AWG
Strip lengths	5 ... 6 mm / 0.22 in.



Modular I/O-System Overview

Fieldbus Couplers

Fieldbus System	Housing Design				Description	Item No.	Page
	with System Power Supply		without System Power Supply	ECO			
							
	<input type="checkbox"/>				Fieldbus Coupler, 100 Mbit	750-340	128
	<input type="checkbox"/>				Fieldbus Coupler, 2-port, 100 Mbit	750-370	130
		<input type="checkbox"/>			Fieldbus Coupler, advanced, 2-port	750-375	132
		<input type="checkbox"/>			Fieldbus Coupler, advanced, 2-port, extended operating temperature range: -20 °C ... +60 °C	750-375/025-000	132
			<input type="checkbox"/>		Fieldbus Coupler, advanced, ECO, 2-port	750-377	134
			<input type="checkbox"/>		Fieldbus Coupler, advanced, ECO, 2-port, extended operating temperature range: -20 °C ... +60 °C	750-377/025-000	134
	<input type="checkbox"/>				DP/FMS Fieldbus Coupler, 12 Mbaud	750-303	136
	<input type="checkbox"/>				DP/V1 Fieldbus Coupler, 12 Mbaud	750-333	138
	<input type="checkbox"/>				DP/V1 Fieldbus Coupler, 12 Mbaud, extended operating temperature range: -20 °C ... +60 °C	750-333/025-000	138
				<input type="checkbox"/>	DP/ECO Fieldbus Coupler, 12 Mbaud	750-343	140
	<input type="checkbox"/>				Fieldbus Coupler with Fiber Optic Plug, 1.5 Mbaud	750-331	142
			<input type="checkbox"/>		Fieldbus Coupler, 10/100 Mbit	750-352	144
MODBUS/TCP	<input type="checkbox"/>				Fieldbus Coupler, 10 Mbit	750-342	146
			<input type="checkbox"/>		Fieldbus Coupler, 100 Mbit/s	750-354	148
			<input type="checkbox"/>		Fieldbus Coupler, ID-Switch, 100 Mbit/s	750-354/000-001	150
	<input type="checkbox"/>				Fieldbus Coupler	750-306	152
				<input type="checkbox"/>	ECO Fieldbus Coupler	750-346	154
	<input type="checkbox"/>				Fieldbus Coupler	750-307	156
	<input type="checkbox"/>				Fieldbus Coupler	750-337	158
	<input type="checkbox"/>				Fieldbus Coupler, extended operating temperature range: -20 °C ... +60 °C	750-337/025-000	158
	<input type="checkbox"/>				Fieldbus Coupler, D-Sub	750-338	160
				<input type="checkbox"/>	ECO Fieldbus Coupler	750-347	162
				<input type="checkbox"/>	ECO Fieldbus Coupler, D-Sub	750-348	164
	<input type="checkbox"/>				Fieldbus Coupler, 2-port., 100 Mbit	750-351	166
MODBUS	<input type="checkbox"/>				Fieldbus Coupler, RS-485 (150 ... 115.2 kbaud)	750-315/300-000	168
	<input type="checkbox"/>				Fieldbus Coupler, RS-232 (150 ... 115.2 kbaud)	750-316/300-000	170
	<input type="checkbox"/>				Fieldbus Coupler, 500 kbaud	750-304	172
				<input type="checkbox"/>	ECO Fieldbus Coupler, 500 kbaud	750-344	174
				<input type="checkbox"/>	ECO Fieldbus Coupler, 2 Mbaud	750-345	176
	<input type="checkbox"/>				Fieldbus Coupler with Fiber Optic Plug	750-334	178
	<input type="checkbox"/>				Fieldbus Coupler	750-310	180

PROFINET IO Fieldbus Coupler

10/100 Mbit/s; digital and analog signals



Fieldbus connection RJ-45

Configuration interface

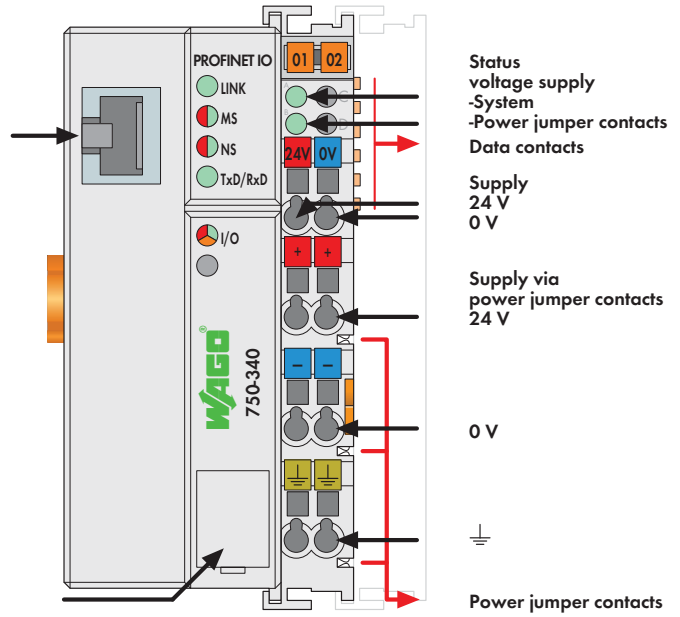

This fieldbus coupler connects the WAGO-I/O-SYSTEM as a slave to the PROFINET IO Industrial ETHERNET standard for automation. The fieldbus coupler supports all WAGO-I/O-SYSTEM modules.

The coupler automatically configures, creating a local process image which may include analog, digital, or specialty modules. Analog and specialty module data is sent via words and/or bytes; digital data is sent bit by bit.

The fieldbus coupler is integrated into the application as a PROFINET IO device.

Description	Item No.	Pack. Unit
PROFINET IO 100 MBit	750-340	1
Accessories		
Miniature WSB Quick marking system		
plain	248-501	5
with marking	see Section 11	
Approvals		
Conformity marking	CE	
Korea Certification	KC	
UL 508	UL 508	
TÜV 07 ATEX 554086 X	I M2 Ex d I Mb, II 3 G Ex nA IIC T4 Gc, II 3 D Ex tc IIIC T135°C Dc	
Permissible ambient temperature	0 °C ... +60 °C	
IECEx TUN 09.0001 X	Ex d I Mb, Ex nA IIC T4 Gc, Ex tc IIIC T135°C Dc	
Permissible ambient temperature	0 °C ... +60 °C	

System Data	
No. of couplers connected to Master	limited by PROFINET specification
Transmission medium	Twisted Pair S-UTP 100 Ω cat. 5
Max. length of fieldbus segment	100 m between hub station and 750-340; max. length of network limited by PROFINET specification
Baud rate	10/100 Mbit/s
Buscoupler connection	RJ-45
Protocols	PROFINET RT V2.0 (RT Class 1); Conformance Class A (DCP, UDP); HTTP

PROFINET IO Fieldbus Coupler

2-port; 100 Mbit/s; digital and analog signals



Fieldbus connection RJ-45

Fieldbus connection RJ-45

Dip switch

Configuration interface

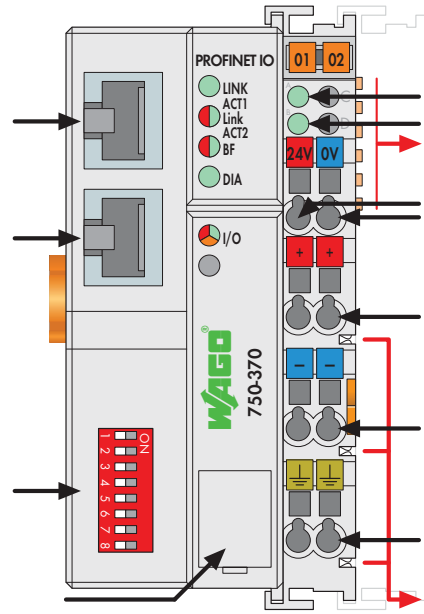

Status voltage supply
-System
-Power jumper contacts
Data contacts

Supply
24 V
0 V



Supply via power jumper contacts
24 V

0 V

⊥

Power jumper contacts

This fieldbus coupler connects to the WAGO-I/O-SYSTEM as a slave of the PROFINET IO, the open Industrial ETHERNET standard for automation. The fieldbus coupler supports all I/O modules. The buscoupler automatically configures, creating a local process image which may include analog, digital or specialty modules. Analog and specialty module data is sent via words and/or bytes; digital data is sent bit by bit. This buscoupler can integrate into the application as a PROFINET IO device. The buscoupler features an integrated 2-port switch, allowing easy line structure creation without requiring any additional network components. The device name can be assigned via DCP protocol or be adjusted by a DIP switch if the protocol is not supported by the control systems.

Description	Item No.	Pack. Unit
PROFINET IO 100 MBit 2-port	750-370	1
Accessories		
Miniature WSB Quick marking system		
 plain	248-501	5
with marking	see Section 11	
Approvals		
Conformity marking	CE	
Korea Certification		
UL 508		
ANSI/ISA 12.12.01	Class I, Div. 2, Grp. ABCD, T4	
TÜV 07 ATEX 554086 X	I M2 Ex d I Mb, II 3 G Ex nA IIC T4 Gc, II 3 D Ex tc IIIC T135°C Dc	
Permissible ambient temperature	0 °C ... +60 °C	
IECEx TUN 09.0001 X	Ex d I Mb, Ex nA IIC T4 Gc, Ex tc IIIC T135°C Dc	
Permissible ambient temperature	0 °C ... +60 °C	

System Data	
No. of couplers connected to Master	limited by PROFINET specification
Transmission medium	Twisted Pair S-UTP 100 Ω cat. 5
Max. length of fieldbus segment	100 m between switch and 750-370; max. length of network limited by PROFINET specification
Baud rate	10/100 Mbit/s
Buscoupler connection	2 x RJ-45
Protocols	PROFINET IO (RT Class 1); Conformance Class B (DCP, SNMP, LLDP); HTTP

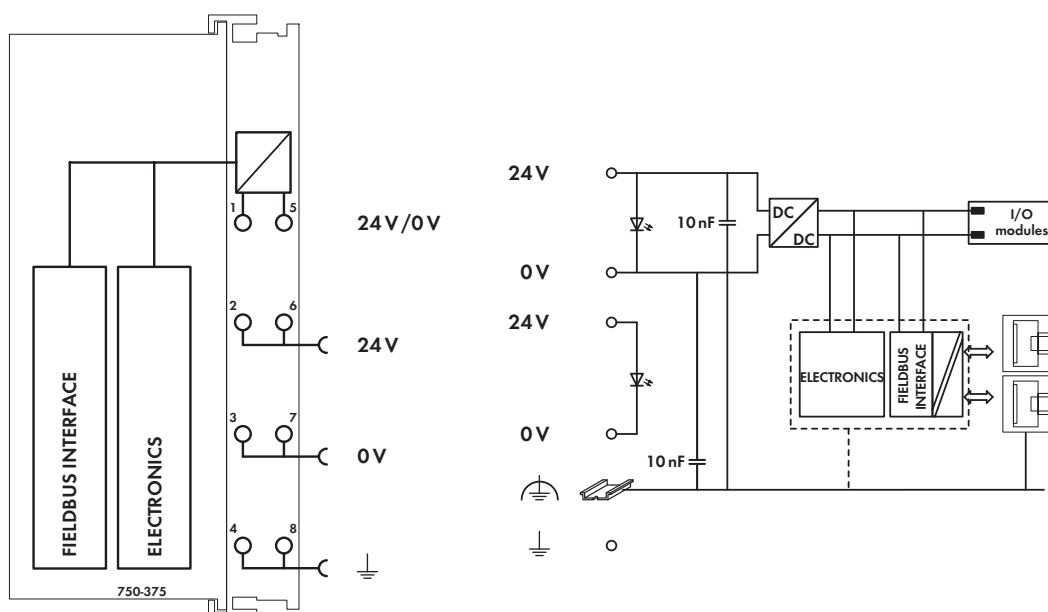

Technical Data	
Number of I/O modules	64
with bus extension	250
Max. input process image	512 bytes
Max. output process image	512 bytes
Configuration	via PC
PROFINET IO features	Integrated 2-port switch; Auto-negotiation, Auto-MDIX; Isochronous real-time communication (pending); Transmission clock: 1 ms (RT), 1, 2, 4 ms (IRT); Device replacement without programming tool; Shared device
Protocols	Topology detection / LLDP, Network diagnostics / SNMP / MIB-2, media redundancy / MRP (pending), Web server / HTTP
Profiles supported	PROFIsafe V2, PROFInergy V1.0
ID code	Vendor ID: 0x011D; Device ID: 0x02EE; Coupler ID: 0x01000177
Power supply	24 V DC (-25 % ... +30 %)
Input current typ. at rated load (24 V)	500 mA
Efficiency of the power supply (typ.) at nominal load (24 V)	90 %
Internal current consumption (5 V)	450 mA
Total current for I/O modules (5 V)	1700 mA
Isolation	500 V system/supply

General Specifications	
Operating temperature	0 °C ... +55 °C
Wire connection	CAGE CLAMP®
Cross sections	0.08 mm² ... 2.5 mm² / AWG 28 ... 14
Strip lengths	8 ... 9 mm / 0.33 in
Dimensions (mm) W x H x L	62 x 65 x 100
	Height from upper-edge of DIN 35 rail
Weight	150.3 g
Storage temperature	-25 °C ... +85 °C
Relative air humidity (no condensation)	95 %
Vibration resistance	acc. to IEC 60068-2-6
Shock resistance	acc. to IEC 60068-2-27
Degree of protection	IP20
EMC immunity of interference	acc. to EN 61000-6-2, marine applications
EMC emission of interference	acc. to EN 61000-6-3, marine applications

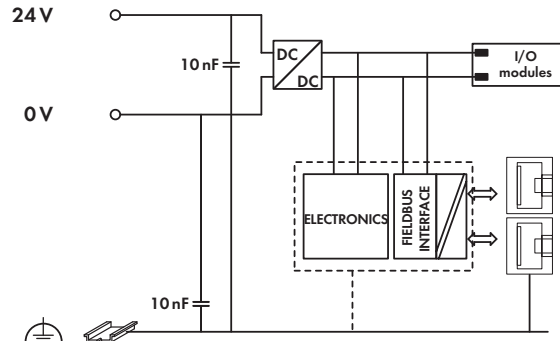
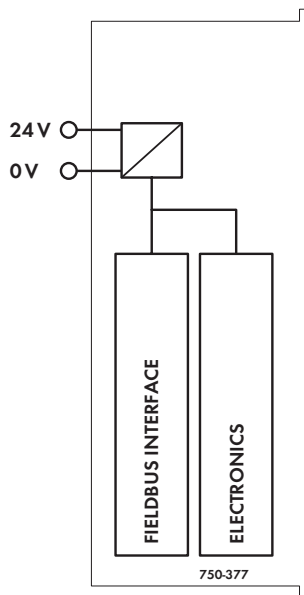

Technical Data	
Number of I/O modules	64
Max. input process image	256 bytes
Max. output process image	256 bytes
Configuration	via PC
PROFINET IO features	Integrated 2-port switch; Auto-negotiation, Auto-MDIX; Isochronous real-time communication (pending); Transmission clock: 1 ms (RT), 1, 2, 4 ms (IRT); Device replacement without programming tool
Protocols	Topology detection / LLDP, Network diagnostics / SNMP / MIB-2, media redundancy / MRP (pending), Web server / HTTP
Profiles supported	PROFIsafe V2, PROFIenergy V1.0
ID code	Vendor ID: 0x011D; Device ID: 0x02EE; Coupler ID: 0x01000179
Power supply	24 V DC (-25 % ... +30 %)
Input current typ. at rated load (24 V)	280 mA
Efficiency of the power supply (typ.) at nominal load (24 V)	90 %
Internal current consumption (5 V)	450 mA
Total current for I/O modules (5 V)	700 mA
Isolation	500 V system/supply

General Specifications	
Operating temperature	0 °C ... +55 °C
Wire connection	CAGE CLAMP®
Cross sections	0.08 mm² ... 1.5 mm² / AWG 28 ... 14
Strip lengths	5 ... 6 mm / 0.22 in
Dimensions (mm) W x H x L	50 x 65 x 97 Height from upper-edge of DIN 35 rail
Weight	107.1 g
Storage temperature	-25 °C ... +85 °C
Relative air humidity (no condensation)	95 %
Vibration resistance	acc. to IEC 60068-2-6
Shock resistance	acc. to IEC 60068-2-27
Degree of protection	IP20
EMC immunity of interference	acc. to EN 61000-6-2, marine applications
EMC emission of interference	acc. to EN 61000-6-3, marine applications

4 PROFIBUS DP/FMS Fieldbus Coupler

12 Mbaud; digital and analog signals

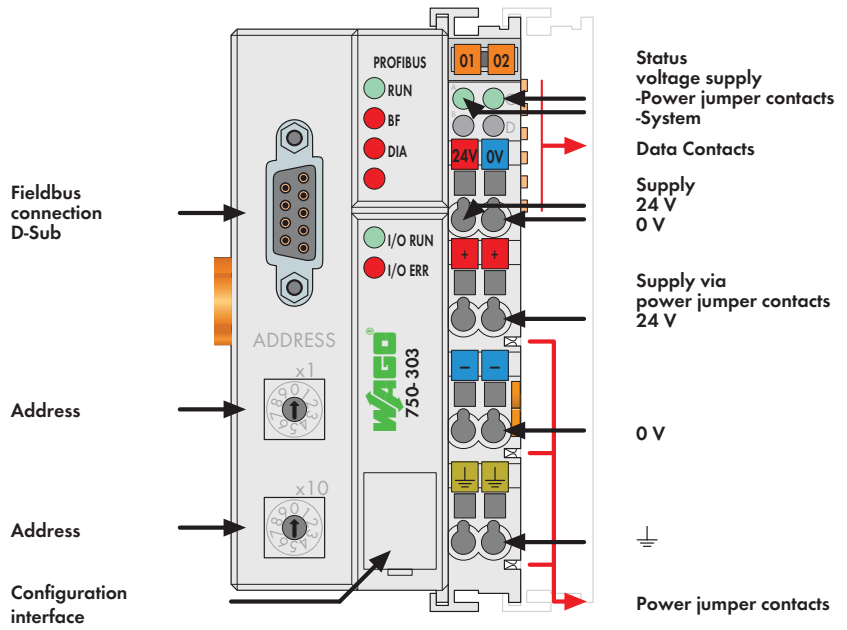

This buscoupler connects the WAGO-I/O-SYSTEM as a slave to the PROFIBUS fieldbus.

The buscoupler automatically configures, creating a local process image which may include analog, digital or specialty modules. Analog and specialty module data is sent via words and/or bytes, digital data is sent bit by bit.

PROFIBUS stores the process image in the corresponding Master control (PLC, PC or NC).

The local process image is divided into two data zones containing the data received and the data to be sent. The process data can be sent via the PROFIBUS fieldbus to the PLC, PC or NC for further processing, and received from the field via PROFIBUS.

The data of the analog modules is stored in the process image which is created automatically according to the order in which the modules are connected to the buscoupler. The bits of the digital modules are sent byte by byte and added to the analog data. If the amount of digital information exceeds 8 bits, the buscoupler automatically starts with a new byte.

When implementing new installations, please consider 750-333 PROFIBUS DP fieldbus coupler with extended functions. Notice: GSD files required!

Description	Item No.	Pack. Unit
PROFIBUS DP/FMS 12 Mbd	750-303	1
Accessories		
Download: www.wago.com		
GSD files		
Miniature WSB Quick marking system		
plain	248-501	5
with marking	see Section 11	
Standards and Approvals		
Standard	EN 50170	
Certification	PNO	
Conformity marking	CE	
Korea Certification	KC	
Marine applications	ABS, BV, DNV, GL, KR, LR, NKK, PRS, RINA	
UL 508	Class I, Div. 2, Grp. ABCD, T4	
ANSI/ISA 12.12.01	I M2 Ex d I Mb,	
TÜV 07 ATEX 554086 X	II 3 G Ex nA IIC T4 Gc,	
	II 3 D Ex tc IIIC T135°C Dc	
Permissible ambient temperature	0 °C ... +60 °C	
IECEx TUN 09.0001 X	Ex d I Mb,	
	Ex nA IIC T4 Gc,	
	Ex tc IIIC T135°C Dc	
Permissible ambient temperature	0 °C ... +60 °C	

System Data	
No. of couplers connected to Master	96 with repeater
Max. no. of I/O points	approx. 6000 (depends on master)
Transmission medium	Cu cable acc. to EN 50170
Max. length of fieldbus segment	100 m ... 1200 m (depends on baud rate/cable)
Baud rate	9.6 Kbaud ... 12 Mbaud
Transmission time	typ. 1 ms (10 couplers; 32 digital I/Os per coupler at 12 Mbaud) max. 3.3 ms
Buscoupler connection	1 x D-Sub 9; socket

4 PROFIBUS DP ECO Fieldbus Coupler

140 12 Mbaud; digital and analog signals



DIP switch Address

Fieldbus connection D-Sub

Supply 24 V 0 V

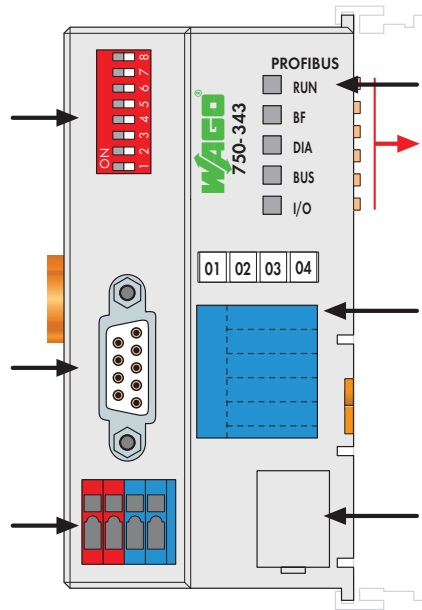

Status indication -Fieldbus -Fieldbus note

Data contacts

Marking area

Configuration interface

The ECO fieldbus coupler is designed for applications with a reduced scale I/O requirement. Using digital only process data or small amounts of analogs, while retaining all of the choice that's offered by the Series 750 I/O.

The coupler has an integrated supply terminal for the system voltage. The field power jumper contacts are supplied via a separate supply module.

When initializing, the buscoupler determines the module structure of the node, to create the process image in PROFIBUS. In order to optimize addresses, the I/O modules with a bit width smaller than 8 are grouped in one byte.

Notice: GSD files required

It is furthermore possible to deactivate I/O modules and to modify the image of the node according to the connected signals without having to modify the existing application.

The diagnosis concept is based on diagnostics according to the EN 50170 standard. Therefore the programming of modules is not necessary to interpret the diagnostic information from each manufacturer.

Description	Item No.	Pack. Unit
PROFIBUS DP ECO 12 MBd	750-343	1
Accessories		
GSD files	Download: www.wago.com	
Miniature WSB Quick marking system		
plain	248-501	5
with marking	see Section 11	
Standards and Approvals		
Standard	EN 50170	
Conformity marking	CE	
Korea Certification		
Marine applications	ABS, BV, DNV, GL, KR, LR, NKK, PRS, RINA	
UL 508		
ANSI/ISA 12.12.01	Class I, Div. 2, Grp. ABCD, T4	
TÜV 12.1297 X (Brasilien)	Ex nA IIC T4 Gc	
TÜV 07 ATEX 554086 X	I M2 Ex d I Mb, II 3 G Ex nA IIC T4 Gc, II 3 D Ex tc IIIC T135°C Dc	
Permissible ambient temperature	0 °C ... +60 °C	
IECEx TUN 09.0001 X	Ex d I Mb, Ex nA IIC T4 Gc, Ex tc IIIC T135°C Dc	
Permissible ambient temperature	0 °C ... +60 °C	

System Data	
No. of couplers connected to Master	125 with repeater
Max. no. of I/O points	approx. 6000 (depends on master)
Transmission medium	Cu cable acc. to EN 50170
Max. length of fieldbus segment	100 m ... 1200 m (depends on baud rate/cable)
Baud rate	9.6 Kbaud ... 12 Mbaud
Transmission time	typ. 1 ms (10 couplers; 32 digital I/Os per coupler at 12 Mbaud) max. 3.3 ms
Buscoupler connection	1 x D-Sub 9; socket

ETHERNET Fieldbus Coupler

10/100 Mbit/s; digital and analog signals

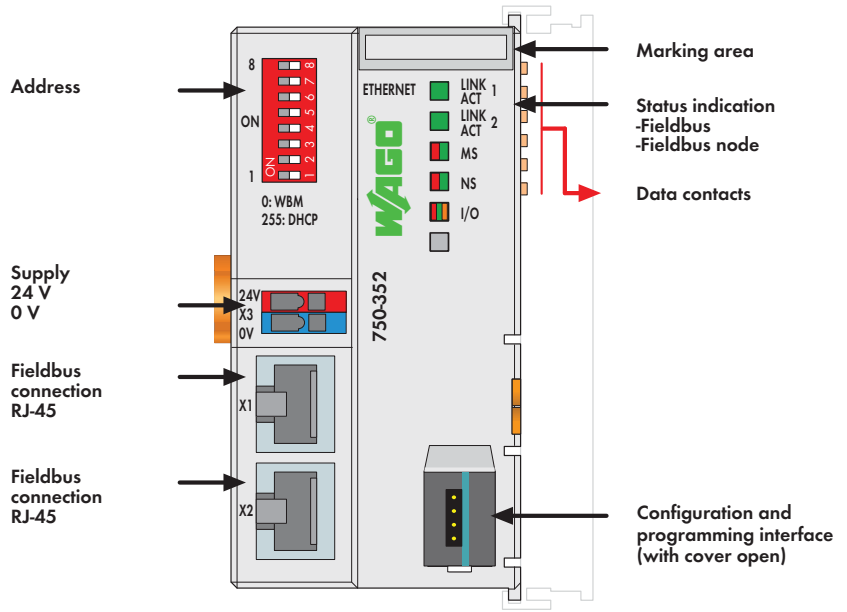

The 750-352 ETHERNET Fieldbus Coupler connects ETHERNET to the modular WAGO-I/O-SYSTEM.



The fieldbus coupler automatically configures, creating a local process image which may include analog, digital or specialty modules. Analog and specialty module data is sent via words and/or bytes; digital data is sent bit by bit.

Two ETHERNET interfaces and an integrated switch allow the fieldbus to be wired in a line topology. This eliminates additional network devices such as switches or hubs. Both interfaces support Auto-Negotiation and Auto-MDI(X).

The DIP switch configures the last byte of the IP address and may be used for IP address assignment (DHCP, BootP, static).

The coupler is designed for fieldbus communication in both Ethernet/IP and MODBUS networks. It also supports a wide variety of standard ETHERNET protocols (e.g., HTTP, BootP, DHCP, DNS, SNMP, FTP). An integrated Web server provides configuration and status information to the coupler.

The coupler has an integrated supply terminal for the system voltage. The field power jumper contacts are supplied via a separate supply module.

Description	Item No.	Pack. Unit
ETHERNET Coupler	750-352	1
Accessories		
Miniature WSB Quick marking system		
 plain	248-501	5
with marking	see Section 11	
Approvals		
Conformity marking	CE	
Korea Certification		
Marine applications	ABS, BV, DNV, GL, KR, LR, NKK, PRS, RINA	
UL 508	Class I, Div. 2, Grp. ABCD, T4	
ANSI/ISA 12.12.01	I M2 Ex d I Mb,	
TÜV 07 ATEX 554086 X	II 3 G Ex nA IIC T4 Gc,	
	II 3 D Ex tc IIIC T135°C Dc	
Permissible ambient temperature	0 °C ... +60 °C	
IECEx TUN 09.0001 X	Ex d I Mb,	
	Ex nA IIC T4 Gc,	
	Ex tc IIIC T135°C Dc	
Permissible ambient temperature	0 °C ... +60 °C	

System Data	
No. of couplers connected to Master	limited by ETHERNET specification
Transmission medium	Twisted Pair S-UTP
	100 Ω, Cat 5;
	Max. line length: 100 m
Baud rate	10/100 Mbit/s
Transmission performance	Class D acc. to EN 50173
Buscoupler connection	2 x RJ-45
Protocols	EtherNet/IP, MODBUS/TCP (UDP), HTTP, BootP, DHCP, DNS, FTP, SNMP

4 ETHERNET TCP/IP Fieldbus Coupler

146 10 Mbit/s; digital and analog signals



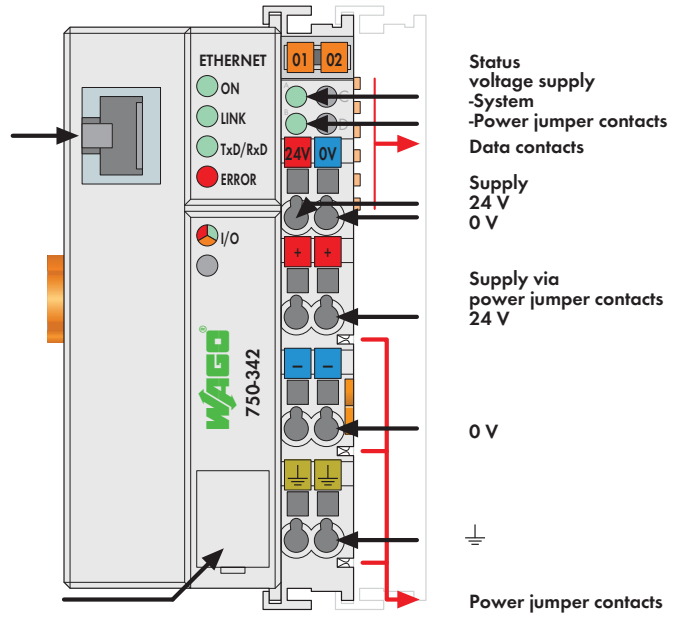

Fieldbus connection RJ-45

Configuration interface



The ETHERNET TCP/IP fieldbus coupler supports a number of network protocols to send process data via ETHERNET TCP/IP. By observing the relevant IT standards, connection to existing local or global networks (LAN, Internet) is possible without any problem. Using ETHERNET as a fieldbus makes universal data transmission between the factory and the office possible. Moreover, the ETHERNET TCP/IP fieldbus coupler offers remote maintenance, i.e. processes can be controlled regardless of the location. Process data exchange is done using the MODBUS/TCP protocol. The buscoupler supports all I/O modules and automatically configures, creating a local process image. The HTML pages that are stored in the fieldbus coupler allow access to

information on configuration, status, or I/O data of the ETHERNET TCP/IP fieldbus coupler. Only a standard WEB browser is required. Dynamic configuration of the IP addresses via a BootP server provides a flexible and easy way to configure the network.

Description	Item No.	Pack. Unit
ETHERNET TCP/IP 10 MBit	750-342	1
Accessories		
Miniature WSB Quick marking system		
 plain	248-501	5
with marking	see Section 11	
Approvals		
Conformity marking	CE	
Korea Certification		
Marine applications	ABS, BV, DNV, GL, KR, LR, NKK, PRS, RINA	
UL 508	UL 508	
ANSI/ISA 12.12.01	Class I, Div. 2, Grp. ABCD, T4	
TÜV 12.1297 X (Brasilien)	Ex nA IIC T4 Gc	
TÜV 07 ATEX 554086 X	I M2 Ex d I Mb, II 3 G Ex nA IIC T4 Gc, II 3 D Ex tc IIIC T135°C Dc	
Permissible ambient temperature	0 °C ... +60 °C	
IECEx TUN 09.0001 X	Ex d I Mb, Ex nA IIC T4 Gc, Ex tc IIIC T135°C Dc	
Permissible ambient temperature	0 °C ... +60 °C	

System Data	
No. of couplers connected to Master	limited by ETHERNET specification
Transmission medium	Twisted Pair S-UTP 100 Ω cat. 5
Max. length of fieldbus segment	100 m between hub station and 750-342; max. length of network limited by ETHERNET specification
Baud rate	10 Mbit/s
Buscoupler connection	RJ-45
Protocols	MODBUS/TCP, HTTP, BootP, MODBUS/UDP

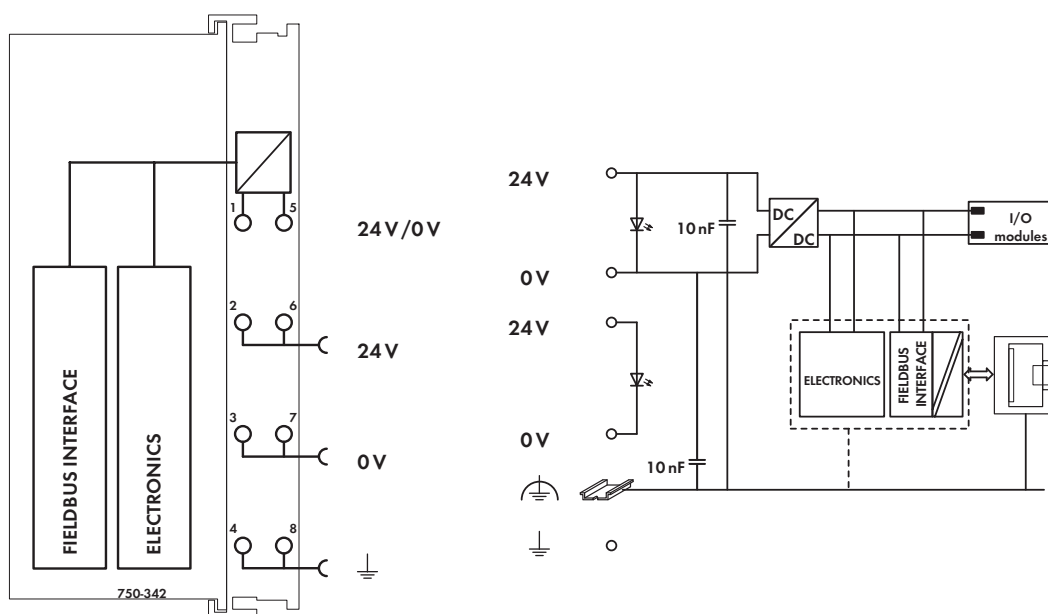

Technical Data

Number of I/O modules	64
Max. input process image	512 bytes
Max. output process image	512 bytes
Max. number of socket connections	1 HTTP; 3 MODBUS/TCP
Power supply	24 V DC (-25 % ... +30 %)
Max. input current (24 V)	500 mA
Power supply efficiency	87 %
Internal current consumption (5 V)	200 mA
Total current for I/O modules (5 V)	1800 mA
Isolation	500 V system/supply
Voltage via power jumper contacts	24 V DC (-25 % ... +30 %)
Current via power jumper contacts (max.)	10 A DC

General Specifications

Operating temperature	0 °C ... +55 °C
Wire connection	CAGE CLAMP®
Cross sections	0.08 mm ² ... 2.5 mm ² / AWG 28 ... 14
Strip lengths	8 ... 9 mm / 0.33 in
Dimensions (mm) W x H x L	51 x 65 x 100
	Height from upper-edge of DIN 35 rail
Weight	197 g
Storage temperature	-25 °C ... +85 °C
Relative air humidity (no condensation)	95 %
Vibration resistance	acc. to IEC 60068-2-6
Shock resistance	acc. to IEC 60068-2-27
Degree of protection	IP20
EMC immunity of interference	acc. to EN 61000-6-2, marine applications
EMC emission of interference	acc. to EN 61000-6-4, marine applications

EtherCAT Fieldbus Coupler

100 Mbit/s; digital and analog signals



Supply
24 V
0 V

Fieldbus connection
RJ-45

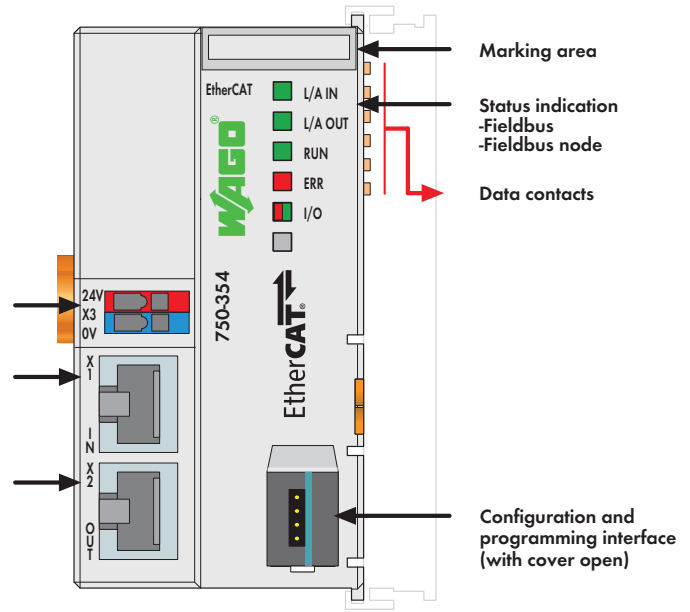

Fieldbus connection
RJ-45



The 750-354 EtherCAT Fieldbus Coupler connects EtherCAT to the modular WAGO-I/O-SYSTEM. The fieldbus coupler automatically configures, creating a local process image which may include analog, digital or specialty modules. Analog and specialty module data is sent via words and/or bytes; digital data is sent bit by bit.

EtherCAT® (Ethernet Control Automation Technology) is a real-time ETHERNET solution designed for industrial automation applications and characterized by high performance, flexible topology and simple configuration. With EtherCAT®, the costly ETHERNET star topology can be replaced with a simple line or tree structure.

The "upper" EtherCAT interface connects the coupler to the network. The "lower" RJ-45 socket connects additional EtherCAT devices to the same line.

Description	Item No.	Pack. Unit
EtherCAT® Coupler	750-354	1
Accessories		
Miniature WSB Quick marking system		
 plain	248-501	5
with marking	see Section 11	
Approvals		
Conformity marking	CE	
Korea Certification		
UL 508		
ANSI/ISA 12.12.01	Class I, Div. 2, Grp. ABCD, T4	
TÜV 07 ATEX 554086 X	I M2 Ex d I Mb, II 3 G Ex nA IIC T4 Gc, II 3 D Ex tc IIIC T135°C Dc	
Permissible ambient temperature	0 °C ... +60 °C	
IECEx TUN 09.0001 X	Ex d I Mb, Ex nA IIC T4 Gc, Ex tc IIIC T135°C Dc	
Permissible ambient temperature	0 °C ... +60 °C	

System Data	
No. of couplers connected to Master	limited by EtherCAT specification
Transmission medium	Shielded twisted pair
	S/FTP, F/FTP or SF/FTP;
	100 Ω, Cat 6
Baud rate	100 Mbit/s
Transmission performance	Class D acc. to EN 50173-1
Buscoupler connection	2 x RJ-45
Protocols	EtherCAT (direct mode)
EtherCAT® is registered trademark and patented technology, licensed by Beckhoff Automation GmbH, Germany.	

4 EtherCAT® Fieldbus Coupler, ID Switch

150 100 Mbit/s; digital and analog signals

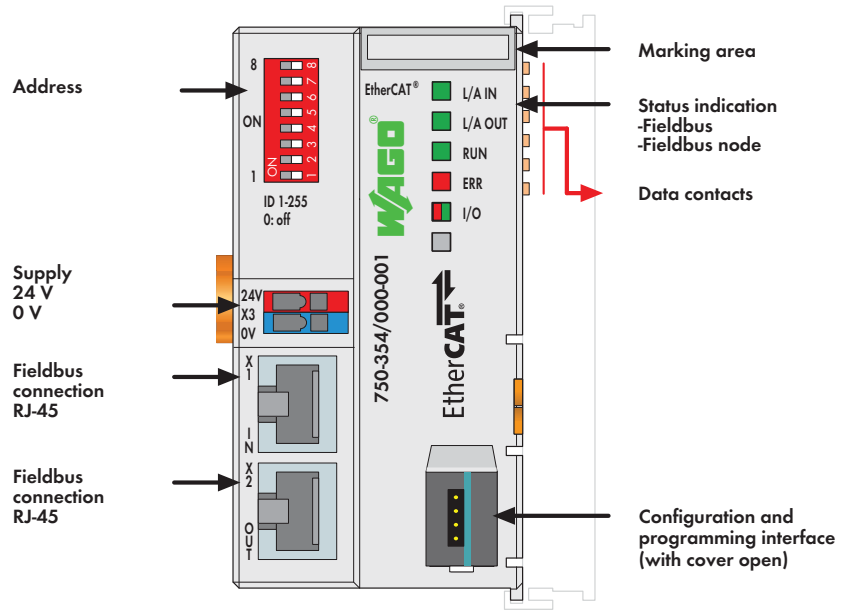

The 750-354 EtherCAT® Fieldbus Coupler connects EtherCAT® to the modular WAGO-I/O-SYSTEM.

The fieldbus coupler automatically configures, creating a local process image which may include analog, digital or specialty modules. Analog and specialty module data is sent via words and/or bytes; digital data is sent bit by bit.

The upper EtherCAT® interface connects the coupler to the network. The lower RJ-45 socket connects additional EtherCAT® devices to the same line.

EtherCAT® (Ethernet Control Automation Technology) is a real-time ETHERNET solution designed for industrial automation applications and characterized by high performance, flexible topology and simple configuration. With EtherCAT®, the costly ETHERNET star topology can be replaced with a simple line or tree structure.

The address selection switch is used to set an Explicit Device ID (EDI), which allows a fixed address to be assigned to an EtherCAT® slave.

Description	Item No.	Pack. Unit
EtherCAT® Fieldbus Coupler, ID Switch	750-354/000-001	1
Accessories		
Miniature WSB Quick marking system		
	plain	248-501
	with marking	see Section 11
Approvals		
Conformity marking	CE	
Marine applications	GL	
UL 508		

System Data	
No. of couplers connected to Master	limited by EtherCAT specification
Transmission medium	Shielded twisted pair
	S/FTP, F/FTP or SF/FTP;
	100 Ω, Cat 6
Baud rate	100 Mbit/s
Transmission performance	Class D acc. to EN 50173-1
Buscoupler connection	2 x RJ-45
Protocols	EtherCAT (direct mode)
EtherCAT® is registered trademark and patented technology, licensed by Beckhoff Automation GmbH, Germany.	

DeviceNet Fieldbus Coupler

125 ... 500 Kbaud; digital and analog signals

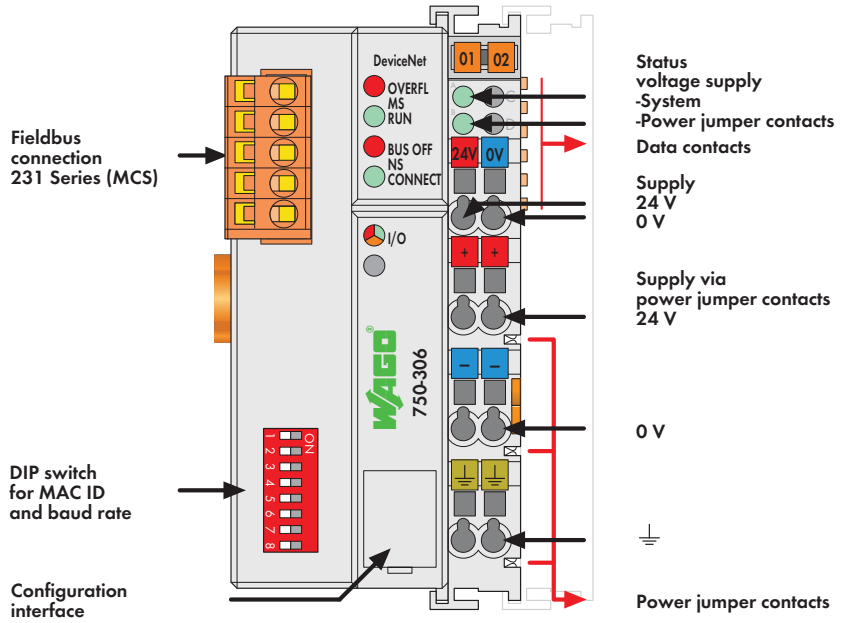

This buscoupler connects the WAGO-I/O-SYSTEM as a slave to the DeviceNet™ fieldbus.





The buscoupler automatically configures, creating a local process image which may include analog, digital or specialty modules. Analog and specialty module data is sent via words and/or bytes, digital data is sent bit by bit.

DeviceNet™ stores the process image in the corresponding Master control (PLC, PC or NC).

Notice: EDS files required

The local process image is divided into two data zones containing the data received and the data to be sent. The process data can be sent via the DeviceNet™ fieldbus to the PLC, PC or NC for further processing, and received from the field via DeviceNet™.

The data of the analog modules is stored in the process image which is created automatically according to the order in which the modules are connected to the buscoupler. The bits of the digital modules are sent byte by byte and added to the analog data. If the amount of digital information exceeds 8 bits, the buscoupler automatically starts with a new byte.

Description	Item No.	Pack. Unit
DeviceNet, w/ status byte	750-306	1
DeviceNet (only function with digital modules)	750-306/000-005	1
DeviceNet (without buskoppler status byte)	750-306/000-006	1
Accessories		
EDS files Download: www.wago.com		
Miniature WSB Quick marking system		
	plain 248-501	5
	with marking see Section 11	
Approvals		
Certification	ODVA	
Conformity marking	CE	
Korea Certification		
Marine applications (versions upon request)	ABS, BV, DNV, GL, KR, LR, NKK, PRS, RINA	
 UL 508		
 ANSI/ISA 12.12.01	Class I, Div. 2, Grp. ABCD, T4	
 TÜV 07 ATEX 554086 X	I M2 Ex d I Mb, II 3 G Ex nA IIC T4 Gc, II 3 D Ex tc IIIC T135°C Dc	
Permissible ambient temperature	0 °C ... +60 °C	
IECEx TUN 09.0001 X	Ex d I Mb, Ex nA IIC T4 Gc, Ex tc IIIC T135°C Dc	
Permissible ambient temperature	0 °C ... +60 °C	

System Data	
No. of couplers connected to Master	64 with scanner
Max. no. of I/O points	approx. 6000 (depends on master)
Transmission medium	Shielded Cu cable Trunk line: 2 x 0.82 mm ² + 2 x 1.7 mm ² Drop line: 2 x 0.2 mm ² + 2 x 0.32 mm ²
Max. length of bus line	100 m ... 500 m (depends on baud rate/cable)
Baud rate	125 Kbaud, 250 Kbaud, 500 Kbaud
Buscoupler connection	5-pole male connector, 231 Series (MCS), female connector 231-305/ 010-000/ 050-000 (included)

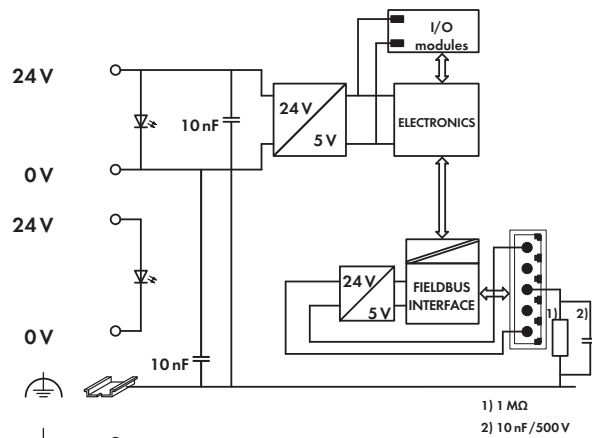
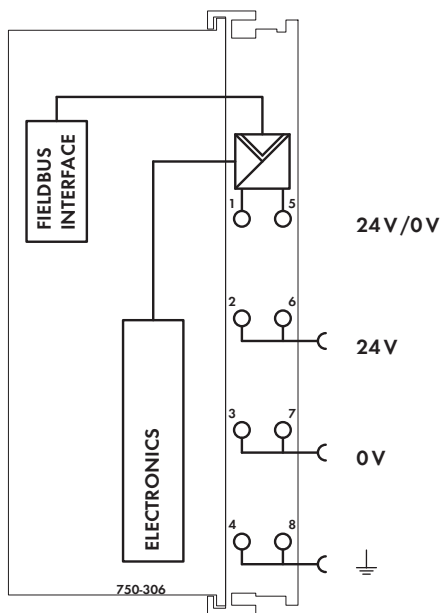

Technical Data	
Number of I/O modules	64
Max. input process image	512 bytes
Max. output process image	512 bytes
Configuration	via PC or PLC
DeviceNet features	Polled I/O message connection Strobed I/O message connection Change of state Cyclic message connection Group 2 only, slave
Power supply	24 V DC (-25 % ... +30 %)
Current consumption	
via power supply terminal	< 500 mA / 24 V
via DeviceNet interface	< 120 mA / 11 V
Power supply efficiency	87 %
Internal current consumption (5 V)	350 mA
Total current for I/O modules (5 V)	1650 mA
Isolation	500 V system/supply
Voltage via power jumper contacts	24 V DC (-25 % ... +30 %)
Current via power jumper contacts (max.)	10 A DC

General Specifications	
Operating temperature	0 °C ... +55 °C
Wire connection	CAGE CLAMP®
Cross sections	0.08 mm ² ... 2.5 mm ² / AWG 28 ... 14
Strip lengths	8 ... 9 mm / 0.33 in
Dimensions (mm) W x H x L	51 x 65 x 100
	Height from upper-edge of DIN 35 rail
Weight	200 g
Storage temperature	-25 °C ... +85 °C
Relative air humidity (no condensation)	95 %
Vibration resistance	acc. to IEC 60068-2-6
Shock resistance	acc. to IEC 60068-2-27
Degree of protection	IP20
EMC immunity of interference	acc. to EN 61000-6-2, marine applications
EMC emission of interference	acc. to EN 61000-6-4, marine applications

4 DeviceNet ECO Fieldbus Coupler

154 125 ... 500 Kbaud; digital and analog signals

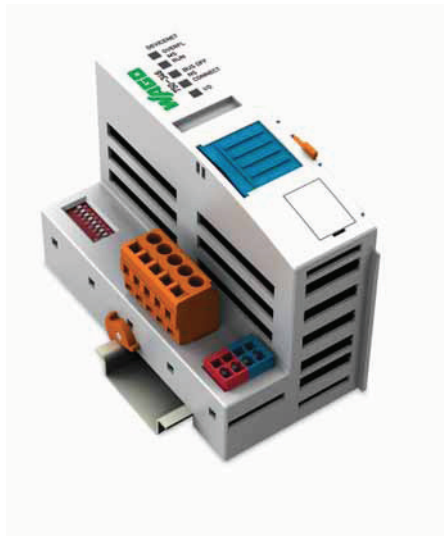

DIP switch for MAC ID and baud rate

Fieldbus connection 231 Series (MCS)

Supply 24 V 0 V

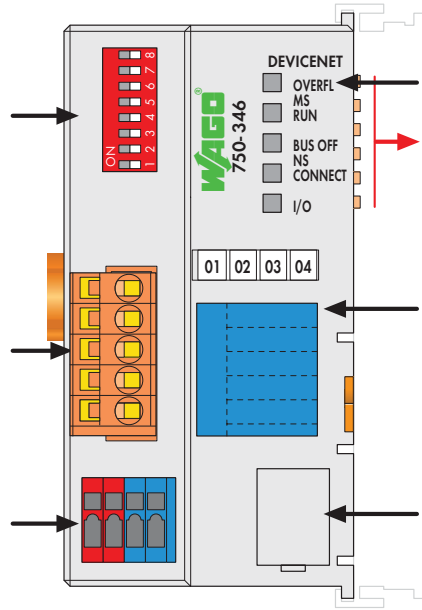

Status indication -Fieldbus -Fieldbus note

Data contacts

Marking area

Configuration interface

The ECO fieldbus coupler is designed for applications with a reduced scale I/O requirement. Using digital only process data or small amounts of analogs, while retaining all of the choice that's offered by the Series 750 I/O.



The coupler has an integrated supply terminal for the system voltage. The field power jumper contacts are supplied via a separate supply module.

The DeviceNet™ buscoupler automatically configures, creating a local process image which may include analog, digital or specialty modules. DeviceNet™ stores the process image in the corresponding Master control (PLC, PC or NC).

Notice: EDS files required

The local process image is divided into two data zones containing the data received and the data to be sent. The process data can be sent via the DeviceNet™ fieldbus to the PLC, PC or NC for further processing, and received from the field via DeviceNet™.

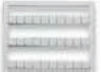
The data of the analog modules is stored in the process image which is created automatically according to the order in which the modules are connected to the buscoupler. The bits of the digital modules are sent byte by byte and added to the analog data. If the amount of digital information exceeds 8 bits, the buscoupler automatically starts with a new byte.

Description	Item No.	Pack. Unit
DeviceNet ECO	750-346	1
Accessories		
EDS files	Download: www.wago.com	
Miniature WSB Quick marking system		
	plain	248-501 5
	with marking	see Section 11
Approvals		
Conformity marking	CE	
Korea Certification		
UL 508		
ANSI/ISA 12.12.01	Class I, Div. 2, Grp. ABCD, T4	
TÜV 12.1297 X (Brasilien)	Ex nA IIC T4 Gc	
TÜV 07 ATEX 554086 X	I M2 Ex d I Mb, II 3 G Ex nA IIC T4 Gc, II 3 D Ex tc IIIC T135°C Dc	
Permissible ambient temperature	0 °C ... +60 °C	
IECEx TUN 09.0001 X	Ex d I Mb, Ex nA IIC T4 Gc, Ex tc IIIC T135°C Dc	
Permissible ambient temperature	0 °C ... +60 °C	

System Data	
No. of couplers connected to Master	64 with scanner
Max. no. of I/O points	approx. 6000 (depends on master)
Transmission medium	Shielded Cu cable Trunk line: 2 x 0.82 mm ² + 2 x 1.7 mm ² Drop line: 2 x 0.2 mm ² + 2 x 0.32 mm ²
Max. length of bus line	100 m ... 500 m (depends on baud rate/cable)
Baud rate	125 Kbaud, 250 Kbaud, 500 Kbaud
Buscoupler connection	5-pole male connector, 231 Series (MCS), female connector 231-305/ 010-000/ 050-000 (included)

CANopen Fieldbus Coupler

10 Kbaud ... 1 Mbaud; digital and analog signals

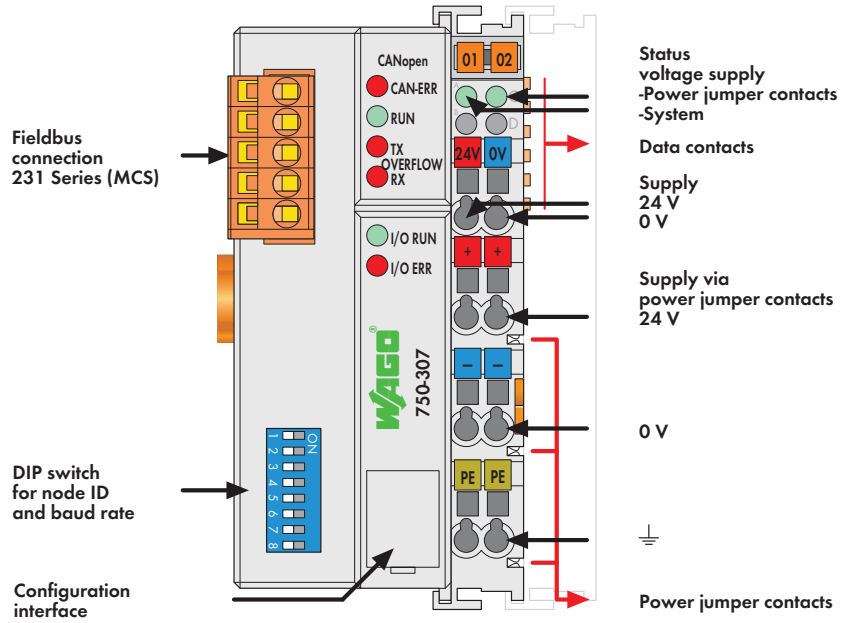

This buscoupler connects the WAGO-I/O-SYSTEM as a slave to the CANopen fieldbus. The module data is transmitted using PDOs and SDOs.

The buscoupler automatically configures, creating a local process image which may include analog, digital or specialty modules. Analog and specialty module data is sent via words and/or bytes, digital data is sent bit by bit.



The local process image is divided into two data zones containing the data received and the data to be sent. The process data can be sent via the CANopen fieldbus to the PLC, PC or NC for further processing, and received from the field via CANopen.

The data of the analog modules is stored in the PDOs according to the order in which the modules are connected to the buscoupler. The bits of the digital modules are sent byte by byte and also mapped in the PDOs. If the amount of digital information exceeds 8 bits, the buscoupler automatically starts with a new byte.

All entries of the object dictionary can be mapped - as the user likes - in the 5 Rx PDOs and 5 Tx PDOs.

The complete input and output process image can be transmitted using SDOs.

When implementing new installations, please consider 750-337 fieldbus coupler with extended functions. Notice: EDS files required!

Description	Item No.	Pack. Unit
CANopen	750-307	1
Accessories		
EDS files	Download: www.wago.com	
Miniature WSB Quick marking system		
	plain	248-501 5
	with marking	see Section 11
Approvals		
Conformity marking	CE	
Korea Certification		
UL 508		
ANSI/ISA 12.12.01	Class I, Div. 2, Grp. ABCD, T4	
TÜV 07 ATEX 554086 X	I M2 Ex d I Mb, II 3 G Ex nA IIC T4 Gc, II 3 D Ex tc IIIC T135°C Dc	
Permissible ambient temperature	0 °C ... +60 °C	
IECEx TUN 09.0001 X	Ex d I Mb, Ex nA IIC T4 Gc, Ex tc IIIC T135°C Dc	
Permissible ambient temperature	0 °C ... +60 °C	

System Data	
No. of couplers connected to Master	110
Transmission medium	Shielded Cu cable 3 x 0.25 mm ²
Max. length of bus line	30 m ... 1000 m (depends on baud rate/cable)
Baud rate	10 Kbaud ... 1 Mbaud
Buscoupler connection	5-pole male connector, 231 Series (MCS), female connector 231-305/ 010-000 (included)

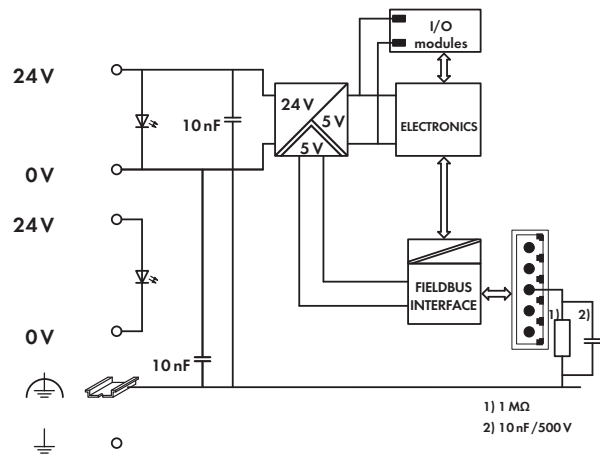
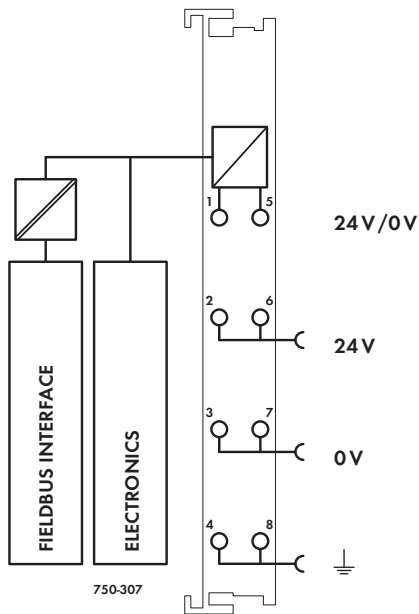

1) 1 MΩ
2) 10 nF/500V

Technical Data	
Number of I/O modules	64
Max. input process image	512 bytes
Max. output process image	512 bytes
Configuration	via PC or PLC
No. of PDOs	5 Tx / 5 Rx
No. of SDOs	2 server SDOs
Communication profile	DS-301 V3.0
Device profile	DS-401 V1.4
COB ID distribution	SDO, standard
Node ID distribution	DIP switches
Other CANopen features	NMT slave
	Minimum boot-up
	Variable PDO mapping
	Emergency message
	Life guarding
Power supply	24 V DC (-15 % ... +20 %)
Max. input current (24 V)	500 mA
Power supply efficiency	87 %
Internal current consumption (5 V)	350 mA
Total current for I/O modules (5 V)	1650 mA
Isolation	500 V system/supply
Voltage via power jumper contacts	24 V DC (-15 % ... +20 %)
Current via power jumper contacts (max.)	10 A DC

General Specifications	
Operating temperature	0 °C ... +55 °C
Wire connection	CAGE CLAMP®
Cross sections	0.08 mm² ... 2.5 mm² / AWG 28 ... 14
Strip lengths	8 ... 9 mm / 0.33 in
Dimensions (mm) W x H x L	51 x 65 x 100
	Height from upper-edge of DIN 35 rail
Weight	200 g
Storage temperature	-25 °C ... +85 °C
Relative air humidity (no condensation)	95 %
Vibration resistance	acc. to IEC 60068-2-6
Shock resistance	acc. to IEC 60068-2-27
Degree of protection	IP20
EMC immunity of interference	acc. to EN 61000-6-2
EMC emission of interference	acc. to EN 61000-6-4

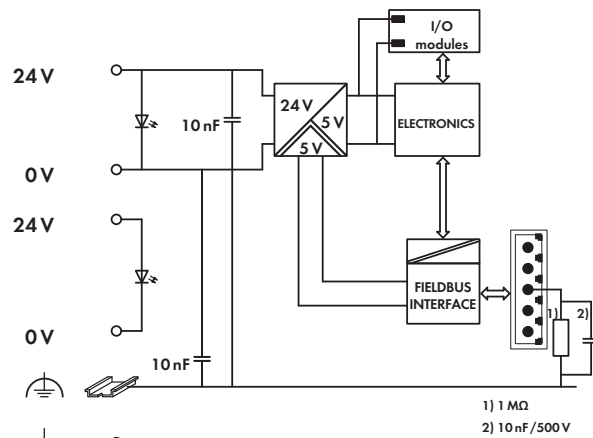
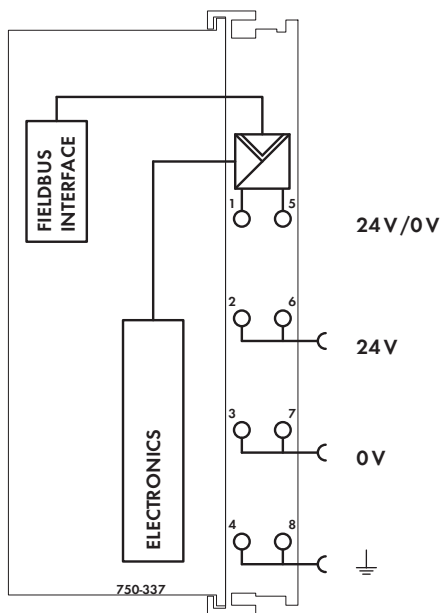

Technical Data	
Number of I/O modules	64
Max. input process image	512 bytes
Max. output process image	512 bytes
Configuration	via PC or PLC
No. of PDOs	32 Tx / 32 Rx
No. of SDOs	2 server SDOs
Communication profile	DS-301 V4.1
Device profile	DS 401 V2.0
	Marginal check
	Edge-triggered PDOs
	Programmable error response
COB ID distribution	SDO, standard
Node ID distribution	DIP switches
Other CANopen features	NMT slave
	Minimum boot-up
	Variable PDO mapping
	Emergency message
	Life guarding
	Configuration of virtual modules
Power supply	24 V DC (-25 % ... +30 %)
Max. input current (24 V)	500 mA
Power supply efficiency	87 %
Internal current consumption (5 V)	350 mA
Total current for I/O modules (5 V)	1650 mA
Isolation	500 V system/supply
Voltage via power jumper contacts	24 V DC (-25 % ... +30 %)
Current via power jumper contacts (max.)	10 A DC

General Specifications	
Operating temperature	0 °C ... +55 °C
Wire connection	CAGE CLAMP®
Cross sections	0.08 mm ² ... 2.5 mm ² / AWG 28 ... 14
Strip lengths	8 ... 9 mm / 0.33 in
Dimensions (mm) W x H x L	51 x 65 x 100
	Height from upper-edge of DIN 35 rail
Weight	220 g
Storage temperature	-25 °C ... +85 °C
Relative air humidity (no condensation)	95 %
Vibration resistance	acc. to IEC 60068-2-6
Shock resistance	acc. to IEC 60068-2-27
Degree of protection	IP20
EMC immunity of interference	acc. to EN 61000-6-2, marine applications
EMC emission of interference	acc. to EN 61000-6-4, marine applications

4 CANopen Fieldbus Coupler D-Sub

10 Kbaud ... 1 Mbaud; digital and analog signals



Fieldbus connection D-Sub

DIP switch for node ID and baud rate

Configuration interface

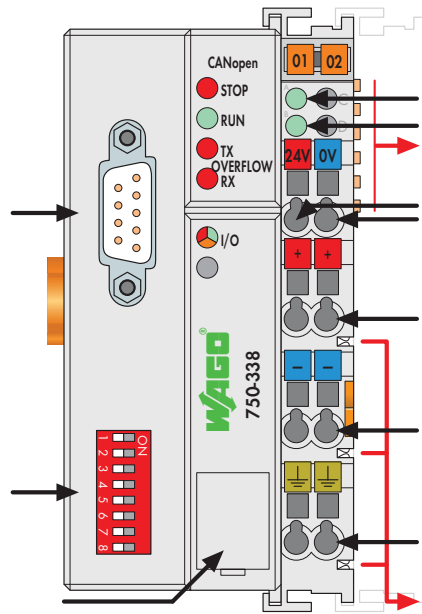

Status voltage supply
-System
-Power jumper contacts
Data contacts

Supply
24 V
0 V

Supply via power jumper contacts
24 V

0 V

⊥

Power jumper contacts

This buscoupler connects the WAGO I/O SYSTEM as a slave to the CANopen fieldbus.

The module data is transmitted using PDOs and SDOs.

The buscoupler is capable of supporting all bus modules. The buscoupler automatically configures, creating a local process image which may include analog, digital or specialty modules. Analog and specialty module data is sent via words and/or bytes, digital data is packed into bytes. CANopen allows the storing of the process image in the corresponding Master control (PLC, PC or NC).

The local process image is divided into two data zones containing the data received and the data to be sent.

Notice: EDS files required

The process data can be sent via the CANopen fieldbus to the PLC, PC or NC for further processing, and received from the field via CANopen.

The data of the analog modules is stored in the PDOs according to the order in which the modules are connected to the buscoupler. The bits of the digital modules are sent byte by byte and also mapped in the PDOs. If the amount of digital information exceeds 8 bits, the buscoupler automatically starts with a new byte.

All entries of the object dictionary can be mapped - as the user likes - in the 32 Rx PDOs and 32 Tx PDOs.

The complete input and output process image can be transmitted using SDOs. "Spacer modules" can be set via software.

Description	Item No.	Pack. Unit
CANopen D-Sub	750-338	1
Accessories		
EDS files Download: www.wago.com		
Miniature WSB Quick marking system		
	plain 248-501	5
	with marking see Section 11	
Approvals		
Conformity marking	CE	
Korea Certification	KC	
Marine applications	BV, GL, NKK, PRS, RINA	
UL 508	UL 508	
ANSI/ISA 12.12.01	Class I, Div. 2, Grp. ABCD, T4	
TÜV 07 ATEX 554086 X	I M2 Ex d I Mb, II 3 G Ex nA IIC T4 Gc, II 3 D Ex tc IIIC T135°C Dc	
Permissible ambient temperature	0 °C ... +60 °C	
IECEx TUN 09.0001 X	Ex d I Mb, Ex nA IIC T4 Gc, Ex tc IIIC T135°C Dc	
Permissible ambient temperature	0 °C ... +60 °C	

System Data	
No. of couplers connected to Master	110
Transmission medium	Shielded Cu cable 3 x 0.25 mm ²
Max. length of bus line	30 m ... 1000 m (depends on baud rate/cable)
Baud rate	10 Kbaud ... 1 Mbaud
Buscoupler connection	1 x D-Sub 9; plug

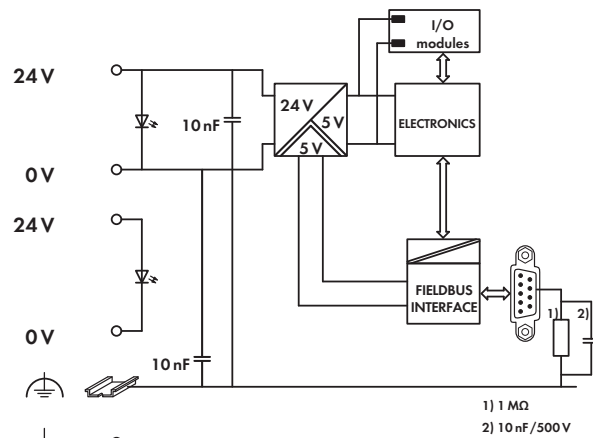
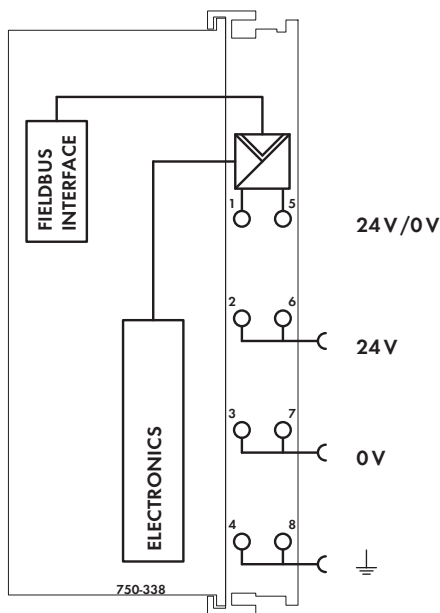

Technical Data	
Number of I/O modules	64
Max. input process image	512 bytes
Max. output process image	512 bytes
Configuration	via PC or PLC
No. of PDOs	32 Tx / 32 Rx
No. of SDOs	2 server SDOs
Communication profile	DS-301 V4.1
Device profile	DS 401 V2.0
	Marginal check
	Edge-triggered PDOs
	Programmable error response
COB ID distribution	SDO, standard
Node ID distribution	DIP switches
Other CANopen features	NMT slave
	Minimum boot-up
	Variable PDO mapping
	Emergency message
	Life guarding
	Configuration of virtual modules
Power supply	24 V DC (-25 % ... +30 %)
Max. input current (24 V)	500 mA
Power supply efficiency	87 %
Internal current consumption (5 V)	350 mA
Total current for I/O modules (5 V)	1650 mA
Isolation	500 V system/supply
Voltage via power jumper contacts	24 V DC (-25 % ... +30 %)
Current via power jumper contacts (max.)	10 A DC

General Specifications	
Operating temperature	0 °C ... +55 °C
Wire connection	CAGE CLAMP®
Cross sections	0.08 mm ² ... 2.5 mm ² / AWG 28 ... 14
Strip lengths	8 ... 9 mm / 0.33 in
Dimensions (mm) W x H x L	51 x 65 x 100
	Height from upper-edge of DIN 35 rail
Weight	200 g
Storage temperature	-25 °C ... +85 °C
Relative air humidity (no condensation)	95 %
Vibration resistance	acc. to IEC 60068-2-6
Shock resistance	acc. to IEC 60068-2-27
Degree of protection	IP20
EMC immunity of interference	acc. to EN 61000-6-2, marine applications
EMC emission of interference	acc. to EN 61000-6-4, marine applications

4 CANopen ECO Fieldbus Coupler MCS

162 10 Kbaud ... 1 Mbaud; digital and analog signals



DIP switch for node ID and baud rate

Fieldbus connection 231 Series (MCS)

Supply 24 V 0 V

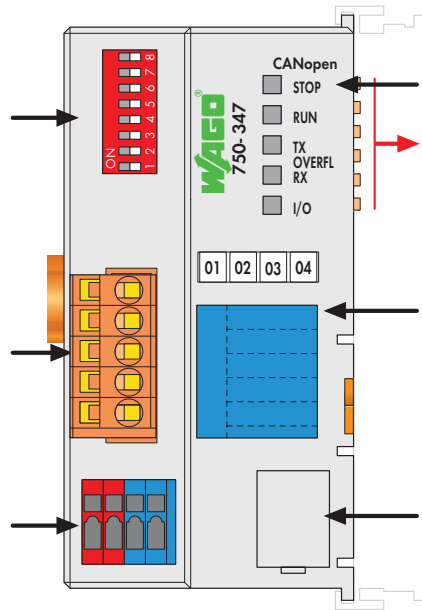

Status indication -Fieldbus -Fieldbus note

Data contacts

Marking area

Configuration interface





The ECO fieldbus coupler is designed for applications with a reduced scale I/O requirement. Using digital only process data or small amounts of analogs, while retaining all of the choice that's offered by the Series 750 I/O. The coupler has an integrated supply terminal for the system voltage. The field power jumper contacts are supplied via a separate supply module. The CANopen bus coupler is capable of supporting all I/O modules and automatically configures, creating a local process image. The local process image is divided into two data zones containing the data received and the data to be sent. The process data can be sent via the CANopen fieldbus to the PLC, PC or NC for further processing, and received from the field via CANopen.

The data of the analog modules is stored in the PDOs according to the order in which the modules are connected to the buscoupler. The bits of the digital modules are sent byte by byte and also mapped in the PDOs. If the amount of digital information exceeds 8 bits, the buscoupler automatically starts with a new byte.

All entries of the object dictionary can be mapped - as the user likes - in the 5 Rx PDOs and 5 Tx PDOs.

The complete input and output process image can be transmitted using SDOs. "Spacer modules" can be set via software.

Notice: EDS files required

Description	Item No.	Pack. Unit
CANopen ECO MCS	750-347	1
Accessories		
EDS files Download: www.wago.com		
Miniature WSB Quick marking system		
	plain 248-501	5
	with marking see Section 11	
Approvals		
Conformity marking	CE	
Korea Certification		
Marine applications	ABS, BV, DNV, GL, KR, LR, NKK, PRS, RINA	
 UL 508		
 ANSI/ISA 12.12.01	Class I, Div. 2, Grp. ABCD, T4	
TÜV 12.1297 X (Brasilien)	Ex nA IIC T4 Gc	
 TÜV 07 ATEX 554086 X	I M2 Ex d I Mb, II 3 G Ex nA IIC T4 Gc, II 3 D Ex tc IIIC T135°C Dc	
Permissible ambient temperature 0 °C ... +60 °C		
IECEx TUN 09.0001 X	Ex d I Mb, Ex nA IIC T4 Gc, Ex tc IIIC T135°C Dc	
Permissible ambient temperature 0 °C ... +60 °C		

System Data	
No. of couplers connected to Master	110
Transmission medium	Shielded Cu cable 3 x 0.25 mm ²
Max. length of bus line	30 m ... 1000 m (depends on baud rate/cable)
Baud rate	10 Kbaud ... 1 Mbaud
Buscoupler connection	5-pole male connector, 231 Series (MCS), female connector 231-305/ 010-000 (included)

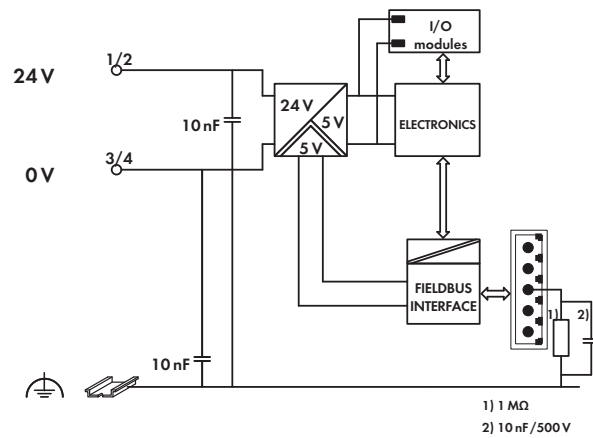
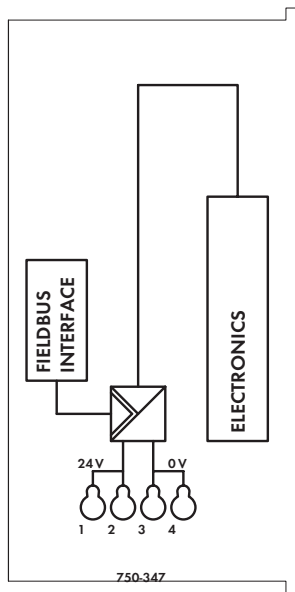

Technical Data	
Number of I/O modules	64
Max. input process image	32 bytes
Max. output process image	32 bytes
Configuration	via PC or PLC
No. of PDOs	5 Tx / 5 Rx
No. of SDOs	1 server SDO
Communication profile	DS-301 V4.1
Device profile	DS-401 V2.0
	Programmable error response
COB ID distribution	SDO, standard
Node ID distribution	DIP switches
Other CANopen features	NMT slave
	Minimum boot-up
	Variable PDO mapping
	Emergency message
	Life guarding
Power supply	24 VDC (-25 % ... +30 %)
Input current typ. at rated load (24 V)	260 mA
Efficiency of the power supply (typ.) at nominal load (24 V)	80 %
Internal current consumption (5 V)	350 mA
Total current for I/O modules (5 V)	650 mA

General Specifications	
Operating temperature	0 °C ... +55 °C
Wire connection	CAGE CLAMP®
Cross sections	0.08 mm ² ... 1.5 mm ² / AWG 28 ... 16
Strip lengths	5 ... 6 mm / 0.22 in
Dimensions (mm) W x H x L	50 x 65 x 97
	Height from upper-edge of DIN 35 rail
Weight	135 g
Storage temperature	-25 °C ... +85 °C
Relative air humidity (no condensation)	95 %
Vibration resistance	acc. to IEC 60068-2-6
Shock resistance	acc. to IEC 60068-2-27
Degree of protection	IP20
EMC immunity of interference	acc. to EN 61000-6-2, marine applications
EMC emission of interference	acc. to EN 61000-6-4, marine applications

4 CANopen ECO Fieldbus Coupler D-Sub

10 Kbaud ... 1 Mbaud; digital and analog signals



DIP switch for node ID and baud rate

Fieldbus connection D-Sub

Supply 24 V 0 V

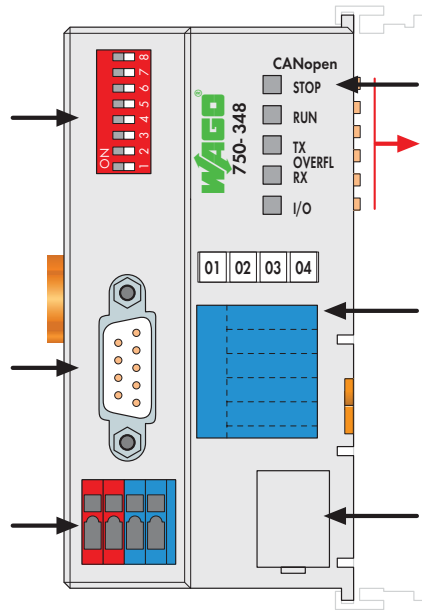

Status indication -Fieldbus -Fieldbus note

Data contacts

Marking area

Configuration interface



The ECO fieldbus coupler is designed for applications with a reduced scale I/O requirement. Using digital only process data or small amounts of analogs, while retaining all of the choice that's offered by the Series 750 I/O. The coupler has an integrated supply terminal for the system voltage. The field power jumper contacts are supplied via a separate supply module. The CANopen bus coupler is capable of supporting all I/O modules and automatically configures, creating a local process image. The local process image is divided into two data zones containing the data received and the data to be sent. The process data can be sent via the CANopen fieldbus to the PLC, PC or NC for further processing, and received from the field via CANopen.

The data of the analog modules is stored in the PDOs according to the order in which the modules are connected to the buscoupler. The bits of the digital modules are sent byte by byte and also mapped in the PDOs. If the amount of digital information exceeds 8 bits, the buscoupler automatically starts with a new byte.

All entries of the object dictionary can be mapped - as the user likes - in the 5 Rx PDOs and 5 Tx PDOs.

The complete input and output process image can be transmitted using SDOs. "Spacer modules" can be set via software.

Notice: EDS files required

Description	Item No.	Pack. Unit
CANopen ECO D-Sub	750-348	1
Accessories		
EDS files Download: www.wago.com		
Miniature WSB Quick marking system		
	plain 248-501	5
	with marking see Section 11	
Approvals		
Conformity marking	CE	
Korea Certification		
Marine applications	ABS, BV, DNV, GL, KR, LR, NKK, PRS, RINA	
UL 508	Class I, Div. 2, Grp. ABCD, T4	
ANSI/ISA 12.12.01	Class I, Div. 2, Grp. ABCD, T4	
TÜV 12.1297 X (Brasilien)	Ex nA IIC T4 Gc	
TÜV 07 ATEX 554086 X	I M2 Ex d I Mb, II 3 G Ex nA IIC T4 Gc, II 3 D Ex tc IIIC T135°C Dc	
Permissible ambient temperature	0 °C ... +60 °C	
IECEx TUN 09.0001 X	Ex d I Mb, Ex nA IIC T4 Gc, Ex tc IIIC T135°C Dc	
Permissible ambient temperature	0 °C ... +60 °C	

System Data	
No. of couplers connected to Master	110
Transmission medium	Shielded Cu cable 3 x 0.25 mm ²
Max. length of bus line	30 m ... 1000 m (depends on baud rate/cable)
Baud rate	10 Kbaud ... 1 Mbaud
Buscoupler connection	1 x D-Sub 9; plug

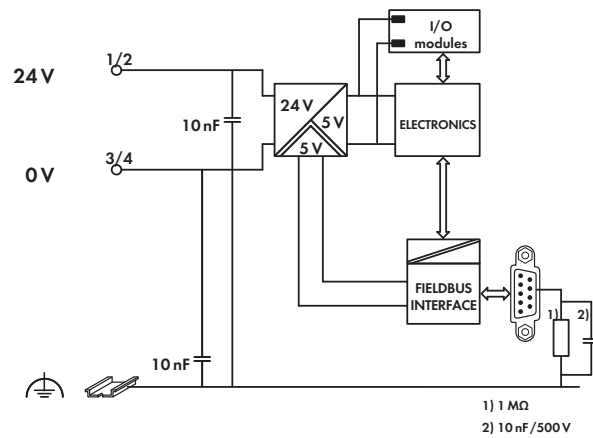
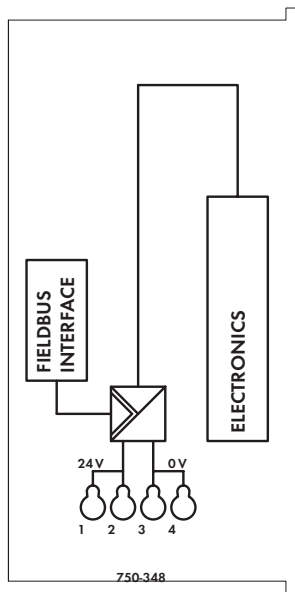

Technical Data	
Number of I/O modules	64
Max. input process image	32 bytes
Max. output process image	32 bytes
Configuration	via PC or PLC
No. of PDOs	5 Tx / 5 Rx
No. of SDOs	1 server SDO
Communication profile	DS-301 V4.1
Device profile	DS-401 V2.0
	Programmable error response
COB ID distribution	SDO, standard
Node ID distribution	DIP switches
Other CANopen features	NMT slave
	Minimum boot-up
	Variable PDO mapping
	Emergency message
	Life guarding
Power supply	24 V DC (-25 % ... +30 %)
Input current typ. at rated load (24 V)	260 mA
Efficiency of the power supply (typ.) at nominal load (24 V)	80 %
Internal current consumption (5 V)	350 mA
Total current for I/O modules (5 V)	650 mA

General Specifications	
Operating temperature	0 °C ... +55 °C
Wire connection	CAGE CLAMP®
Cross sections	0.08 mm ² ... 1.5 mm ² / AWG 28 ... 16
Strip lengths	5 ... 6 mm / 0.22 in
Dimensions (mm) W x H x L	50 x 65 x 97
	Height from upper-edge of DIN 35 rail
Weight	115 g
Storage temperature	-25 °C ... +85 °C
Relative air humidity (no condensation)	95 %
Vibration resistance	acc. to IEC 60068-2-6
Shock resistance	acc. to IEC 60068-2-27
Degree of protection	IP20
EMC immunity of interference	acc. to EN 61000-6-2, marine applications
EMC emission of interference	acc. to EN 61000-6-4, marine applications

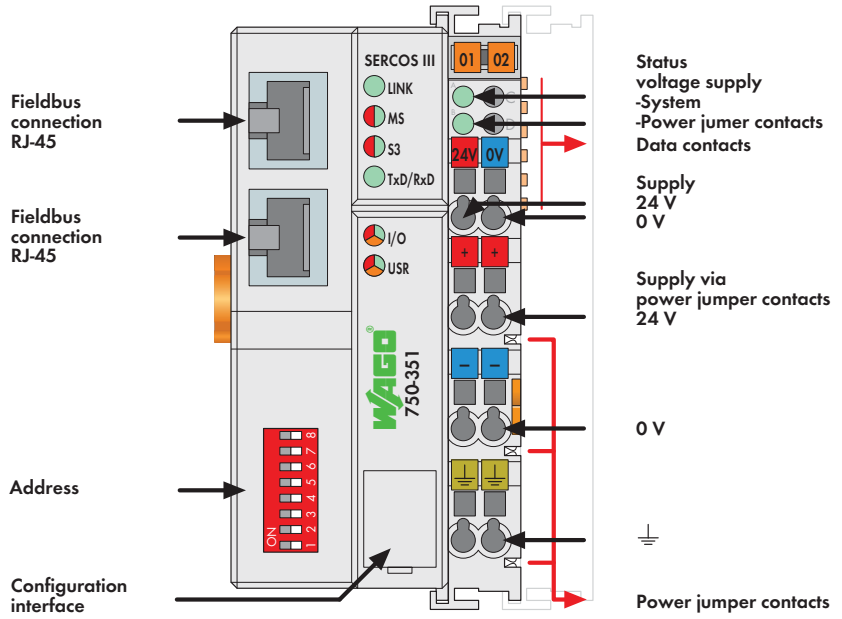

SERCOS Fieldbus Coupler

2-port; 100 Mbit/s; digital and analog signals



The 750-351 Fieldbus Coupler connects the WAGO I/O-SYSTEM to the SERCOS network. The fieldbus coupler is capable of supporting all WAGO I/O modules. The buscoupler automatically configures, creating a local process image which may include analog, digital or specialty modules. Analog and specialty module data is sent via words and/or bytes; digital data is sent bit by bit. The buscoupler can integrate into the application as a SERCOS I/O device and supports the SERCOS service channel (SVC), real-time channel (RTC) and TCP/IP communication standard.

Two integrated ports allow easy creation of a line or ring structure without requiring additional components. The ports support Auto-MDI/MDIX and will automatically detect the data direction so interchanging cables on the coupler will not impact operation. The SERCOS node ID is assigned directly via network configuration.

Description	Item No.	Pack. Unit
SERCOS Coupler	750-351	1
Accessories		
Miniature WSB Quick marking system		
	plain	248-501
	with marking	see Section 11
Approvals		
SERCOS version	V1.1.1	
IO profile	V1.1.1	
Conformity marking	CE	
Korea Certification		
Marine applications	ABS, BV, DNV, GL, KR, LR, PRS, RINA	
UL 508		
ANSI/ISA 12.12.01	Class I, Div. 2, Grp. ABCD, T4	
TÜV 07 ATEX 554086 X	I M2 Ex d I Mb, II 3 G Ex nA IIC T4 Gc, II 3 D Ex tc IIIC T135°C Dc	
Permissible ambient temperature	0 °C ... +60 °C	
IECEx TUN 09.0001 X	Ex d I Mb, Ex nA IIC T4 Gc, Ex tc IIIC T135°C Dc	
Permissible ambient temperature	0 °C ... +60 °C	

System Data	
Number of couplers (slaves) in Sercos ring	512
Transmission medium	Twisted Pair S-UTP 100 Ω Cat. 5
Max. length of fieldbus segment	100 m, limited by ETHERNET specification
Max. length of network	51.2 km, limited by ETHERNET specification
Baud rate	100 Mbit/s, full duplex
Buscoupler connection	2 x RJ-45
Protocols	SERCOS, FSP-IO, TCP/IP, FTP, HTTP, BootP, DHCP, SNTP
Supported services	SVC, RTC, CC, IP, ring break (GDP_Basic, SCP_VarCFG, SCP_Sync)

4 MODBUS Fieldbus Coupler

RS-485; 150 baud ... 115.2 Kbaud; digital and analog signals



Fieldbus connection D-Sub

Address

Address

Configuration interface

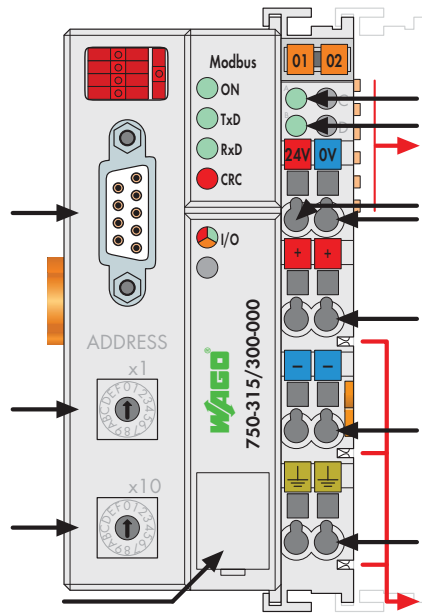

Status voltage supply -System -Power jumper contacts

Data contacts

Supply 24 V 0 V

Supply via power jumper contacts 24 V

0 V

⊥

Power jumper contacts

This buscoupler connects the WAGO-I/O-SYSTEM as a slave to the MODBUS fieldbus.

The buscoupler automatically configures, creating a local process image which may include analog, digital or specialty modules. Analog and specialty module data is sent via words and/or bytes, digital data is sent bit by bit.

The data of the analog modules is stored in the process image, which is created automatically according to the order in which the modules are connected to the buscoupler. The bits of the digital modules are sent byte by byte and added to the analog data. If the amount of digital information exceeds 8 bits, the buscoupler automatically starts with a new byte.

Description	Item No.	Pack. Unit
MODBUS / RS-485 / 150 Bd ... 115.2 kBd	750-315/300-000	1
Accessories		
Miniature WSB Quick marking system		
 plain	248-501	5
with marking	see Section 11	
Approvals		
Conformity marking	CE	
Marine applications	BV, DNV, GL, KR, NKK, PRS, RINA	
UL 508		
ANSI/ISA 12.12.01	Class I, Div. 2, Grp. ABCD, T4	
TÜV 07 ATEX 554086 X	I M2 Ex d I Mb, II 3 G Ex nA IIC T4 Gc, II 3 D Ex tc IIIC T135°C Dc	
Permissible ambient temperature	0 °C ... +60 °C	
IECEx TUN 09.0001 X	Ex d I Mb, Ex nA IIC T4 Gc, Ex tc IIIC T135°C Dc	
Permissible ambient temperature	0 °C ... +60 °C	

System Data	
No. of couplers connected to Master	247 with repeater
Max. no. of I/O points	approx. 6000 (depends on master)
Transmission medium	Shielded Cu cable 2 (4) x 0.25 mm ²
Max. length of fieldbus segment	1200 m (depends on baud rate/cable)
Baud rate	150 baud ... 115.2 Kbaud
Buscoupler connection	1 x D-Sub 9; socket

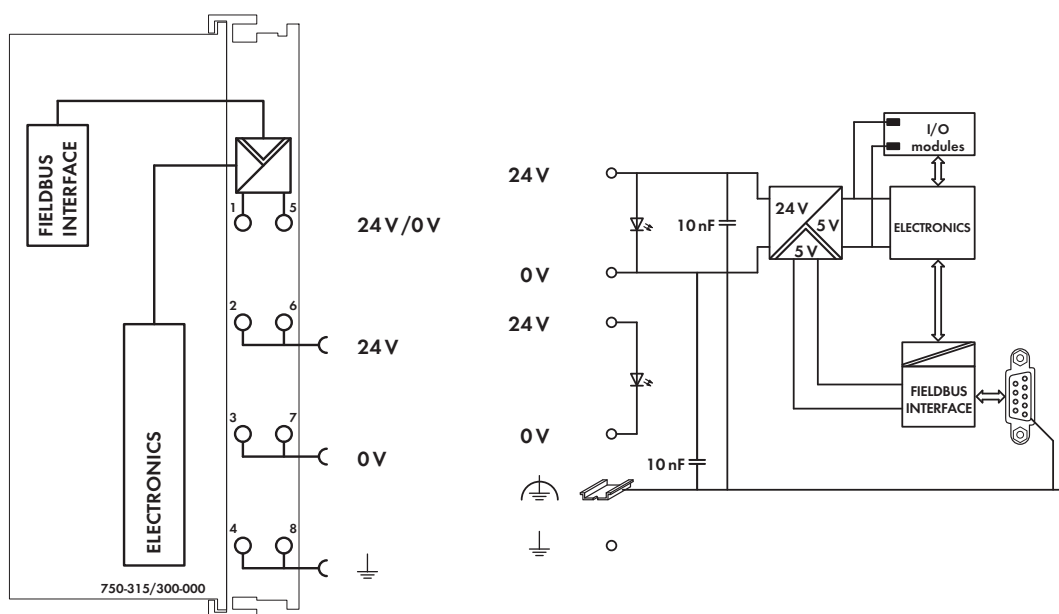

Technical Data

Number of I/O modules	64
Max. input process image	512 bytes
Max. output process image	512 bytes
Configuration	Via PC or rotary encoder switch
Power supply	24 V DC (-25 % ... +30 %)
Max. input current (24 V)	500 mA
Power supply efficiency	87 %
Internal current consumption (5 V)	350 mA
Total current for I/O modules (5 V)	1650 mA
Isolation	500 V system/supply
Voltage via power jumper contacts	24 V DC (-25 % ... +30 %)
Current via power jumper contacts (max.)	10 A DC

General Specifications

Operating temperature	0 °C ... +55 °C
Wire connection	CAGE CLAMP®
Cross sections	0.08 mm ² ... 2.5 mm ² / AWG 28 ... 14
Strip lengths	8 ... 9 mm / 0.33 in
Dimensions (mm) W x H x L	51 x 65 x 100
	Height from upper-edge of DIN 35 rail
Weight	183.2 g
Storage temperature	-25 °C ... +85 °C
Relative air humidity (no condensation)	95 %
Vibration resistance	acc. to IEC 60068-2-6
Shock resistance	acc. to IEC 60068-2-27
Degree of protection	IP20
EMC immunity of interference	acc. to EN 61000-6-2, marine applications
EMC emission of interference	acc. to EN 61000-6-4, marine applications

4 MODBUS Fieldbus Coupler

RS-232; 150 baud ... 115.2 Kbaud; digital and analog signals



Fieldbus connection D-Sub

Address

Address

Configuration interface

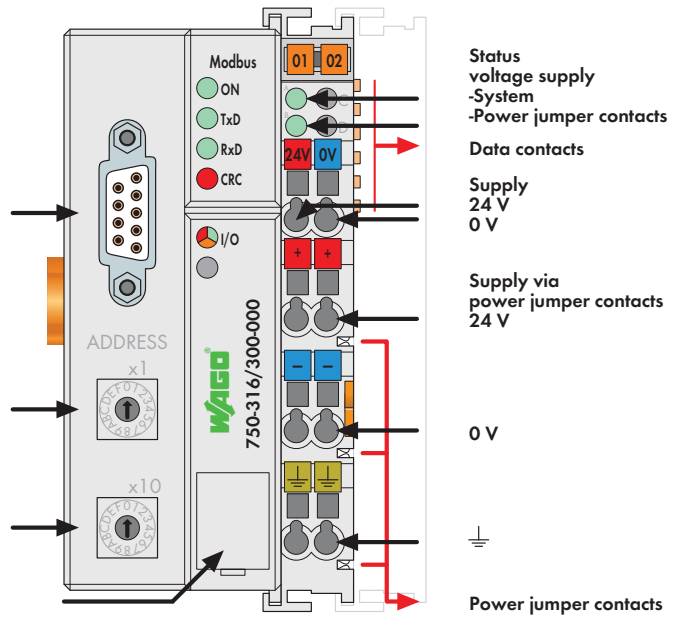

This buscoupler connects the WAGO-I/O-SYSTEM as a slave to the MODBUS fieldbus.

The buscoupler automatically configures, creating a local process image which may include analog, digital or specialty modules. Analog and specialty module data is sent via words and/or bytes, digital data is sent bit by bit.

The data of the analog modules is stored in the process image, which is created automatically according to the order in which the modules are connected to the buscoupler. The bits of the digital modules are sent byte by byte and added to the analog data. If the amount of digital information exceeds eight bits, the buscoupler automatically starts with a new byte.

Description	Item No.	Pack. Unit
MODBUS / RS-232 / 150 Bd ... 115.2 kBd	750-316/300-000	1
Accessories		
Miniature WSB Quick marking system		
 plain	248-501	5
with marking	see Section 11	
Approvals		
Conformity marking	CE	
Marine applications	BV, DNV, GL, KR, NKK, PRS, RINA	
UL 508		
ANSI/ISA 12.12.01	Class I, Div. 2, Grp. ABCD, T4	
TÜV 07 ATEX 554086 X	II 3 G Ex nA IIC T4 Gc, II 3 D Ex tc IIIC T135°C Dc	
Permissible ambient temperature	0 °C ... +60 °C	
IECEX TUN 09.0001 X	Ex d I Mb, Ex nA IIC T4 Gc, Ex tc IIIC T135°C Dc	
Permissible ambient temperature	0 °C ... +60 °C	

System Data	
No. of couplers connected to Master	247 with repeater
Max. no. of I/O points	approx. 6000 (depends on master)
Transmission medium	Shielded Cu cable 2 (4) x 0.25 mm ²
Max. length of fieldbus segment	1200 m (depends on baud rate/cable)
Baud rate	150 baud ... 115.2 Kbaud
Buscoupler connection	1 x D-Sub 9; socket

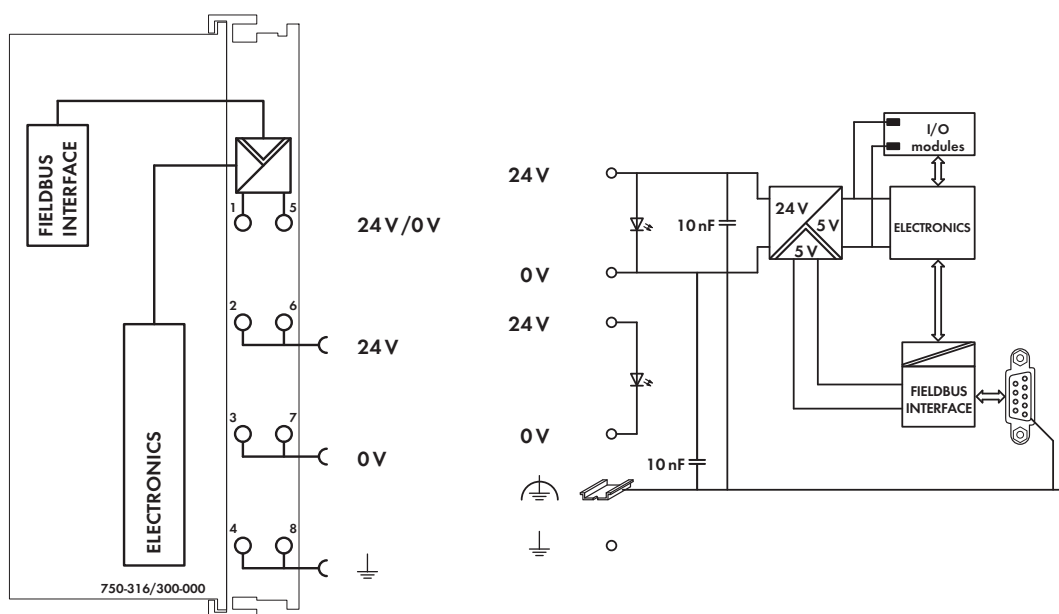

Technical Data

Number of I/O modules	64
Max. input process image	512 bytes
Max. output process image	512 bytes
Configuration	Via PC or rotary encoder switch
Power supply	24 V DC (-25 % ... +30 %)
Max. input current (24 V)	500 mA
Power supply efficiency	87 %
Internal current consumption (5 V)	350 mA
Total current for I/O modules (5 V)	1650 mA
Isolation	500 V system/supply
Voltage via power jumper contacts	24 V DC (-25 % ... +30 %)
Current via power jumper contacts (max.)	10 A DC

General Specifications

Operating temperature	0 °C ... +55 °C
Wire connection	CAGE CLAMP®
Cross sections	0.08 mm ² ... 2.5 mm ² / AWG 28 ... 14
Strip lengths	8 ... 9 mm / 0.33 in
Dimensions (mm) W x H x L	51 x 65 x 100
	Height from upper-edge of DIN 35 rail
Weight	184.8 g
Storage temperature	-25 °C ... +85 °C
Relative air humidity (no condensation)	95 %
Vibration resistance	acc. to IEC 60068-2-6
Shock resistance	acc. to IEC 60068-2-27
Degree of protection	IP20
EMC immunity of interference	acc. to EN 61000-6-2, marine applications
EMC emission of interference	acc. to EN 61000-6-4, marine applications

INTERBUS Fieldbus Coupler

500 Kbaud; digital and analog signals



Fieldbus connection D-Sub, Input

Fieldbus connection D-Sub, Output

Configuration interface

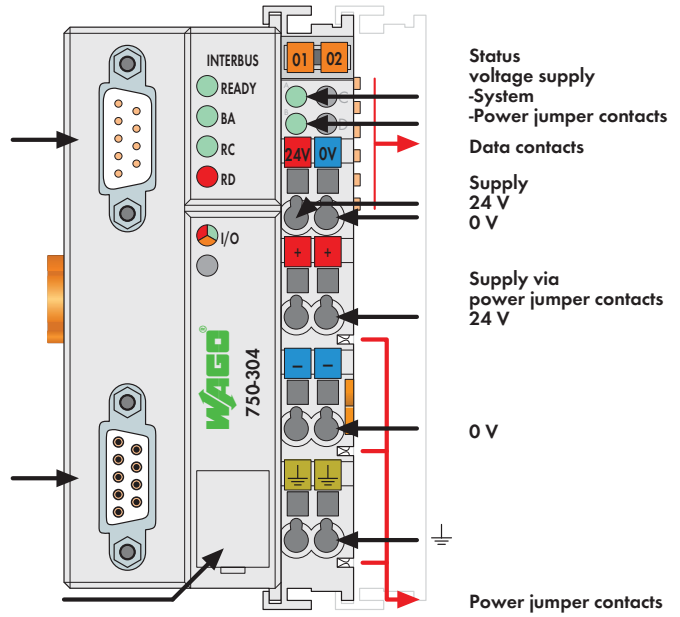



This buscoupler connects the WAGO-I/O-SYSTEM as a slave to the INTERBUS fieldbus.

The buscoupler automatically configures, creating a local process image which may include analog, digital or specialty modules. Analog and specialty module data is sent via words and/or bytes, digital data is sent bit by bit.

INTERBUS stores the process image in the corresponding Master control (PLC, PC or NC).

The local process image is divided into two data zones containing the data received and the data to be sent. The process data can be sent via the INTERBUS fieldbus to the PLC, PC or NC for further processing, and received from the field via INTERBUS. The process data can be sent via the INTERBUS fieldbus to the PLC, PC or NC for further processing, and received from the field via INTERBUS.

The data of the analog modules is stored in the process image which is created automatically according to the order in which the modules are connected to the buscoupler. The bits of the digital modules are sent byte by byte and added to the analog data. If the amount of digital information exceeds 8 bits, the buscoupler automatically starts with a new byte.

Description	Item No.	Pack. Unit
INTERBUS 500 kBd	750-304	1
Accessories		
INTERBUS files	Download: www.wago.com	
Miniature WSB Quick marking system		
 plain	248-501	5
with marking	see Section 11	
Standards and Approvals		
Standard	EN 50254	
Certification	INTERBUS CLUB	
Conformity marking	CE	
Korea Certification		
UL 508		
ANSI/ISA 12.12.01	Class I, Div. 2, Grp. ABCD, T4	
TÜV 07 ATEX 554086 X	I M2 Ex d I Mb, II 3 G Ex nA IIC T4 Gc, II 3 D Ex tc IIIC T135°C Dc	
Permissible ambient temperature 0 °C ... +60 °C		
IECEx TUN 09.0001 X	Ex d I Mb, Ex nA IIC T4 Gc, Ex tc IIIC T135°C Dc	
Permissible ambient temperature 0 °C ... +60 °C		

System Data	
No. of couplers connected to Master	256
Max. no. of I/O points	4096 (depends on master)
Transmission medium	Certified Cu cable
Max. length of fieldbus segment	400 m
Baud rate	500 Kbaud
Transmission time	typ. 1.43 ms (10 couplers; 32 digital I/Os)
Buscoupler connection	1 x D-Sub 9; plug for input interface 1 x D-Sub 9; socket for output interface

4 INTERBUS ECO Fieldbus Coupler

174 500 Kbaud; digital and analog signals



Fieldbus connection D-Sub Input

Fieldbus connection D-Sub, Output

Supply 24 V 0 V

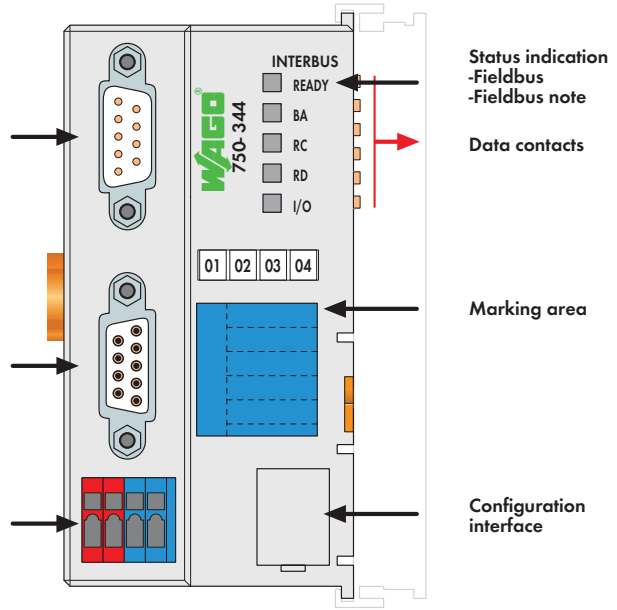

The ECO fieldbus coupler is designed for applications with a reduced scale I/O requirement. Using digital only process data or small amounts of analogs, while retaining all of the choice that's offered by the Series 750 I/O.



The coupler has an integrated supply terminal for the system voltage. The field power jumper contacts are supplied via a separate supply module.

The INTERBUS bus coupler automatically configures, creating a local process image which may include analog, digital or specialty modules.

INTERBUS stores the process image in the corresponding Master control (PLC, PC or NC).

The local process image is divided into two data zones containing the data received and the data to be sent. The process data can be sent via the INTERBUS fieldbus to the PLC, PC or NC for further processing, and received from the field via INTERBUS.

The data of the analog modules is stored in the process image which is created automatically according to the order in which the modules are connected to the buscoupler. The bits of the digital modules are sent byte by byte and added to the analog data. If the amount of digital information exceeds 8 bits, the buscoupler automatically starts with a new byte.

Description	Item No.	Pack. Unit
INTERBUS ECO 500 kbd	750-344	1
Accessories		
INTERBUS files	Download: www.wago.com	
Miniature WSB Quick marking system		
 plain	248-501	5
with marking	see Section 11	
Standards and Approvals		
Standard	EN 50254	
Conformity marking	CE	
Korea Certification		
UL 508		
ANSI/ISA 12.12.01	Class I, Div. 2, Grp. ABCD, T4	
TÜV 12.1297 X (Brasilien)	Ex nA IIC T4 Gc	
TÜV 07 ATEX 554086 X	I M2 Ex d I Mb, II 3 G Ex nA IIC T4 Gc, II 3 D Ex tc IIIC T135°C Dc	
Permissible ambient temperature	0 °C ... +60 °C	
IECEx TUN 09.0001 X	Ex d I Mb, Ex nA IIC T4 Gc, Ex tc IIIC T135°C Dc	
Permissible ambient temperature	0 °C ... +60 °C	

System Data	
No. of couplers connected to Master	256
Max. no. of I/O points	4096 (depends on master)
Transmission medium	Certified Cu cable
Max. length of fieldbus segment	400 m
Baud rate	500 Kbaud
Transmission time	typ. 1.43 ms (10 couplers; 32 digital I/Os per coupler)
Buscoupler connection	1 x D-Sub 9; plug for input interface 1 x D-Sub 9; socket for output interface

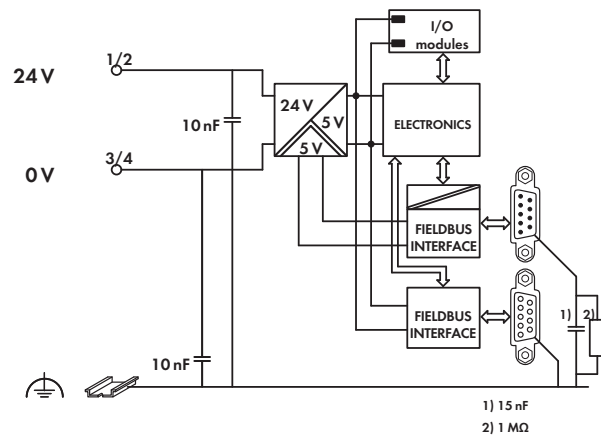
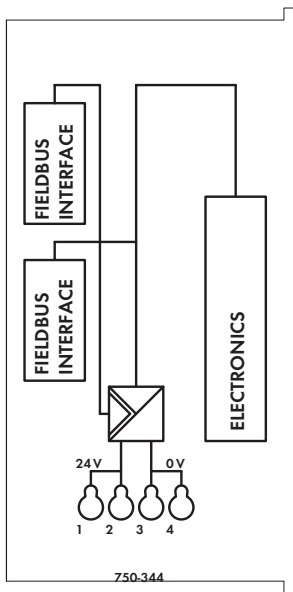
Technical Data

Number of I/O modules	64
Max. input process image	20 bytes
Max. output process image	20 bytes
Configuration	via PC or PLC
Power supply	24 V DC (-15 % ... +20 %)
Input current typ. at rated load (24 V)	260 mA
Efficiency of the power supply (typ.) at nominal load (24 V)	80 %
Internal current consumption (5 V)	350 mA
Total current for I/O modules (5 V)	650 mA

General Specifications

Operating temperature	0 °C ... +55 °C
Wire connection	CAGE CLAMP®
Cross sections	0.08 mm ² ... 1.5 mm ² / AWG 28 ... 16
Strip lengths	5 ... 6 mm / 0.22 in
Dimensions (mm) W x H x L	50 x 65 x 97
	Height from upper-edge of DIN 35 rail
Weight	115 g
Storage temperature	-25 °C ... +85 °C
Relative air humidity (no condensation)	95 %
Vibration resistance	acc. to IEC 60068-2-6
Shock resistance	acc. to IEC 60068-2-27
Degree of protection	IP20
EMC immunity of interference	acc. to EN 61000-6-2
EMC emission of interference	acc. to EN 61000-6-4

4 INTERBUS ECO Fieldbus Coupler

176 2 Mbaud; digital and analog signals



Fieldbus connection
D-Sub
Input

Fieldbus connection
D-Sub
Output

Supply
24 V
0 V

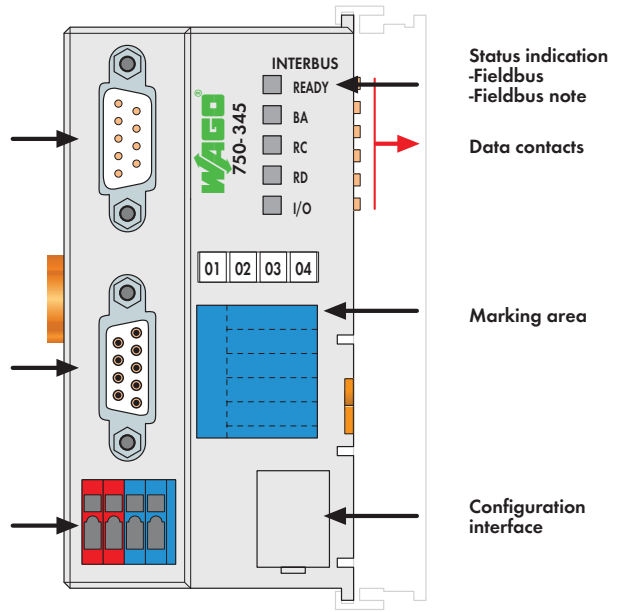



This buscoupler connects the WAGO-I/O-SYSTEM as a slave to the INTERBUS fieldbus.

The buscoupler automatically configures, creating a local process image which may include analog, digital or specialty modules. Analog and specialty module data is sent via words and/or bytes, digital data is sent bit by bit.

INTERBUS stores the process image in the corresponding Master control (PLC, PC or NC).

The local process image is divided into two data zones containing the data received and the data to be sent. The process data can be sent via the INTERBUS fieldbus to the PLC, PC or NC for further processing, and received from the field via INTERBUS.

The data of the analog modules is stored in the process image which is created automatically according to the order in which the modules are connected to the buscoupler. The bits of the digital modules are sent byte by byte and added to the analog data. If the amount of digital information exceeds 8 bits, the buscoupler automatically starts with a new byte.

Description	Item No.	Pack. Unit
INTERBUS ECO 2 MBd	750-345	1
Accessories		
INTERBUS files	Download: www.wago.com	
Miniature WSB Quick marking system		
 plain	248-501	5
with marking	see Section 11	
Standards and Approvals		
Standard	EN 50254	
Conformity marking	CE	
Korea Certification		
UL 508		
ANSI/ISA 12.12.01	Class I, Div. 2, Grp. ABCD, T4	
TÜV 12.1297 X (Brasilien)	Ex nA IIC T4 Gc	
TÜV 07 ATEX 554086 X	I M2 Ex d I Mb, II 3 G Ex nA IIC T4 Gc, II 3 D Ex tc IIIC T135°C Dc	
Permissible ambient temperature	0 °C ... +60 °C	
IECEx TUN 09.0001 X	Ex d I Mb, Ex nA IIC T4 Gc, Ex tc IIIC T135°C Dc	
Permissible ambient temperature	0 °C ... +60 °C	

System Data	
No. of couplers connected to Master	256
Max. no. of I/O points	4096 (depends on master)
Transmission medium	Certified Cu cable
Max. length of fieldbus segment	150 m
Baud rate	2 Mbaud
Transmission time	on request
Buscoupler connection	1 x D-Sub 9; plug for input interface 1 x D-Sub 9; socket for output interface

INTERBUS Fieldbus Coupler

digital and analog signals; fiber optic

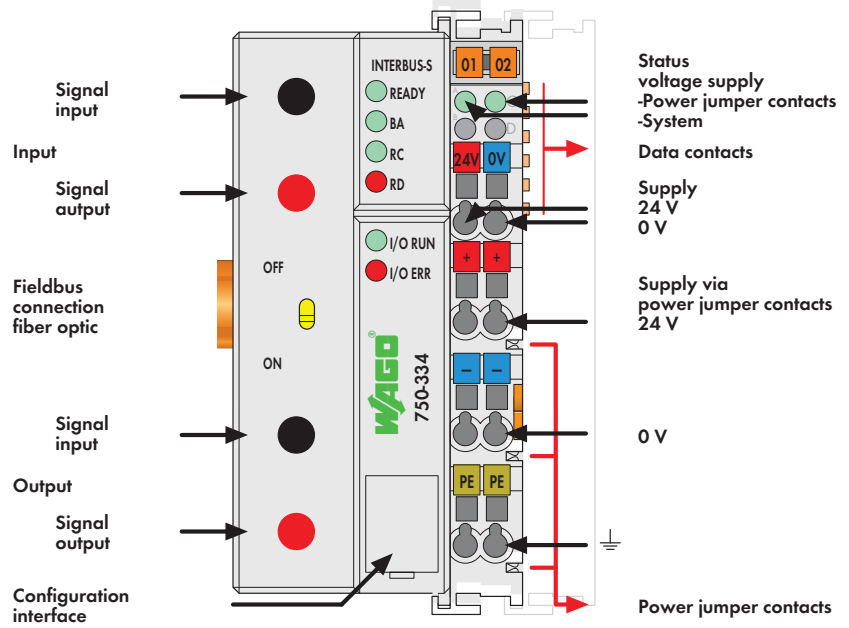

This buscoupler connects the WAGO-I/O-SYSTEM as a slave to the INTERBUS fieldbus.

The buscoupler automatically configures, creating a local process image which may include analog, digital or specialty modules. Analog and specialty module data is sent via words and/or bytes, digital data is sent bit by bit.

The local process image is divided into two data zones containing the data received and the data to be sent. The process data can be sent via the INTERBUS fieldbus to the PLC, PC or NC for further processing, and received from the field via INTERBUS.

The data of the analog modules is stored in the process image which is created automatically according to the order in which the modules are connected to the buscoupler. The bits of the digital modules are sent byte by byte and added to the analog data. If the amount of digital information exceeds 8 bits, the buscoupler automatically starts with a new byte.

The fiber optic INTERBUS coupler can be put in any place on the ring.

Description	Item No.	Pack. Unit
INTERBUS 500 kBd / Opt. Fiber	750-334	1
Accessories		
INTERBUS files	Download: www.wago.com	
Miniature WSB Quick marking system	plain	5
	with marking	see Section 11
Standards and Approvals		
Standard	EN 50254	
Certification	INTERBUS CLUB	
Conformity marking	CE	
Korea Certification	KC	
UL 508		
ANSI/ISA 12.12.01	Class I, Div. 2, Grp. ABCD, T4	
TÜV 12.1297 X (Brasilien)	Ex nA IIC T4 Gc	
DEKRA 11 ATEX 0203 X	II 3 G Ex nA II T4	

System Data	
No. of couplers connected to Master	256
Max. no. of I/O points	4096 (depends on master)
Transmission medium	APF (plastic) fiber (1000µm)
Topology	Ring, double fiber ring
Max. length of fieldbus segment	1 m ... 40 m
Baud rate	500 Kbaud
Buscoupler connection	F-SMA

4 CC-Link Fieldbus Coupler

180 156 Kbaud ... 10 Mbaud; digital and analog signals

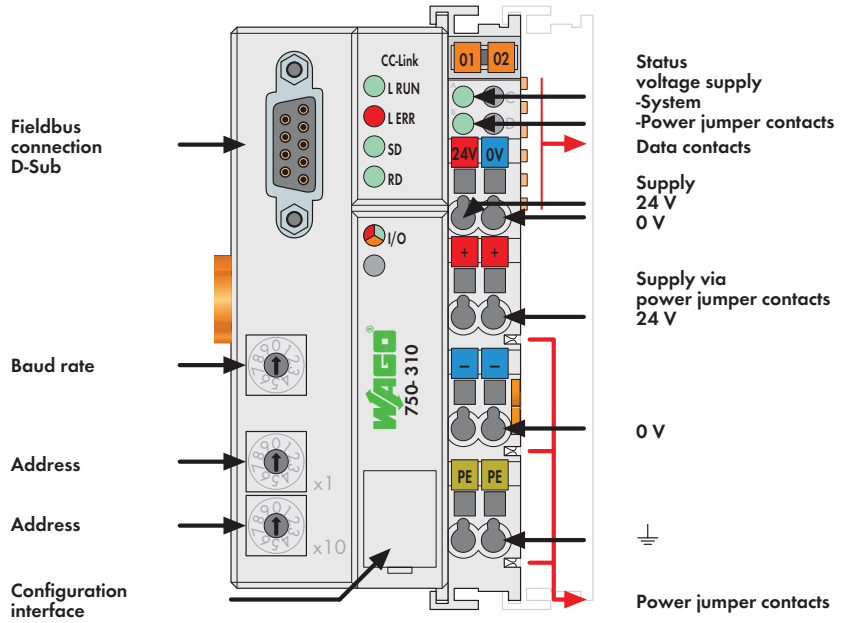



This buscoupler connects the WAGO-I/O-SYSTEM as a slave to the CC-Link fieldbus.

The buscoupler automatically configures, creating a local process image which may include analog, digital or specialty modules. Analog and specialty module data is sent via words and/or bytes, digital data is sent bit by bit.

CC-Link stores the process image in the corresponding Master control (PLC, PC or NC).

The local process image is divided into two data zones containing the data received and the data to be sent. The process data can be sent via the CC-Link fieldbus to the PLC, PC or NC for further processing, and received from the field via CC-Link.

The data of the analog modules is stored in the process image which is created automatically according to the order in which the modules are connected to the buscoupler. The bits of the digital modules are sent byte by byte and added to the analog data. If the amount of digital information exceeds 8 bits, the buscoupler automatically starts with a new byte.

Description	Item No.	Pack. Unit
CC-Link	750-310	1
Accessories		
Miniature WSB Quick marking system		
 plain	248-501	5
with marking	see Section 11	
Bus connector with D-Sub male connector; 9 poles	750-965	1
Approvals		
Conformity marking	CE	
Korea Certification		
UL 508		
ANSI/ISA 12.12.01	Class I, Div. 2, Grp. ABCD, T4	
TÜV 07 ATEX 554086 X	I M2 Ex d I Mb, II 3 G Ex nA IIC T4 Gc, II 3 D Ex tc IIIC T135°C Dc	
Permissible ambient temperature	0 °C ... +60 °C	
IECEx TUN 09.0001 X	Ex d I Mb, Ex nA IIC T4 Gc, Ex tc IIIC T135°C Dc	
Permissible ambient temperature	0 °C ... +60 °C	

System Data	
No. of couplers connected to Master	64
Transmission medium	Shielded Cu cable 2 / 3 x 0.5 mm ²
Max. length of bus line	100 m ... 1200 m (depends on baud rate/cable)
Baud rate	156 Kbaud ... 10 Mbaud
Buscoupler connection	1 x D-Sub 9; socket

